

Performance degradation of SiPM sensors under various irradiation fields and recovery via high-temperature annealing

C. Ripoli on behalf of dRICH Collaboration
Salerno University and INFN – cripoli@unisa.it

ePIC experiment

The future Electron-Ion Collider (EIC) will explore the internal structure of nucleons using deep inelastic scattering. The electron-Proton/Ion Collider (ePIC) detector is designed to provide precise tracking, calorimetry and PID capabilities. The dual-Ring Imaging Cherenkov (dRICH) is designed to provide continuous hadron identification in a broad momentum range (3 GeV/c to 50 GeV/c) and in the forward region ($1.5 < \eta < 3.5$).

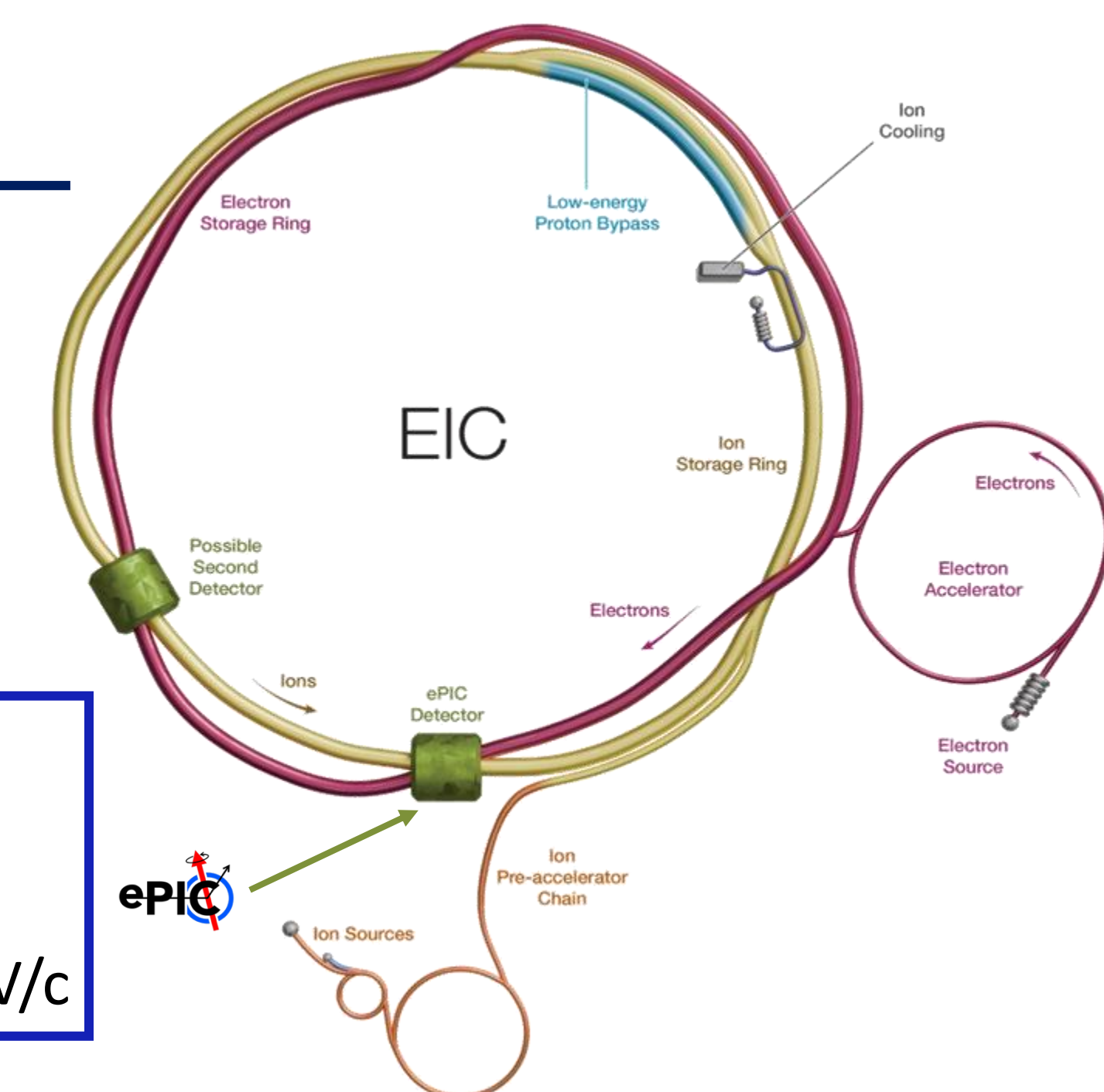

PID:
 $p = [3-50] \text{ GeV/c}$
 $\eta = [1.5-3.5]$
e-ID up to 15 GeV/c

- Radiators** → aerogel ($n \sim 1.02$) and C_2F_6 ($n \sim 1.0008$)
- Mirrors** → large outward-reflecting, 6 open sectors
- Sensors** → $3 \times 3 \text{ mm}^2$ pixel, $0.5 \text{ m}^2 / \text{sector}$
 - single-photon detection inside high B field ($\sim 1 \text{ T}$)
 - outside of acceptance, reduced constraint
 - Silicon photomultiplier (SiPM) optical readout

Layout of the ePIC barrel detector

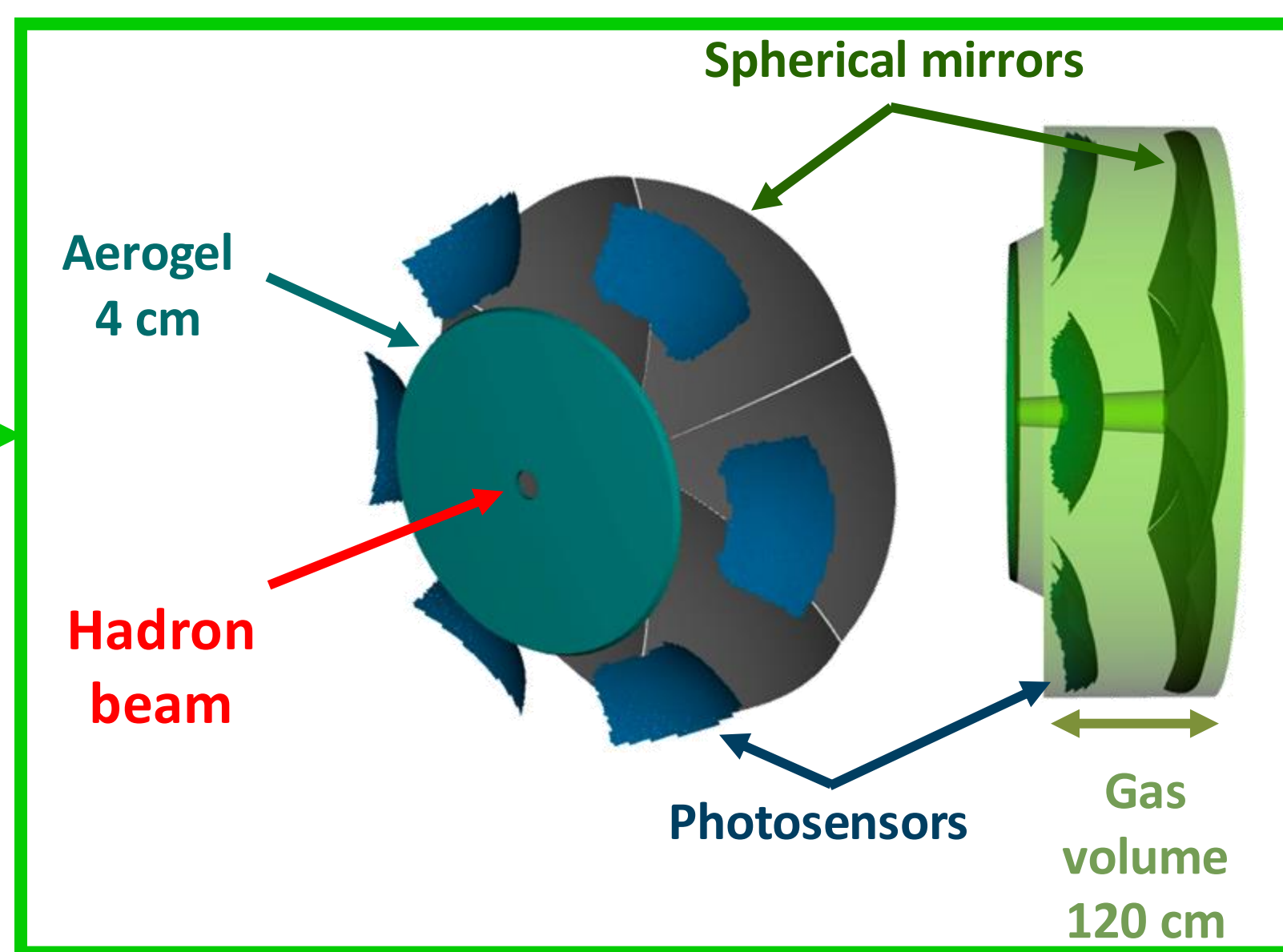
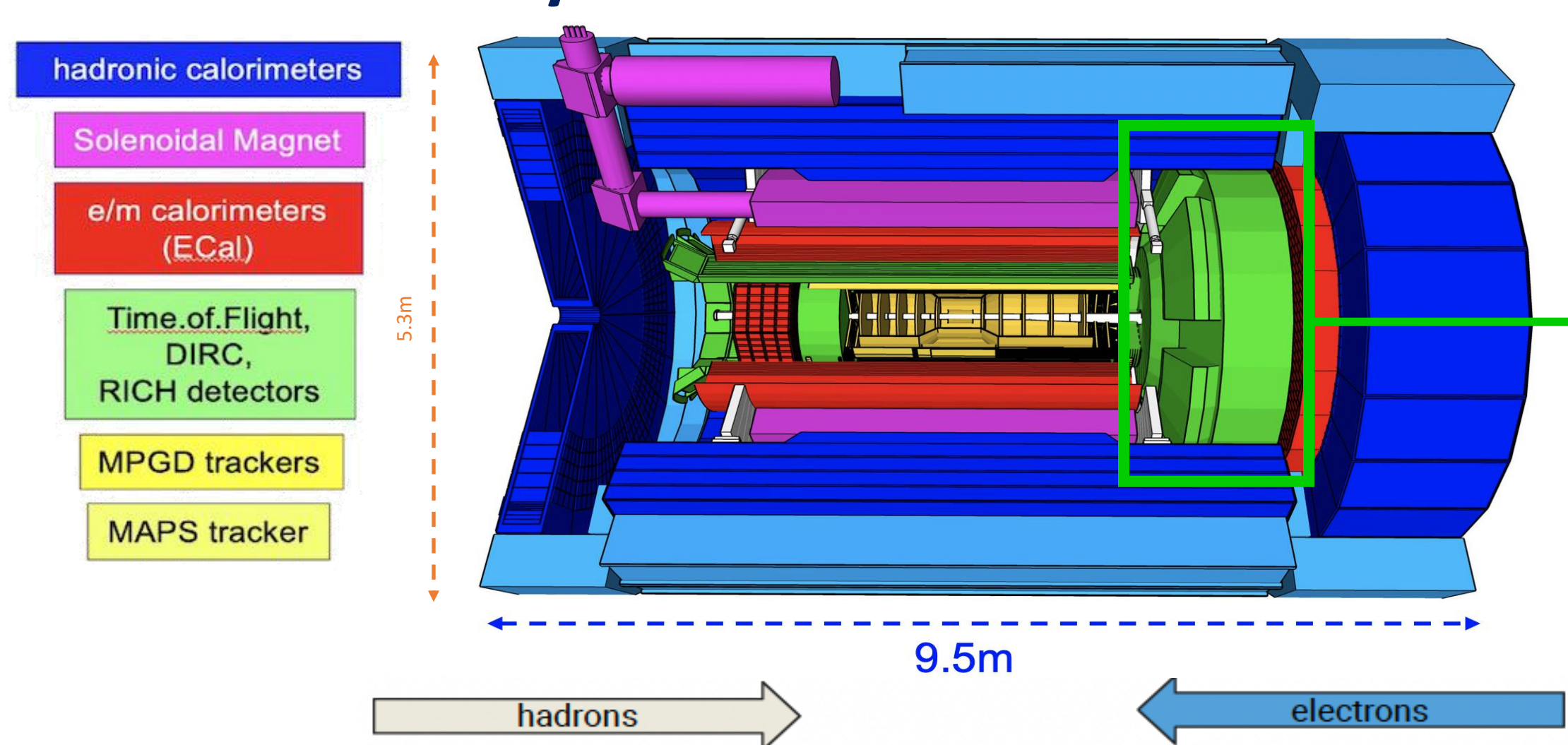

dRICH optical readout

The dRICH detector will make use of SiPM sensors for the detection of the Cherenkov light emitted by particles crossing its radiators. The photodetector will cover 3 m^2 with $(3 \times 3) \text{ mm}^2$ pixels, for a total of more than 300k readout channels.

SiPM as photo-detection units:

- Ability to detect light at the single photon level
- High photon detection efficiency
- Insensitive in high-magnetic field
- Excellent time resolution
- High sensitivity to radiation damage
- Large Dark Count Rate (DCR)



First application of SiPMs for single-photon detection in a HEP experiment

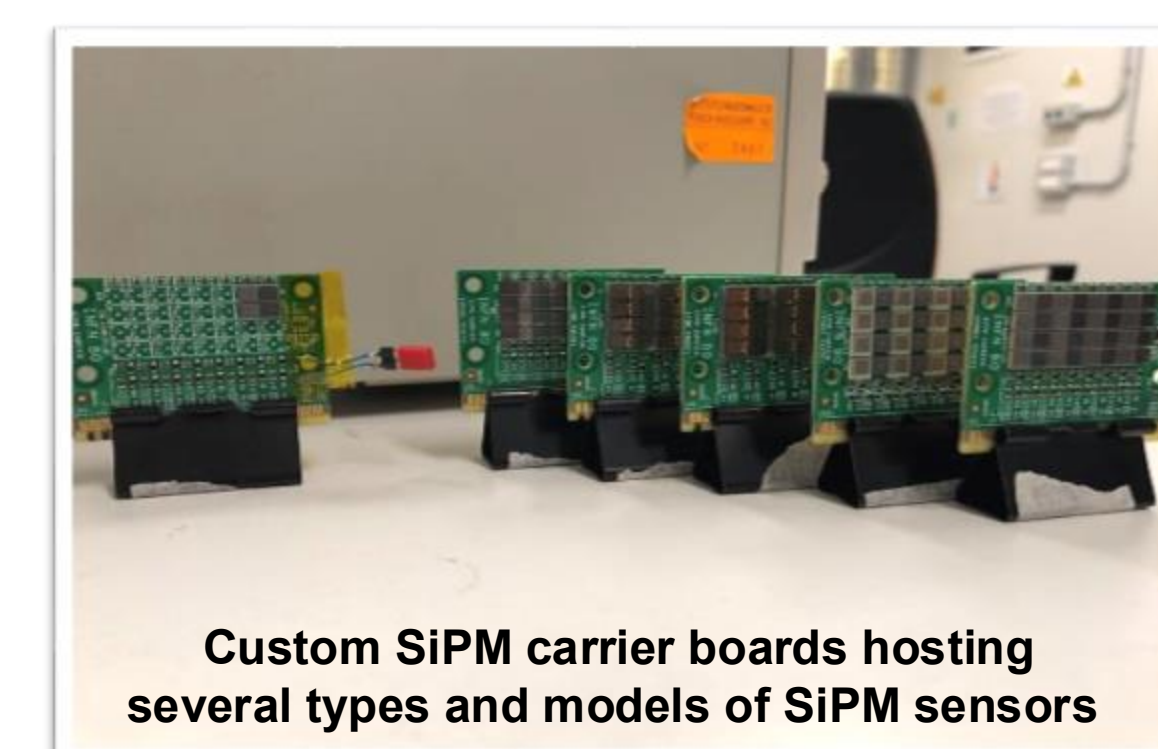

Irradiation and damage

SiPMs were subjected to fluences up to $\sim 10^{10} \text{ n}_{\text{eq}}/\text{cm}^2$ corresponding to the expected cumulative dose over a decade of EIC operation

- Proton:** Trento Proton Therapy Centre, delivering integrated fluences up to $10^{11} \text{ 1-MeV n}_{\text{eq}}/\text{cm}^2$ to the SiPMs and studying different proton energies from 18 to 138 MeV.
- Neutron:** CN accelerator of the INFN Legnaro National Laboratories at integrated fluences up to $10^{10} \text{ 1-MeV n}_{\text{eq}}/\text{cm}^2$.
- Gamma:** CERN GIF++ facility up to 1 krad.

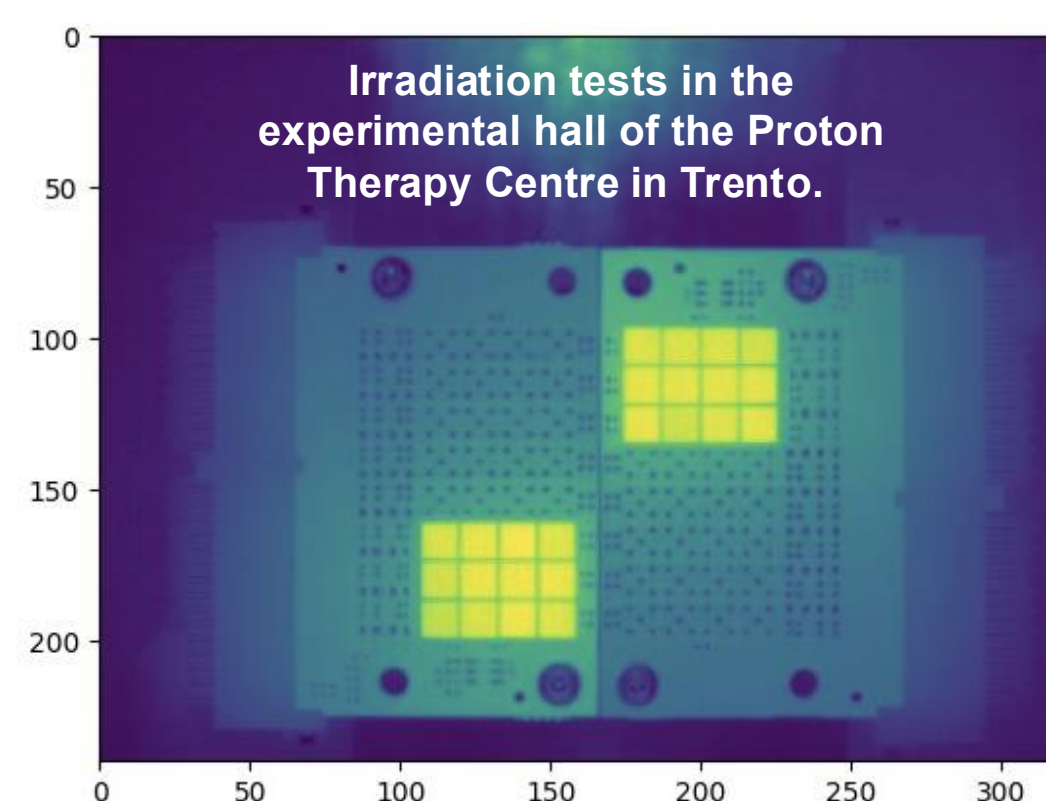

Technical solution and mitigation strategy

- Cooling** operating at low temperature (down to $-30 \text{ }^\circ\text{C}$)
- Timing** precise timing with fast TDC electronics helps to reduce the effect of DCR as background signal
- Annealing** recovery of radiation damage via high-temperature annealing cycles

Annealing and recovery studies

Oven annealing

- 160 hours up to $150 \text{ }^\circ\text{C}$
- Linear trend with dose
- A factor 100 of damage reduction

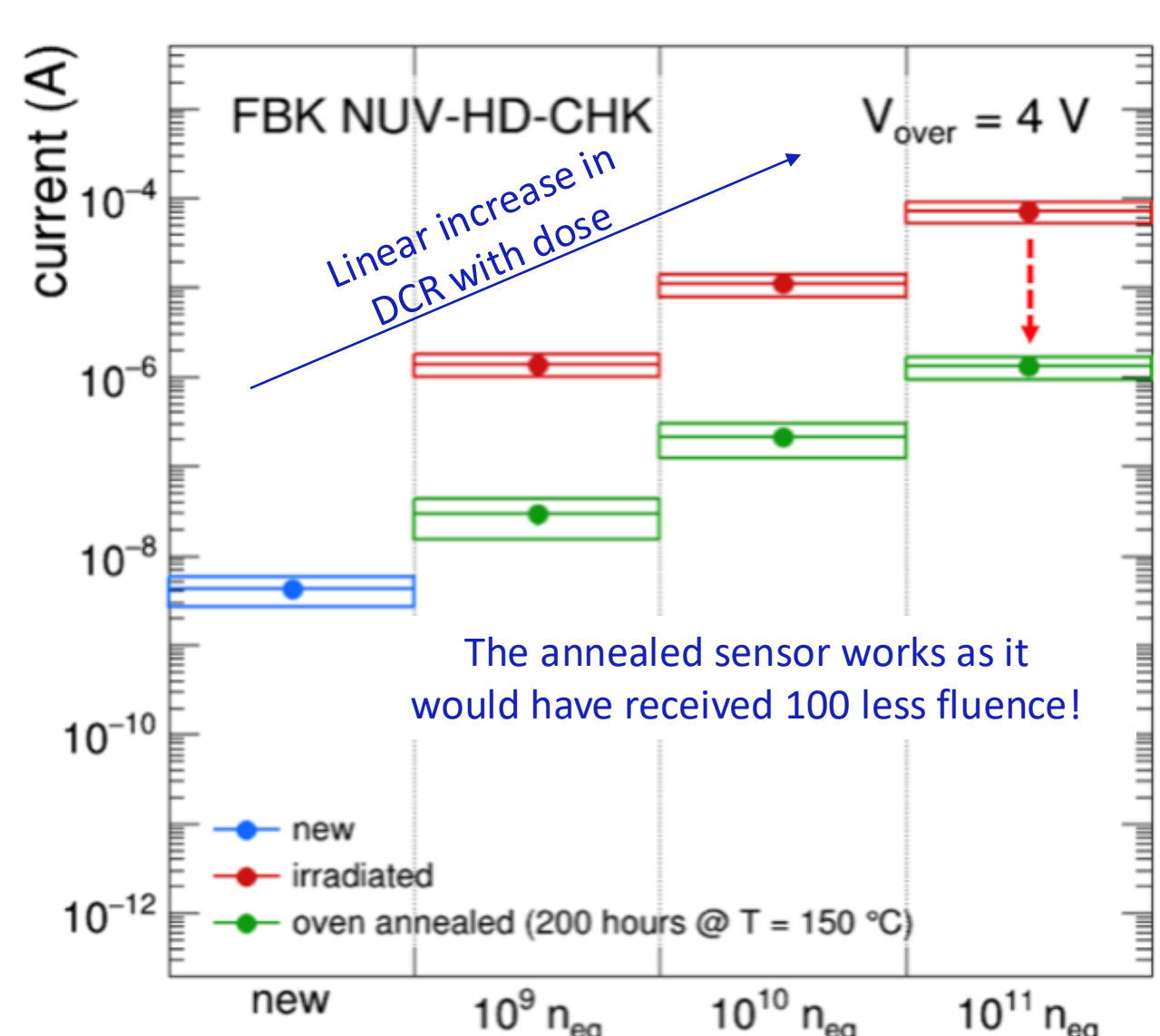

Oven annealing recovers $\sim 97-98\%$ of dark current damage.

In-situ self-induced annealing

- Started at $100 \text{ }^\circ\text{C}$
- 4 steps up to 30 hours integrated
- Followed by $125, 150, 175 \text{ }^\circ\text{C}$ annealing

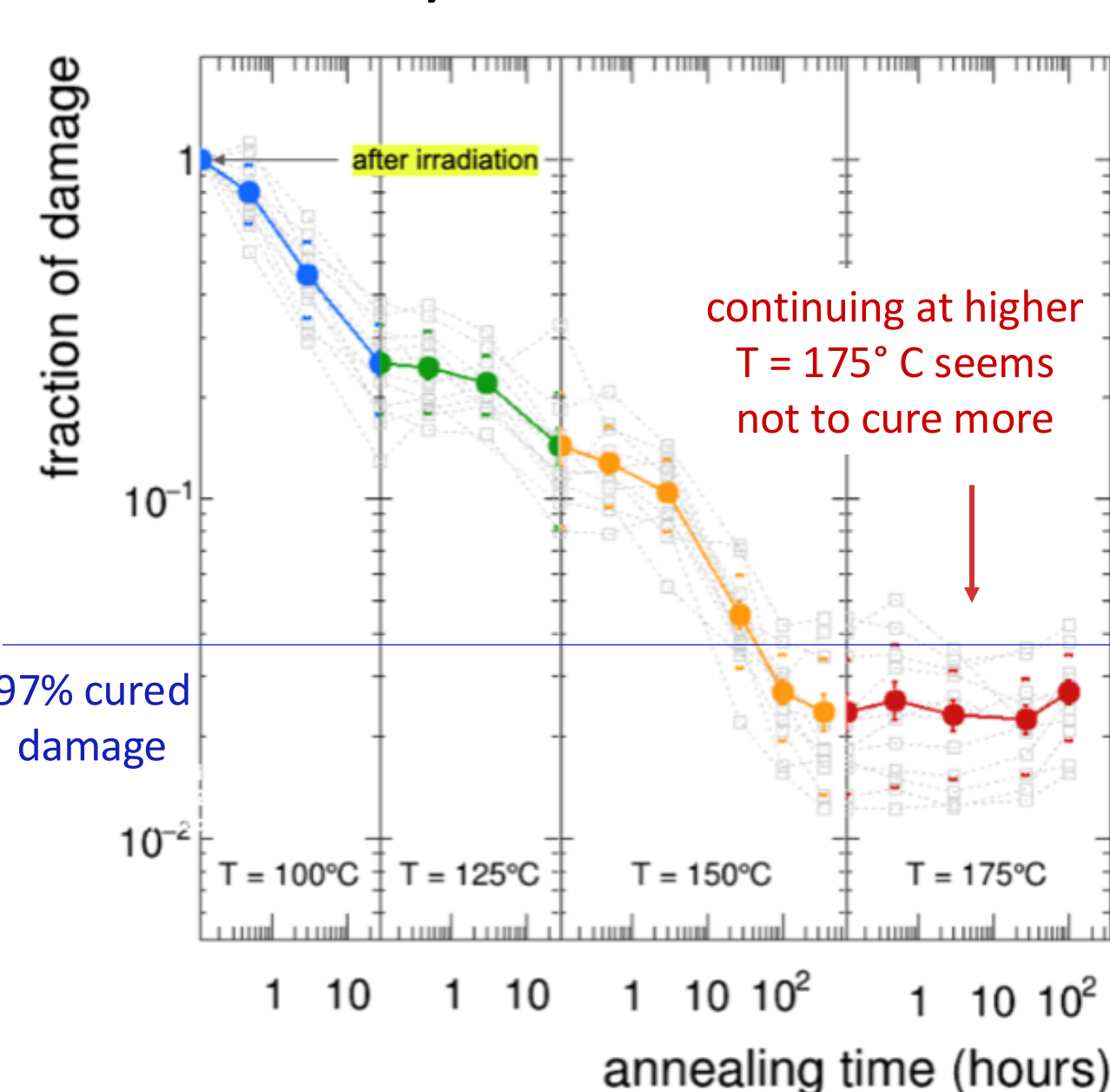

Self-annealing reduces damage saturating at 2–3% after $\sim 300\text{h}$ at $150 \text{ }^\circ\text{C}$

Radiation level

Estimates Update

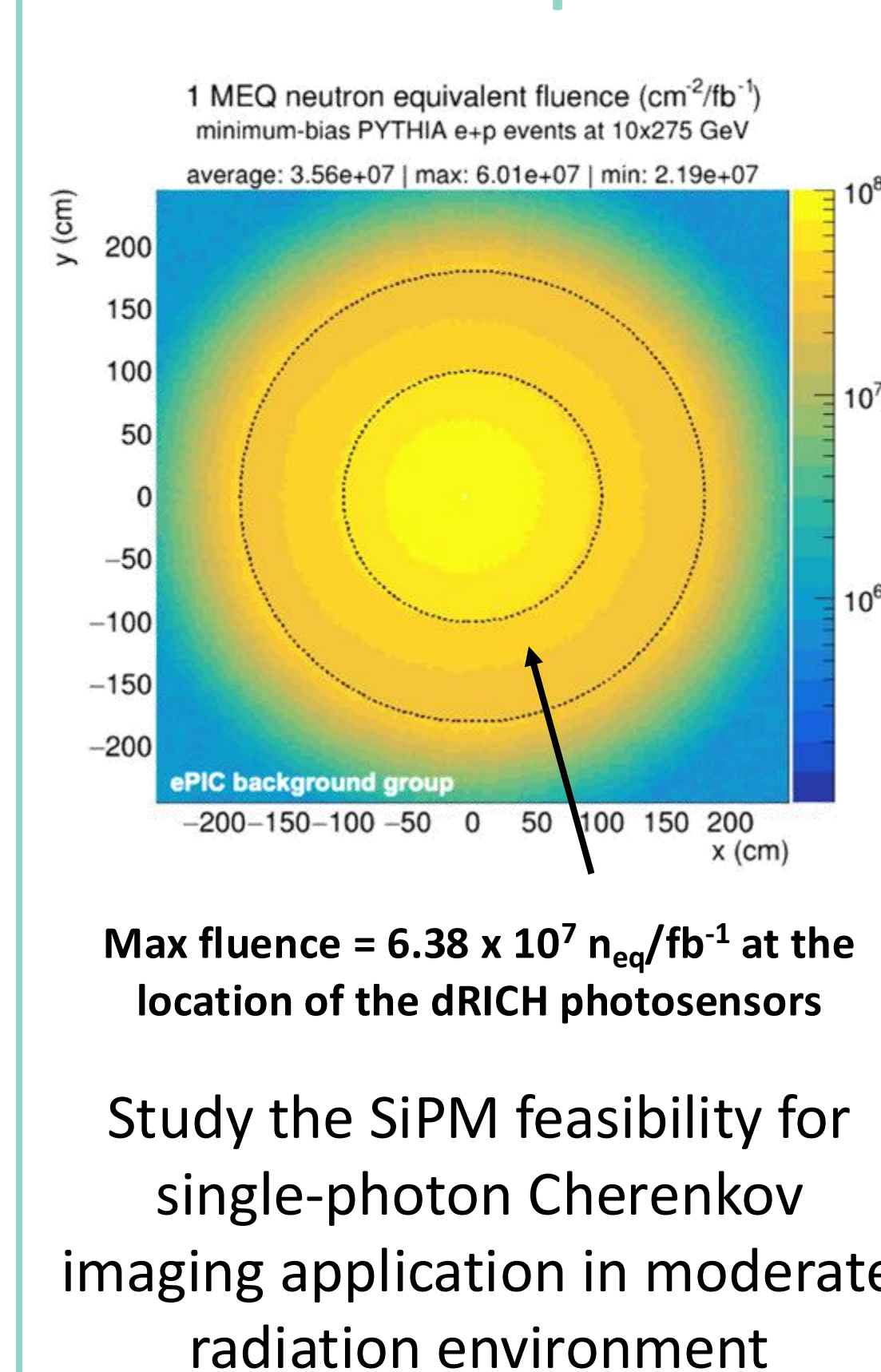

Study the SiPM feasibility for single-photon Cherenkov imaging application in moderate radiation environment

SiPM ageing

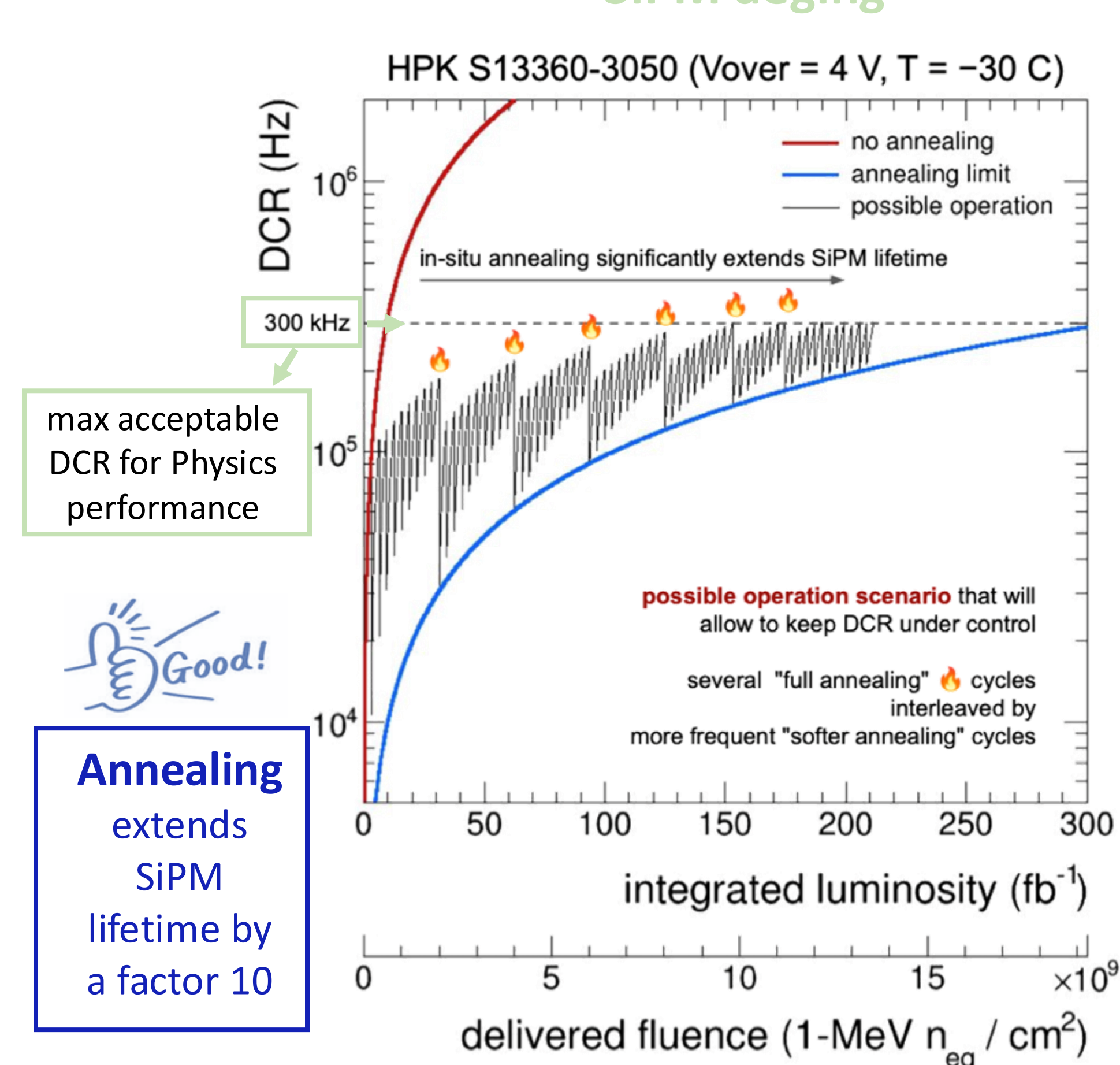

max acceptable DCR for Physics performance
Good!
Annealing extends SiPM lifetime by a factor 10

Relative Photo Detection Efficiency (PDE)

The efficiency variation as a function of the annealing temperature and integrated time indicate an efficiency loss after 100 hours of annealing at $175 \text{ }^\circ\text{C}$.

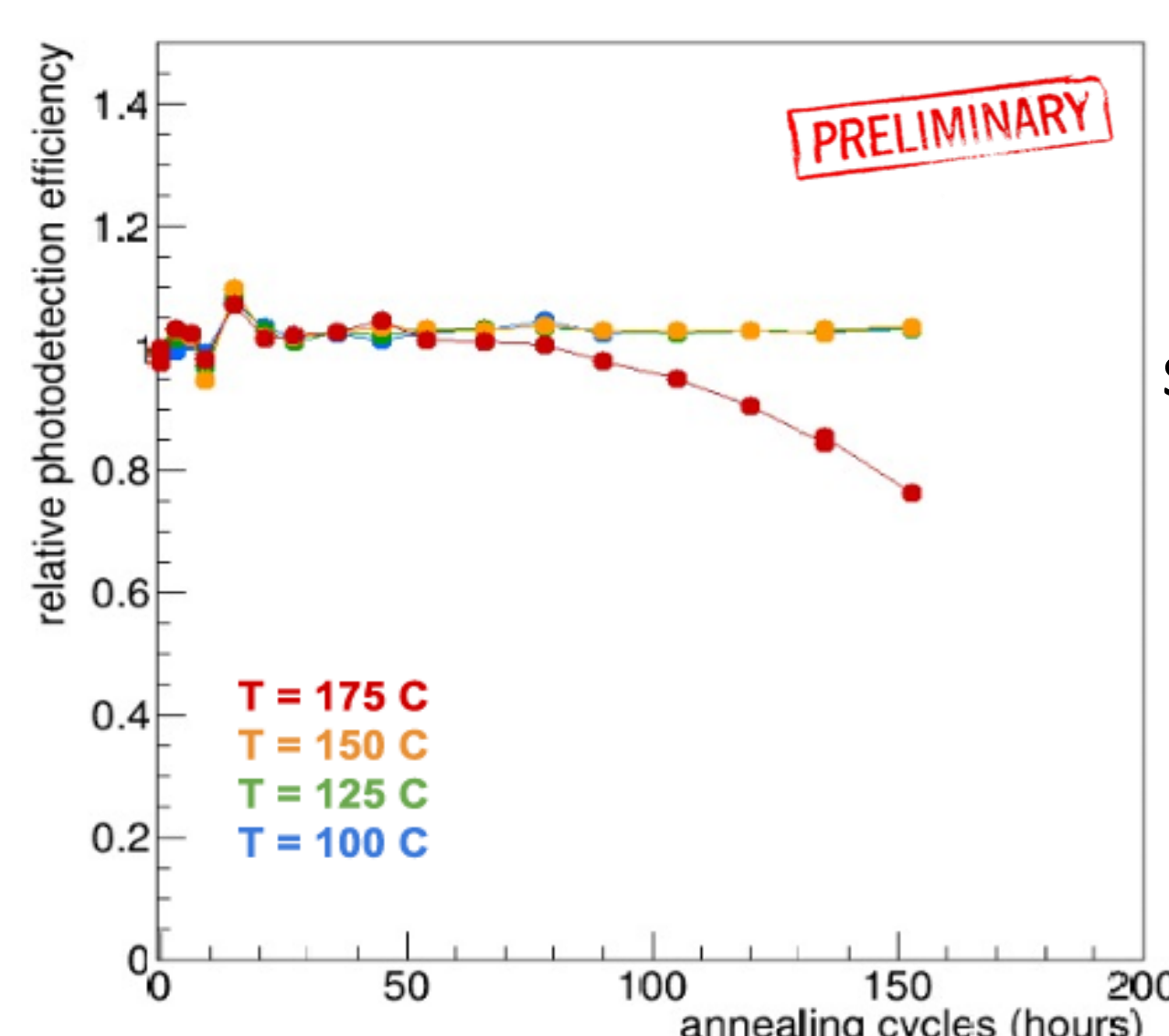

The SiPM entrance window shows changes after $\sim 500 \text{ h}$ of online annealing at $175 \text{ }^\circ\text{C}$.

no alterations observed at lower temperatures up to 150 h

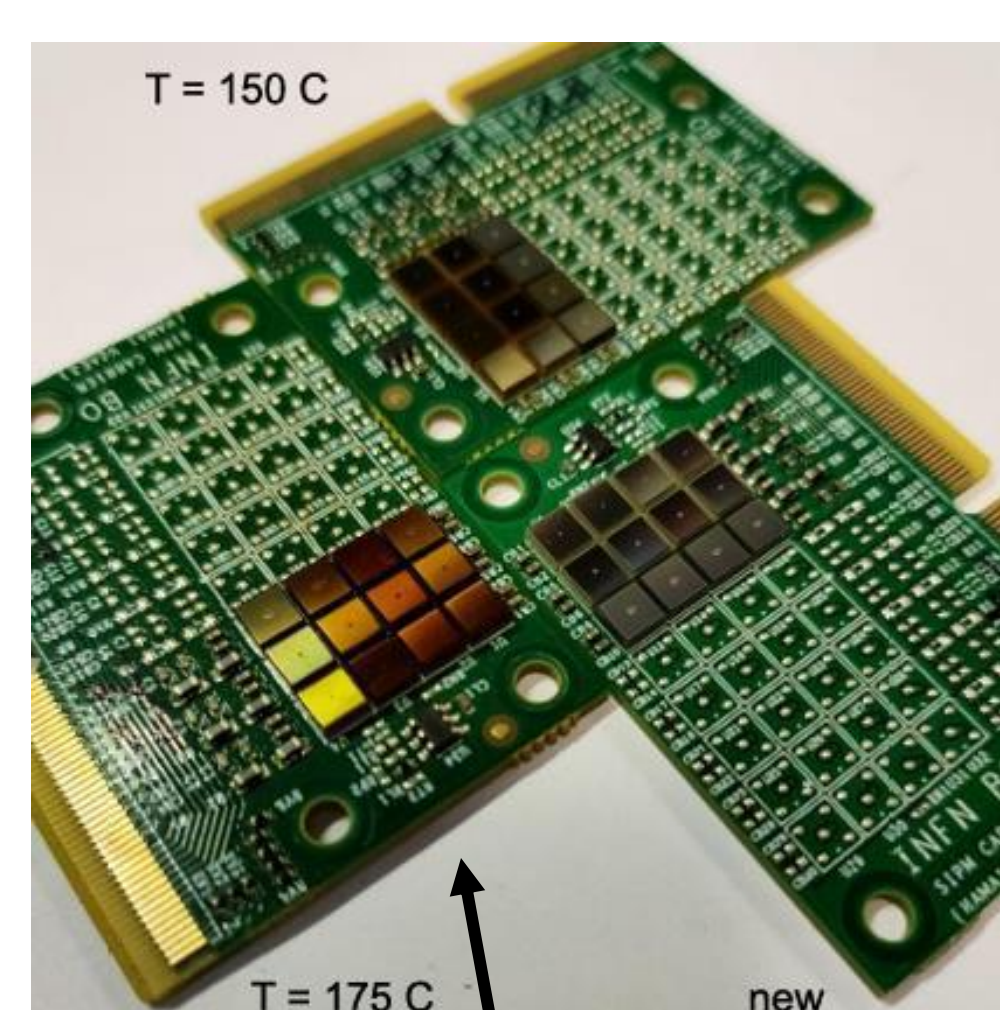

The annealed sensors exhibit a yellowish coloration compared to new ones.

Conclusions

- SiPMs meet the requirements of the dRICH detector in the ePIC experiment at EIC
- A large number of SiPMs for usability in single-photon applications in a moderate radiation environment were tested
- Radiation mitigation strategies were implemented to extend detector lifetime and stability
- Significant progress made in radiation damage mitigation with annealing were achieved
- Method validated across a range of temperature and duration
- Further improvements and sensor selection will continue