

Precision QCD with ePIC at the electron-ion collider

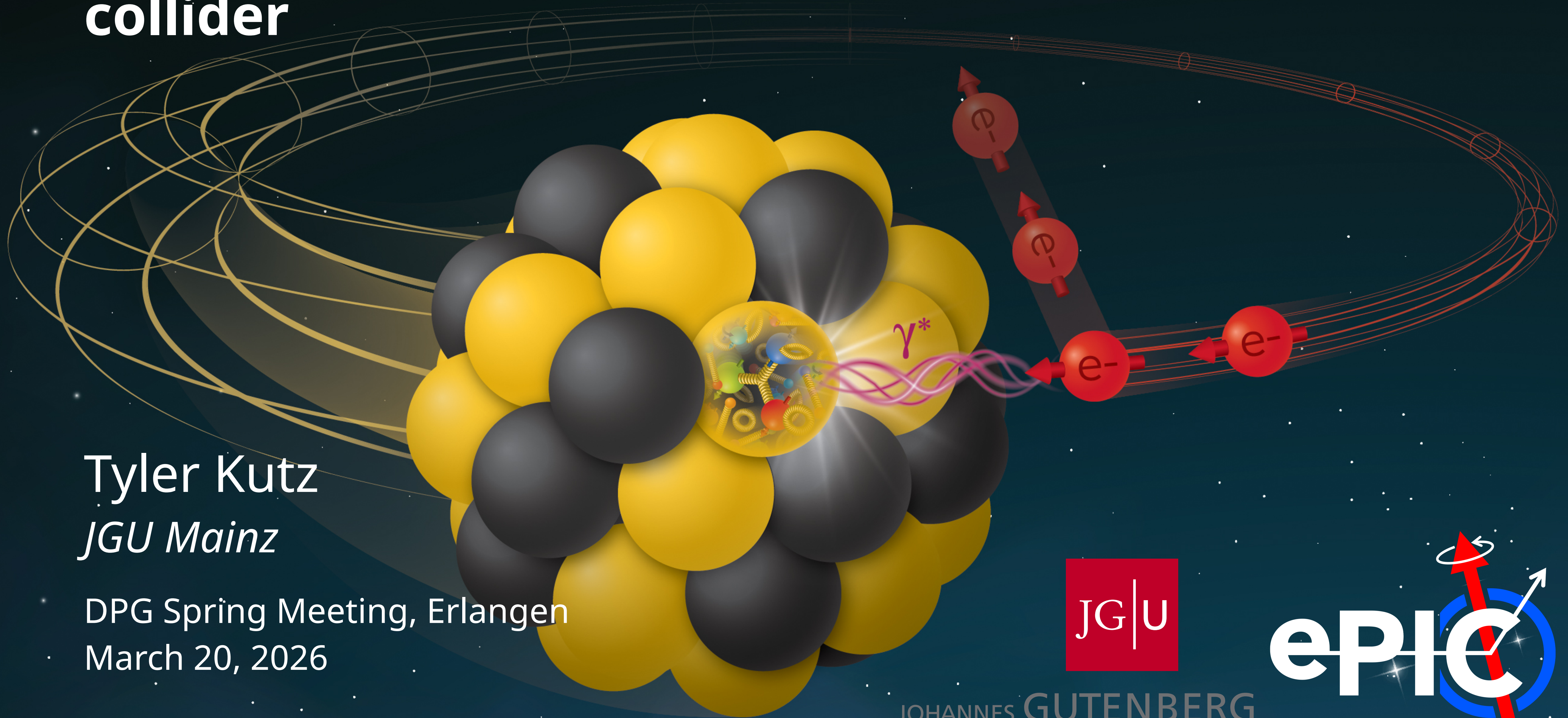

Tyler Kutz
JGU Mainz

DPG Spring Meeting, Erlangen
March 20, 2026



JOHANNES GUTENBERG
UNIVERSITÄT MAINZ



Atomic nuclei are at the heart of the visible universe



- >98% of visible matter composed of *quarks & gluons*
- Most of this matter consists of *protons & neutrons* bound in atomic nuclei

Atomic nuclei are at the heart of the visible universe

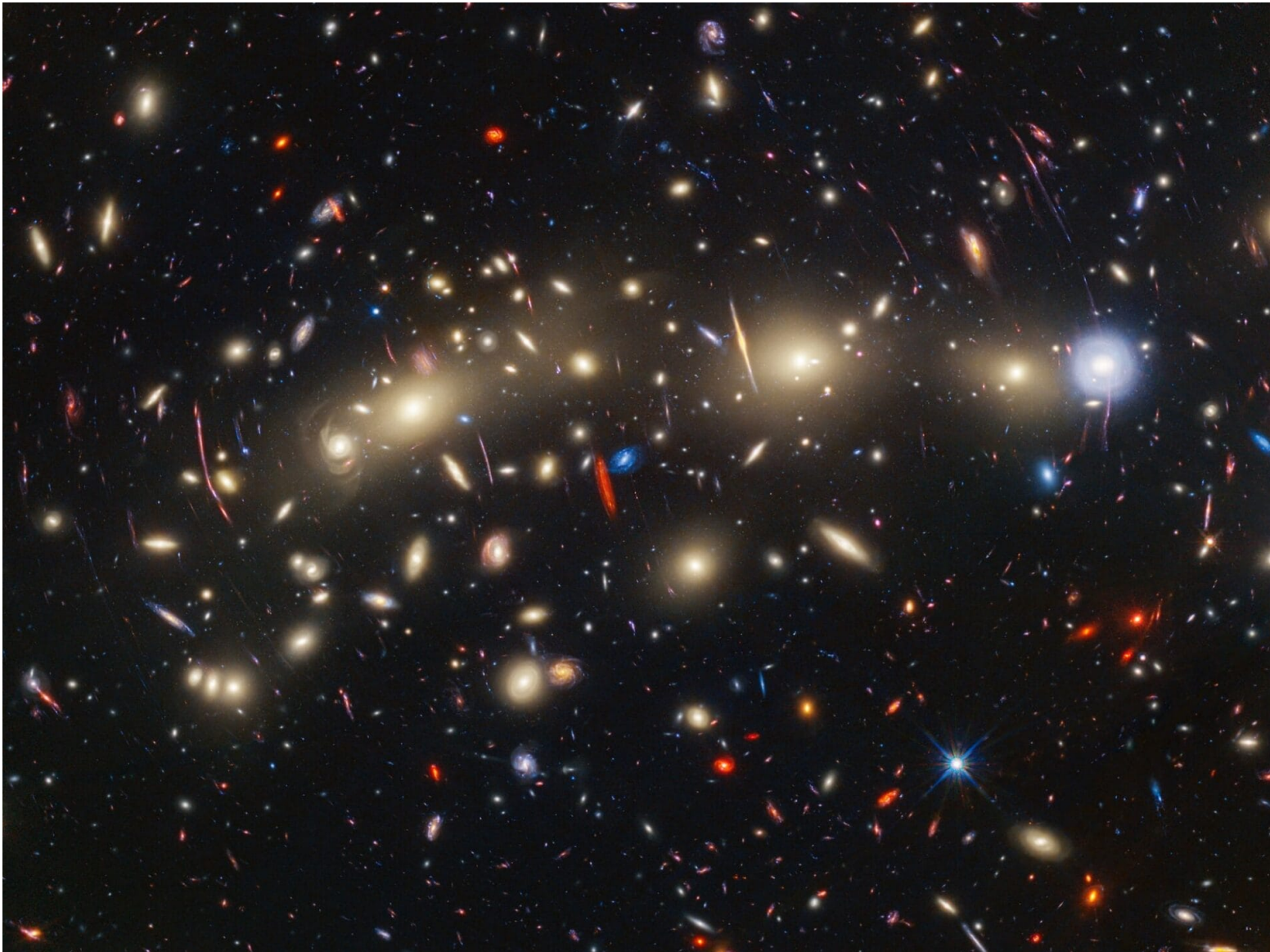

- >98% of visible matter composed of **quarks & gluons**
- Most of this matter consists of **protons & neutrons** bound in atomic nuclei

Quantum chromodynamics (QCD)

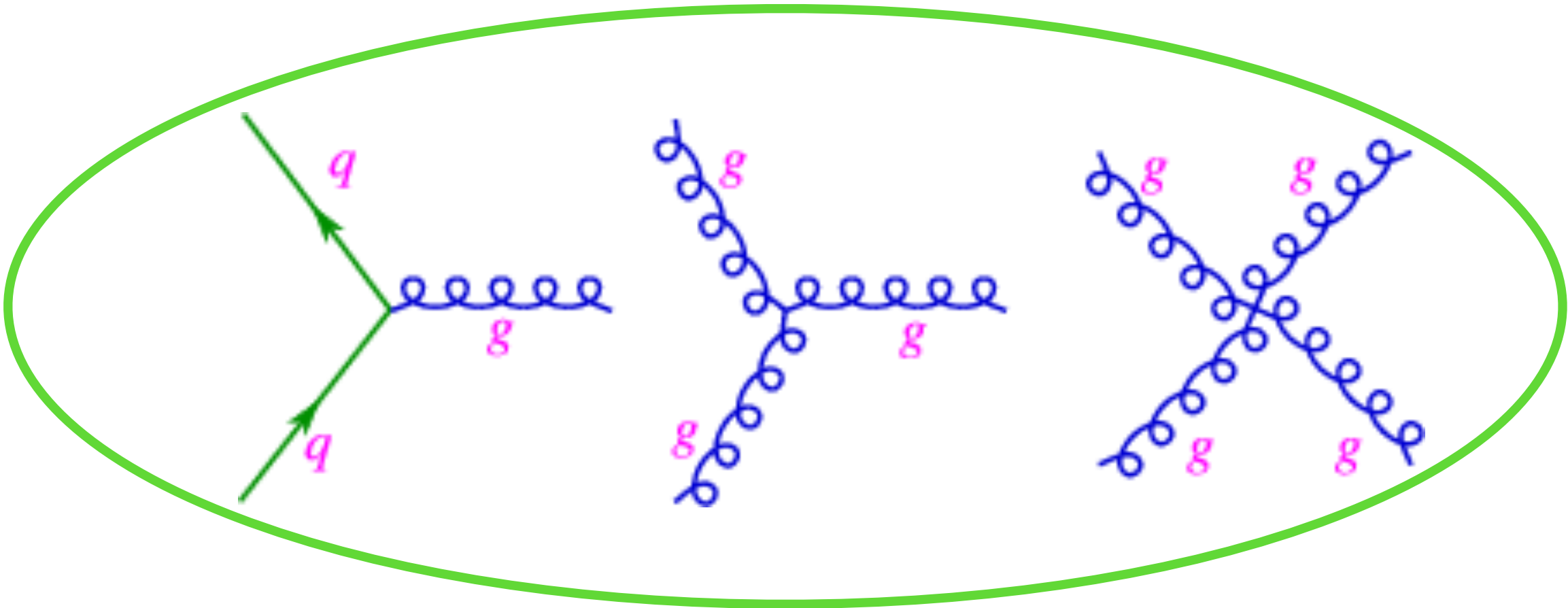

Atomic nuclei are at the heart of the visible universe

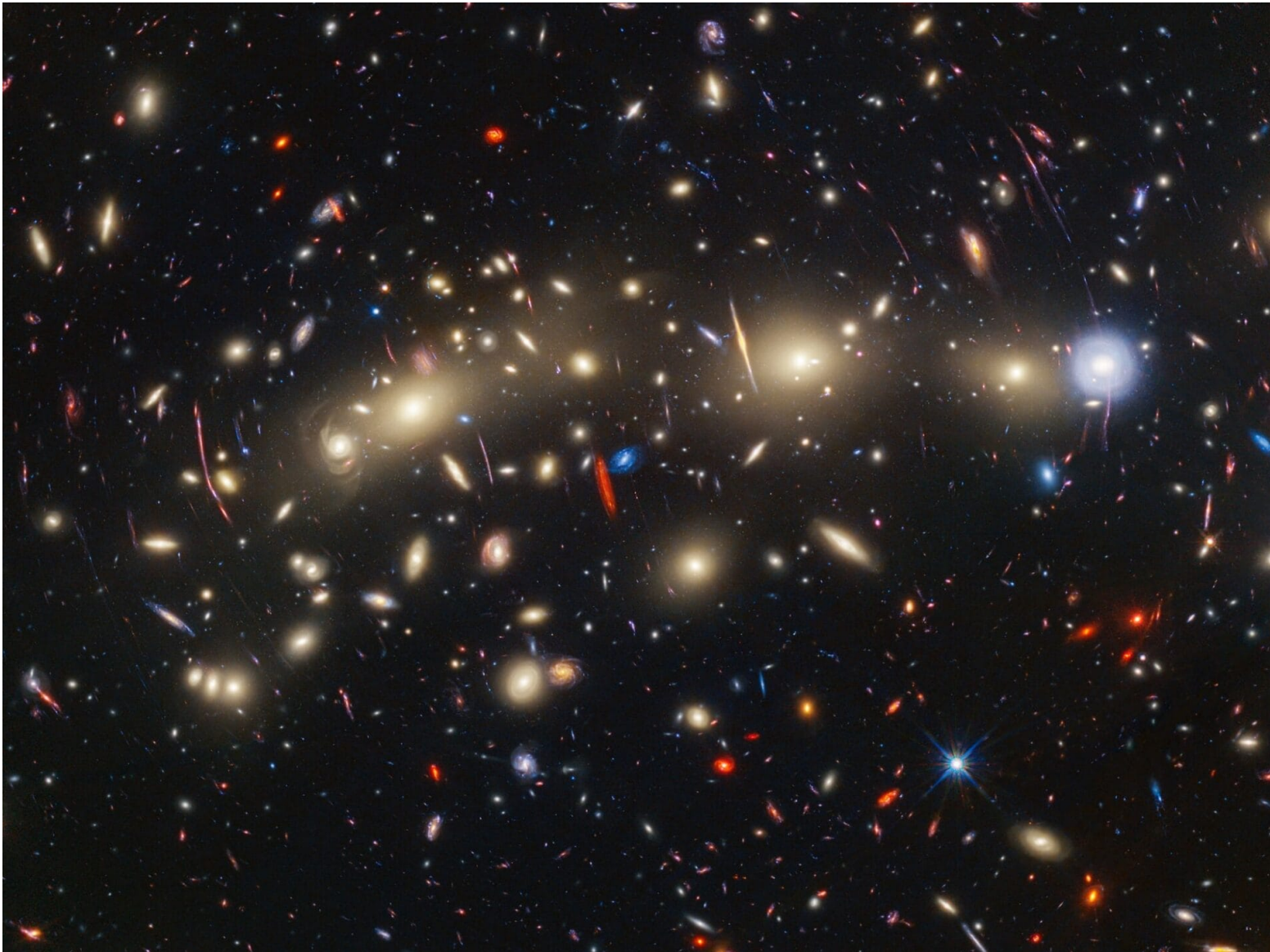

- >98% of visible matter composed of **quarks & gluons**
- Most of this matter consists of **protons & neutrons** bound in atomic nuclei

Quantum chromodynamics (QCD)

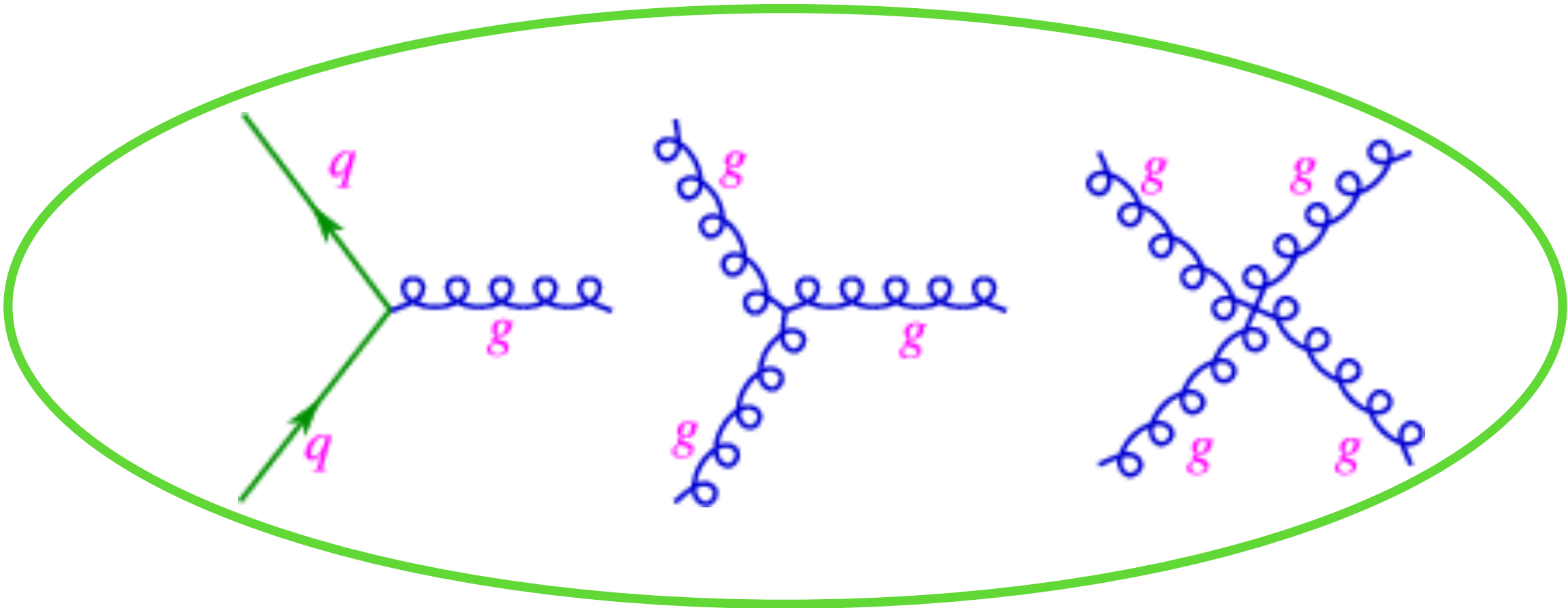

Nucleon spin?

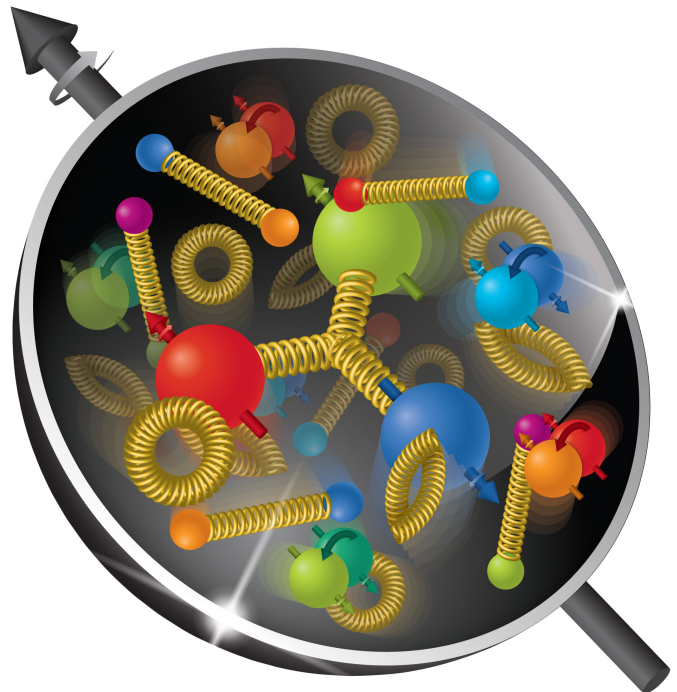

Nucleon mass?

Nuclear structure?

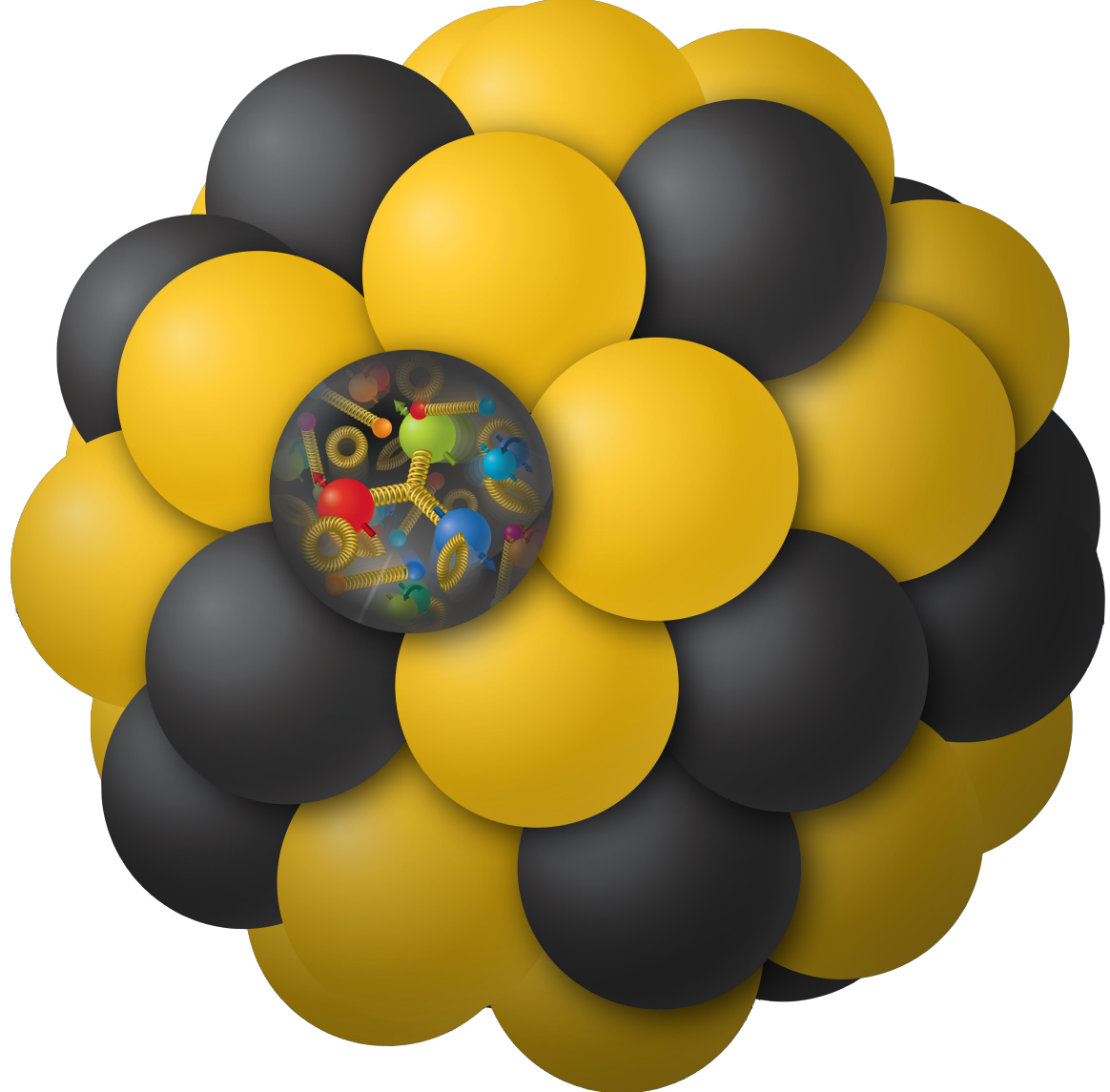

Quarks probed with deep inelastic scattering (DIS)

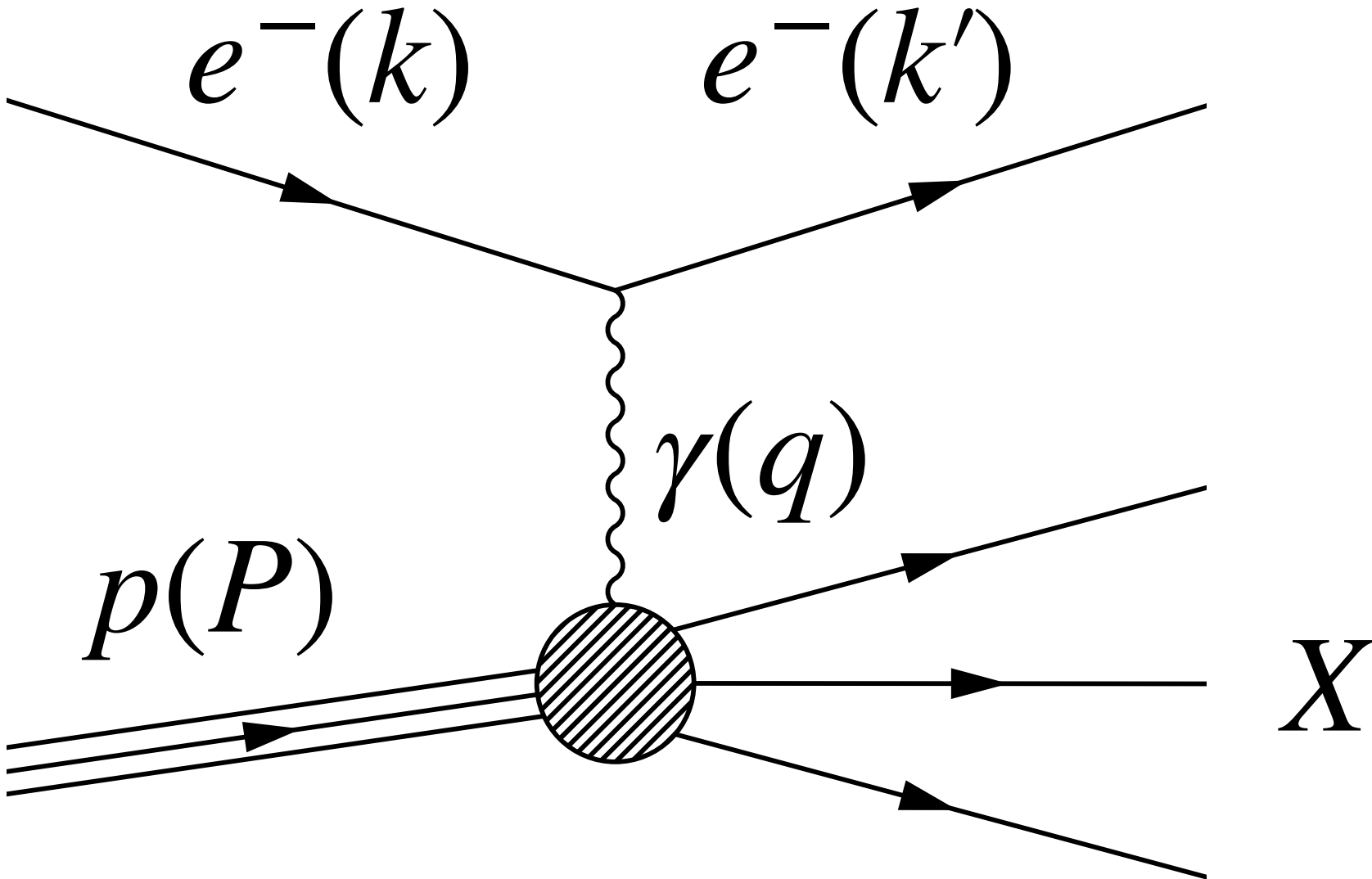

Quarks probed with deep inelastic scattering (DIS)

Detect scattered electron

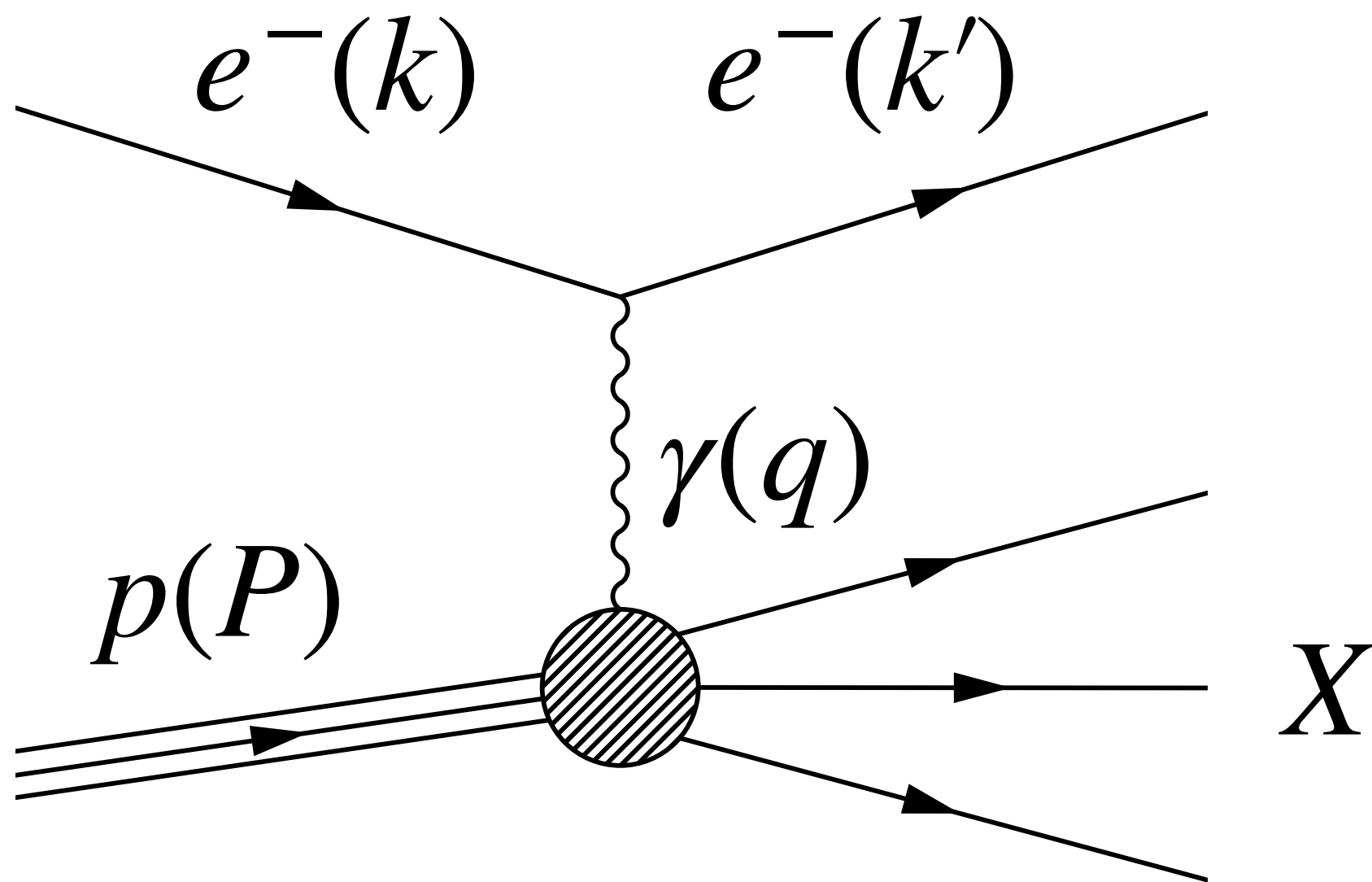

$$Q^2 = -q^2 = (k' - k)^2$$

$$x_B = \frac{Q^2}{2P \cdot q}$$

$$y = \frac{P \cdot q}{P \cdot k}$$

Quarks probed with deep inelastic scattering (DIS)

Detect scattered electron

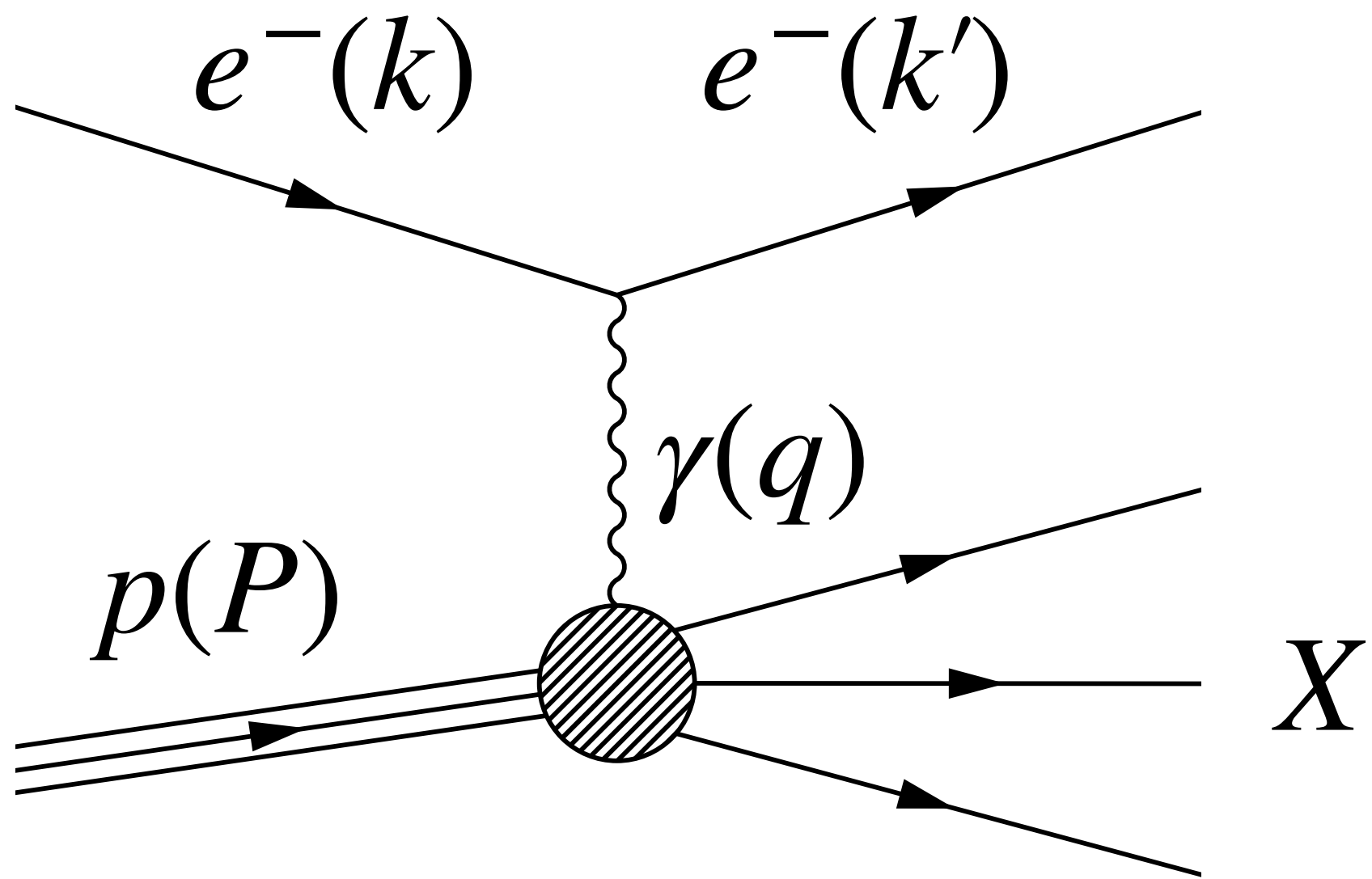

$$Q^2 = -q^2 = (k' - k)^2$$

$$x_B = \frac{Q^2}{2P \cdot q}$$

$$y = \frac{P \cdot q}{P \cdot k}$$

Quarks probed with deep inelastic scattering (DIS)

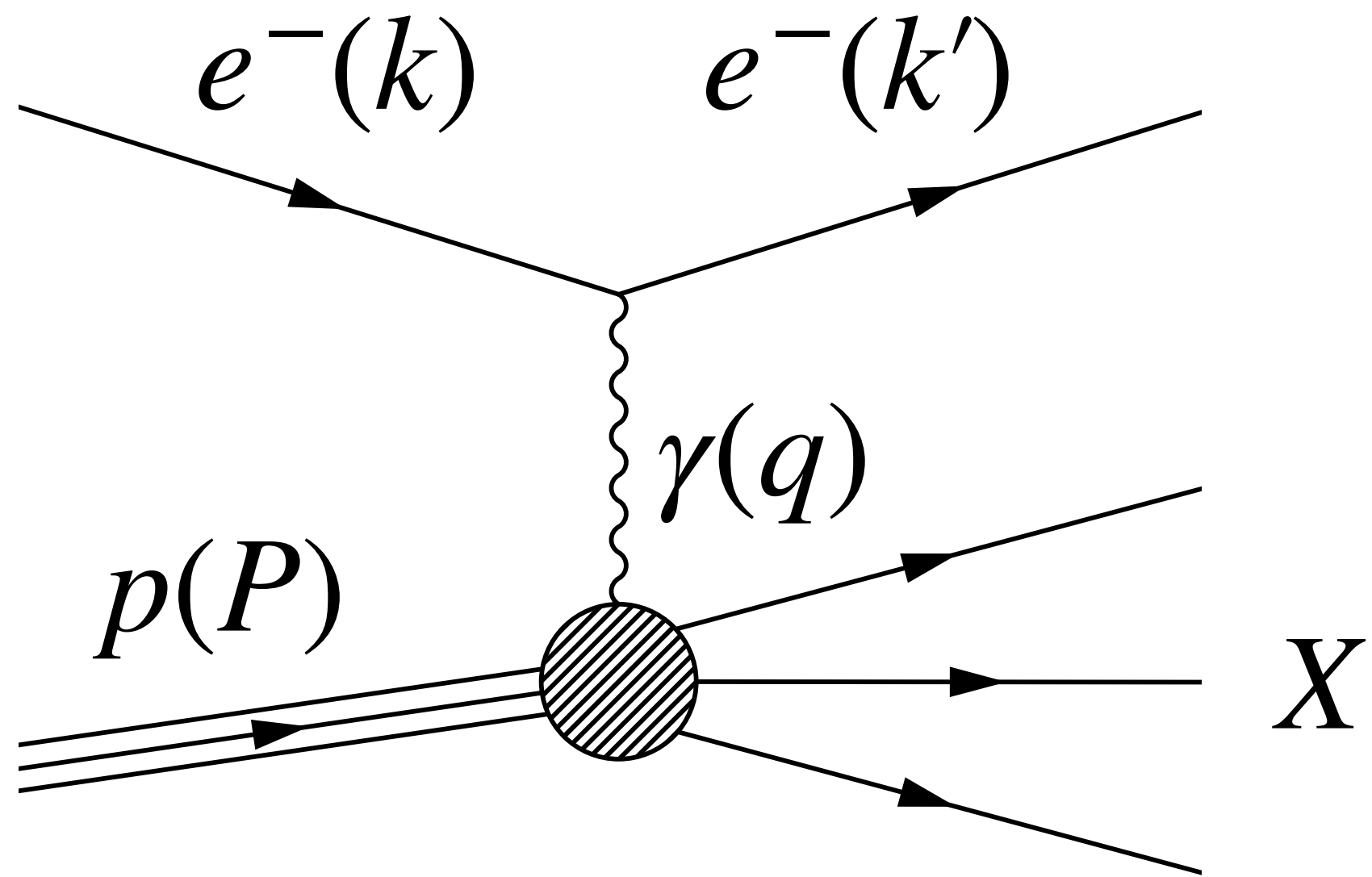

Detect scattered electron

$$Q^2 = -q^2 = (k' - k)^2$$



$$x_B = \frac{Q^2}{2P \cdot q}$$



$$y = \frac{P \cdot q}{P \cdot k}$$

Quarks probed with deep inelastic scattering (DIS)

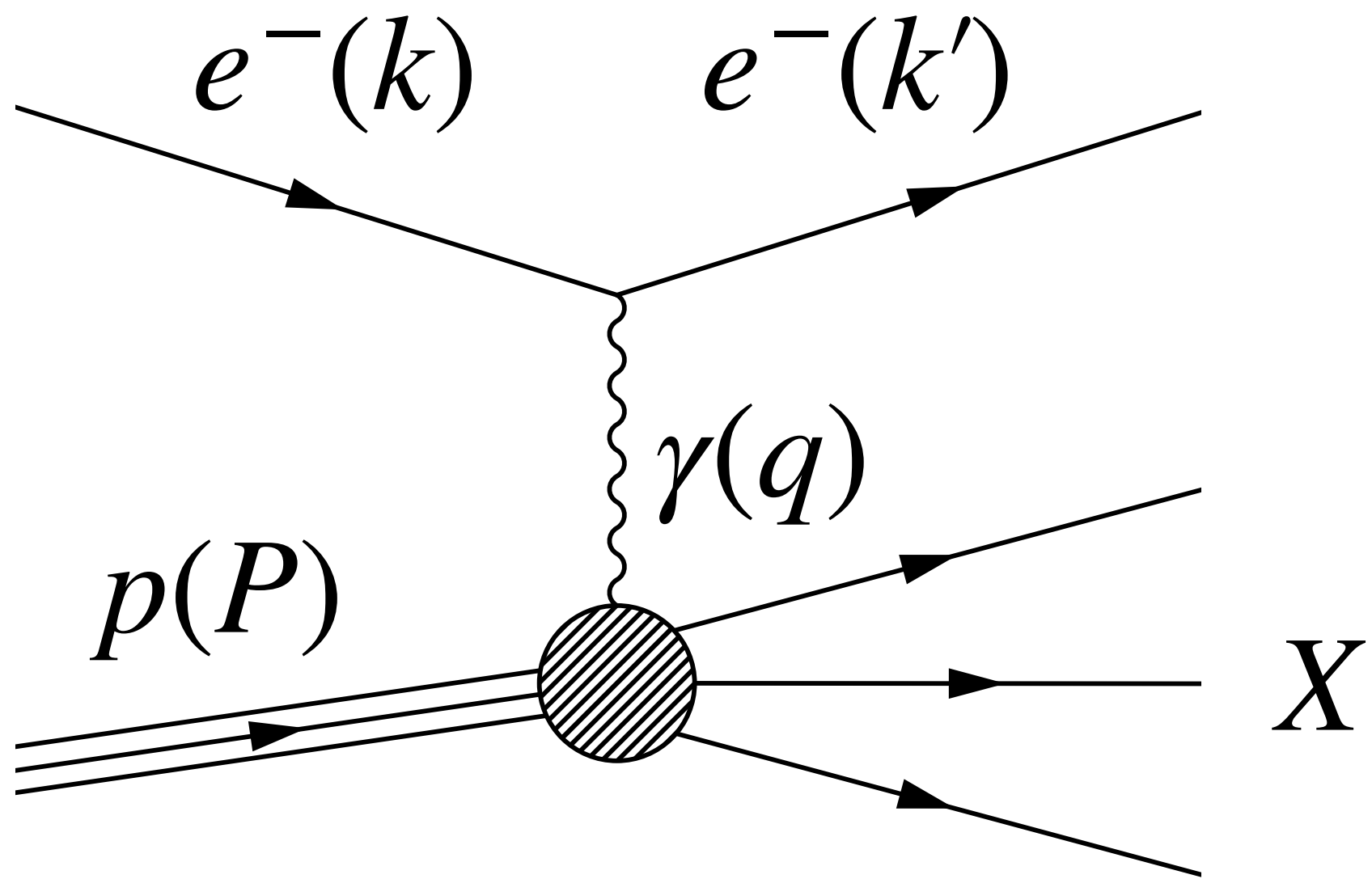

Detect scattered electron

$$Q^2 = -q^2 = (k' - k)^2$$



$$x_B = \frac{Q^2}{2P \cdot q}$$



$$y = \frac{P \cdot q}{P \cdot k}$$



If we want to study partons, why not maximize number of partons with AA collisions?

If we want to study partons, why not maximize number of partons with AA collisions?

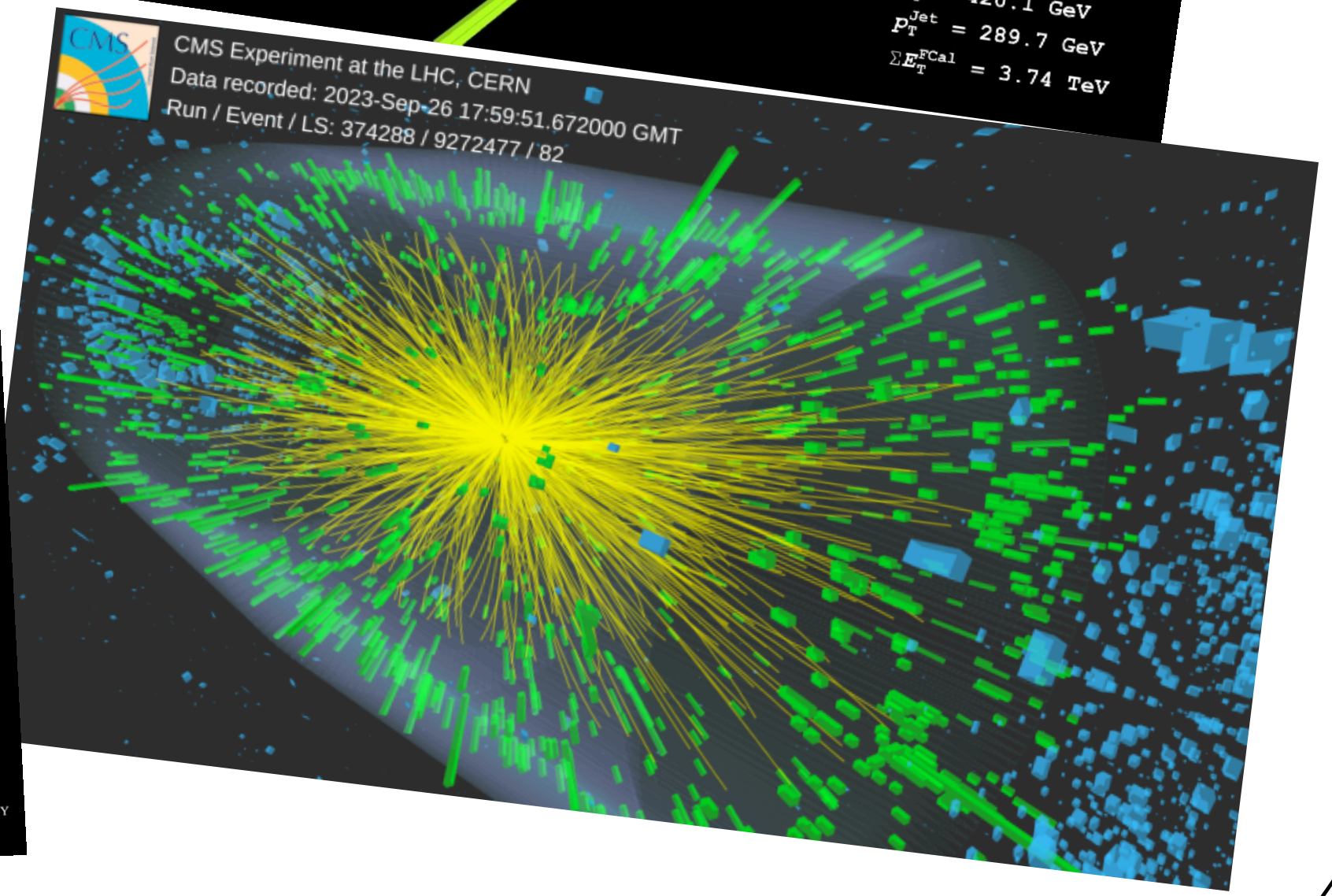
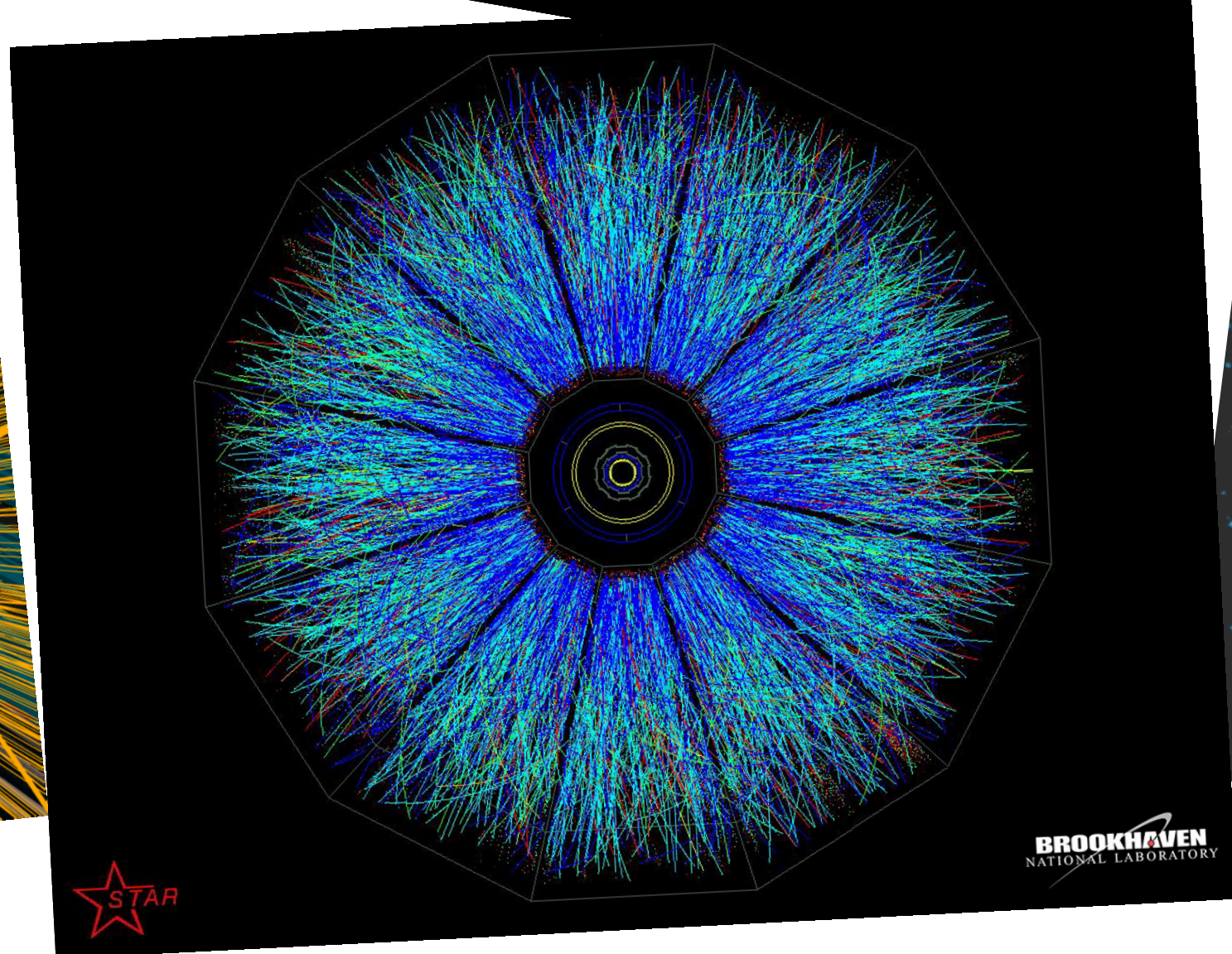
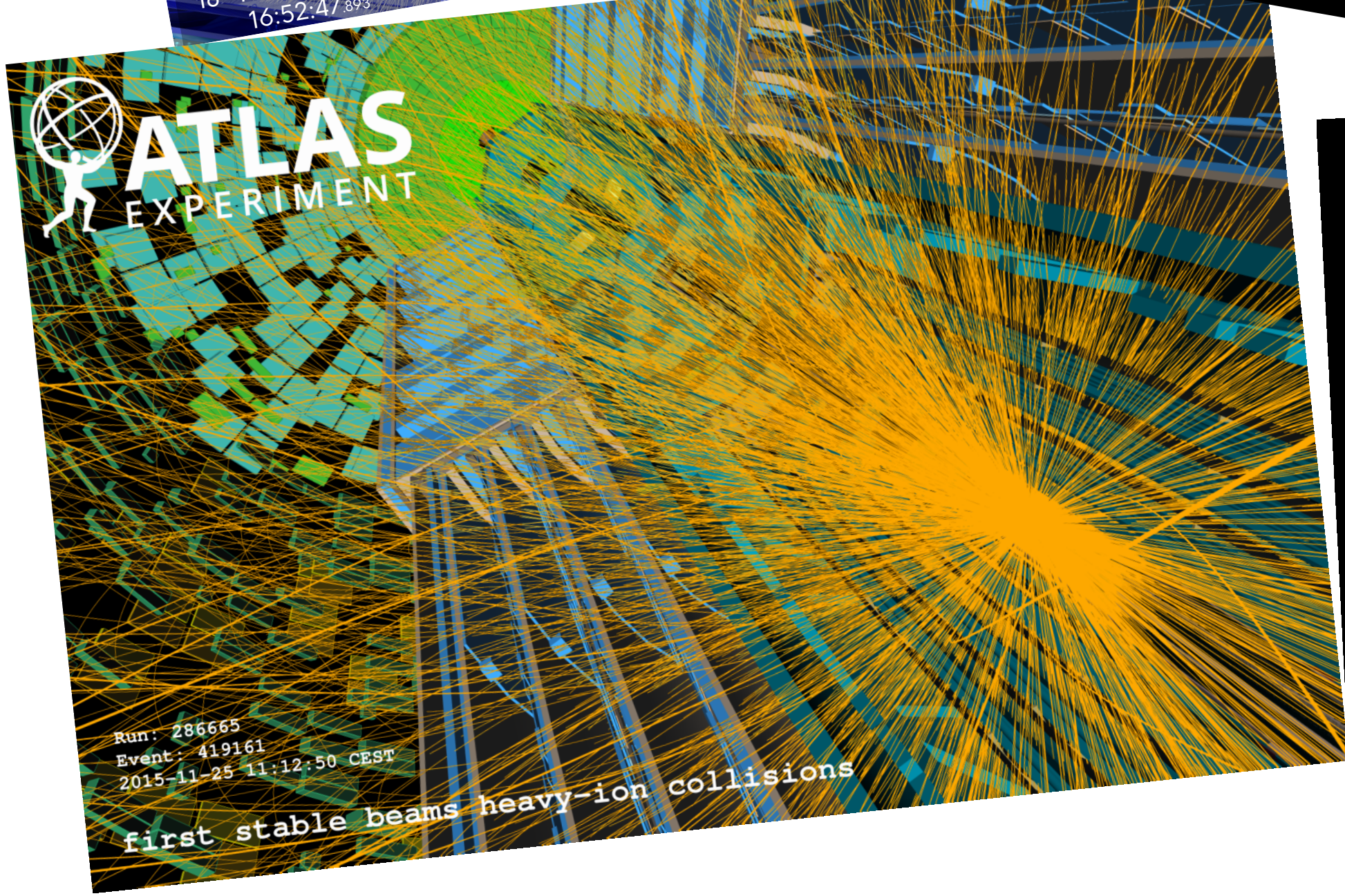
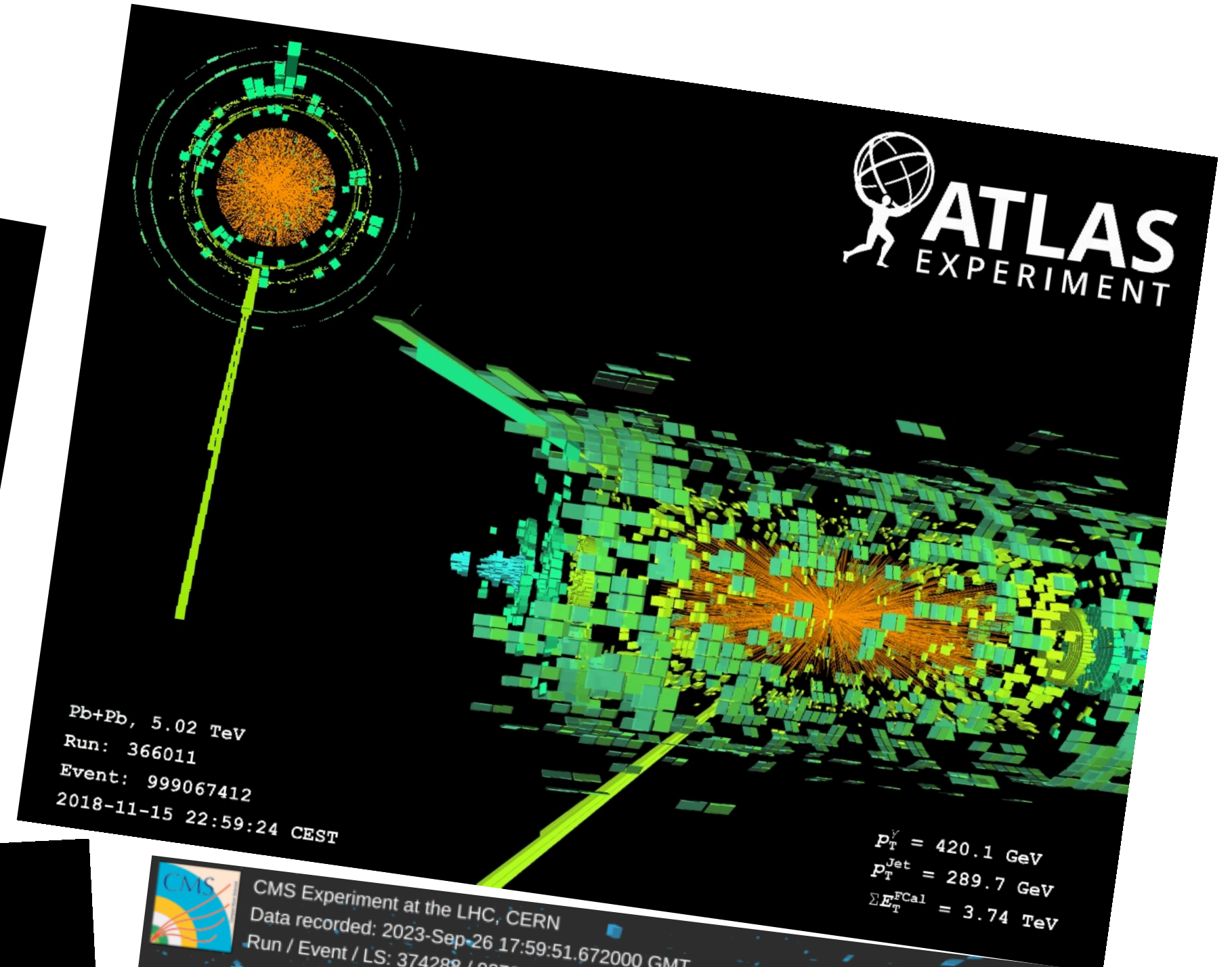
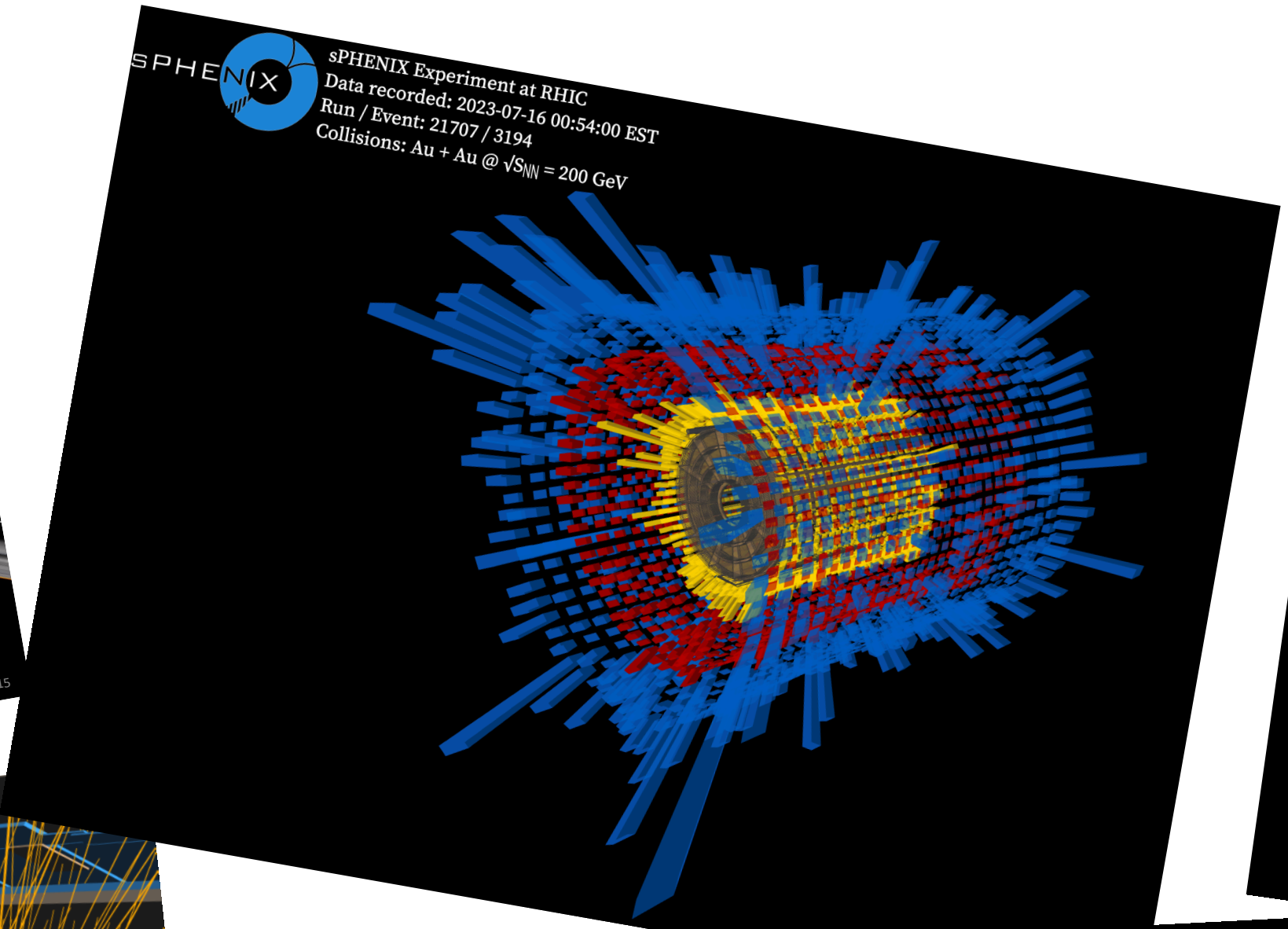
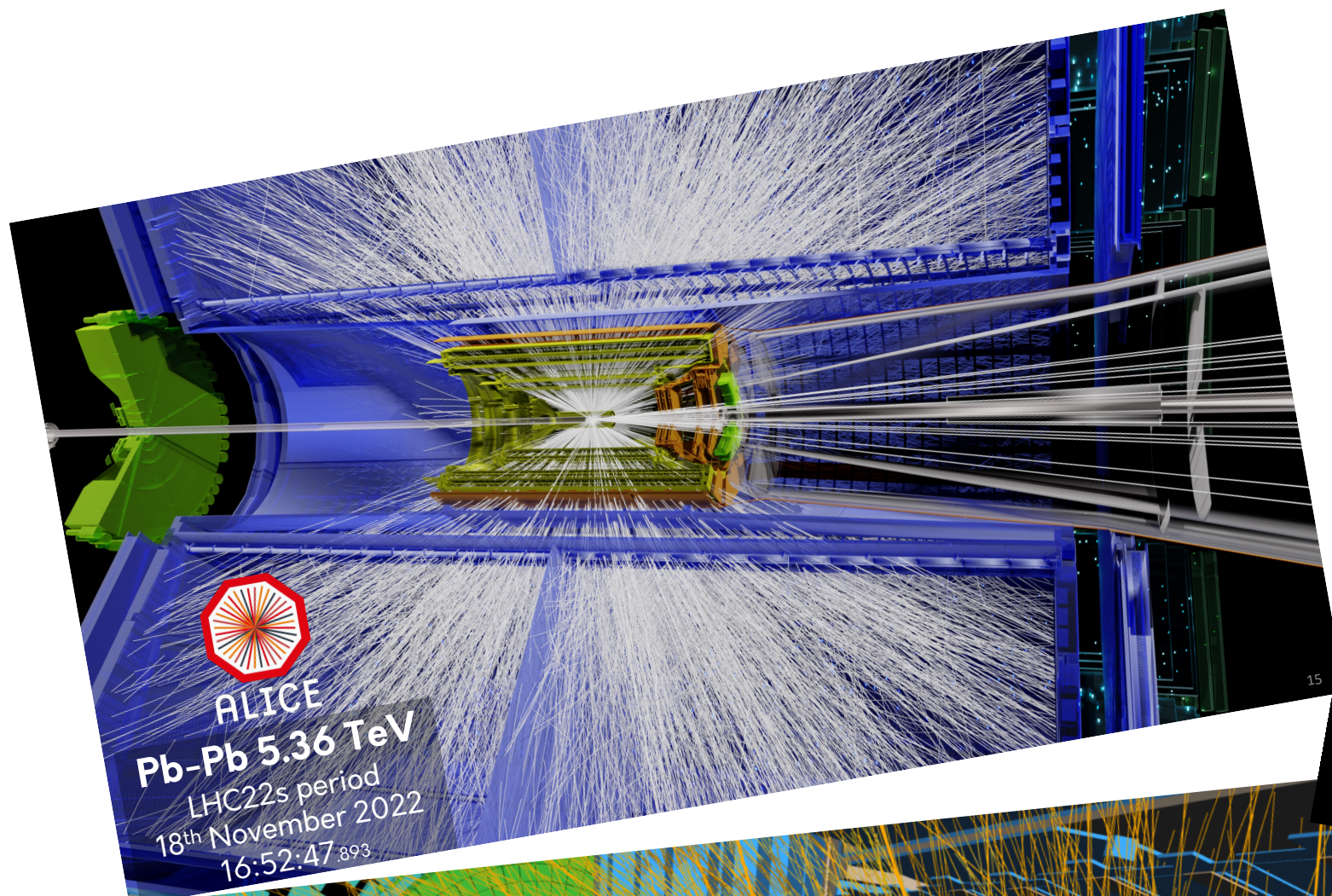

Studying the internal structure of watermelon...

Studying the internal structure of watermelon...



Heavy ion collisions

Studying the internal structure of watermelon...



Heavy ion collisions

Electron scattering



DIS cross section proportional to parton distributions

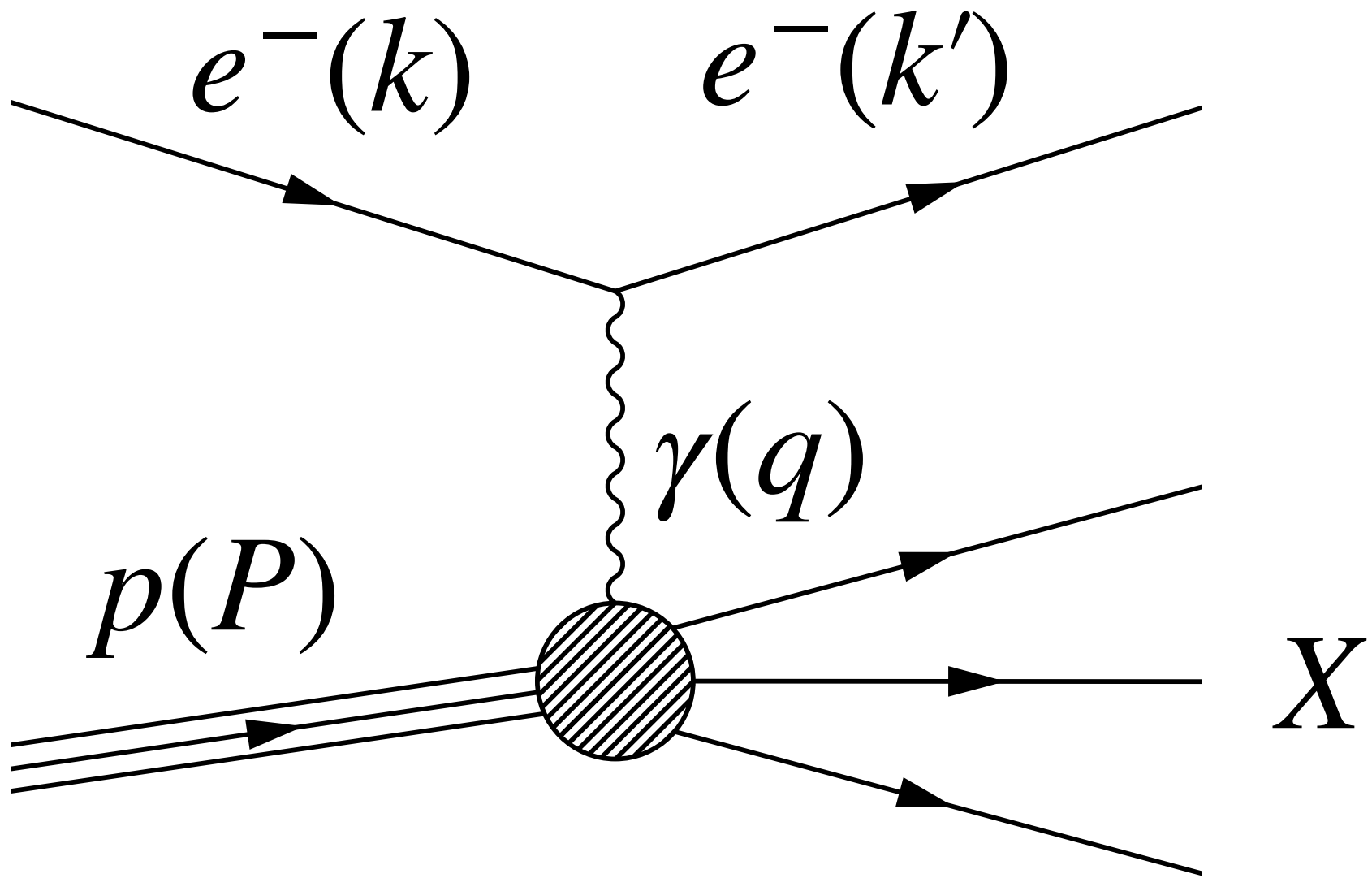

$$\frac{d\sigma}{dx dQ^2} = \frac{2\pi\alpha^2}{xyQ^4} \left[(1 + (1 - y)^2) F_2 - y^2 F_L \right]$$

DIS cross section proportional to parton distributions

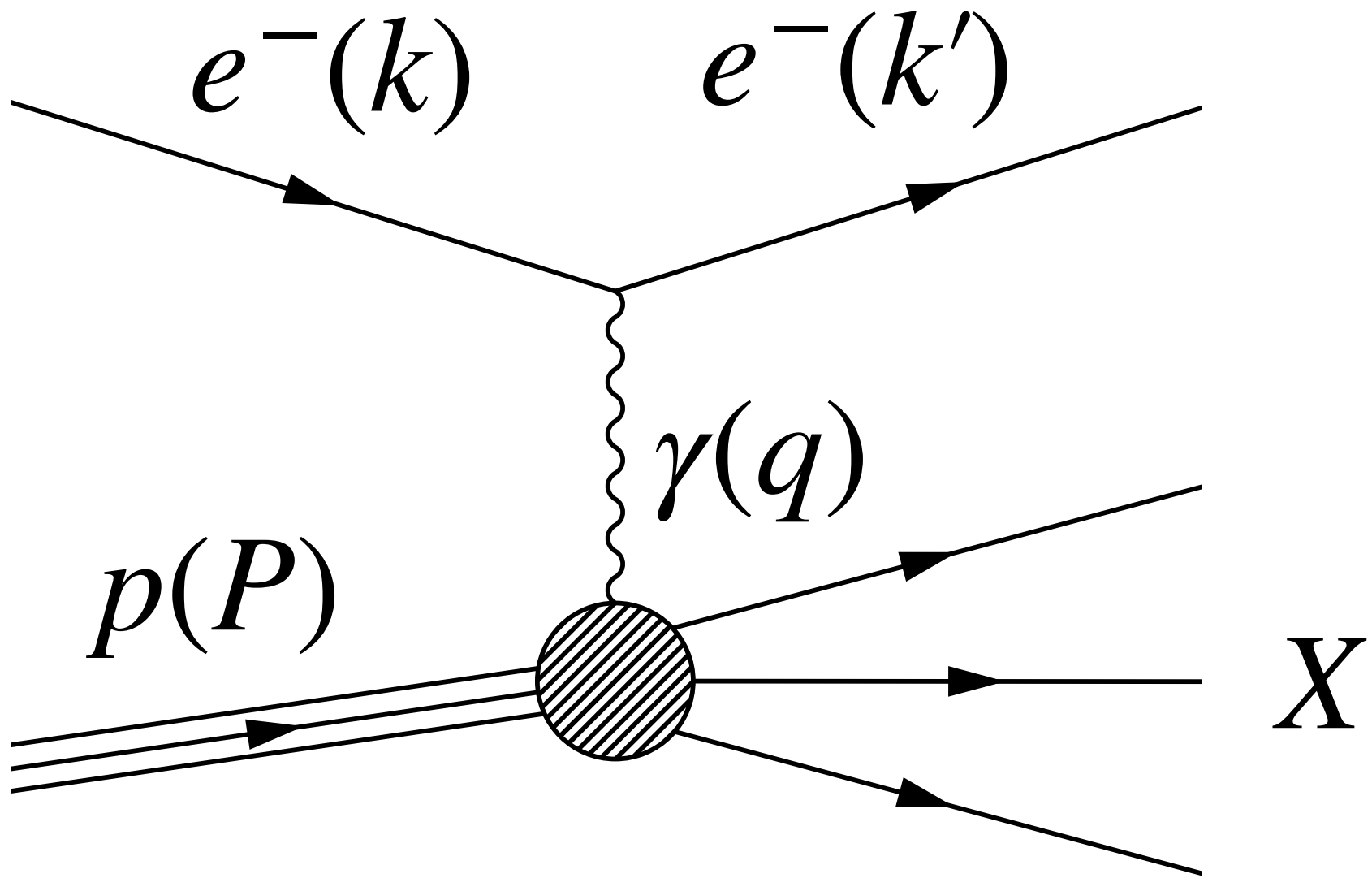

$$\frac{d\sigma}{dx dQ^2} = \frac{2\pi\alpha^2}{xyQ^4} \left[(1 + (1 - y)^2) F_2 - y^2 F_L \right]$$

$$F_2 = x \sum_q e_q^2 (q + \bar{q})$$

DIS cross section proportional to parton distributions

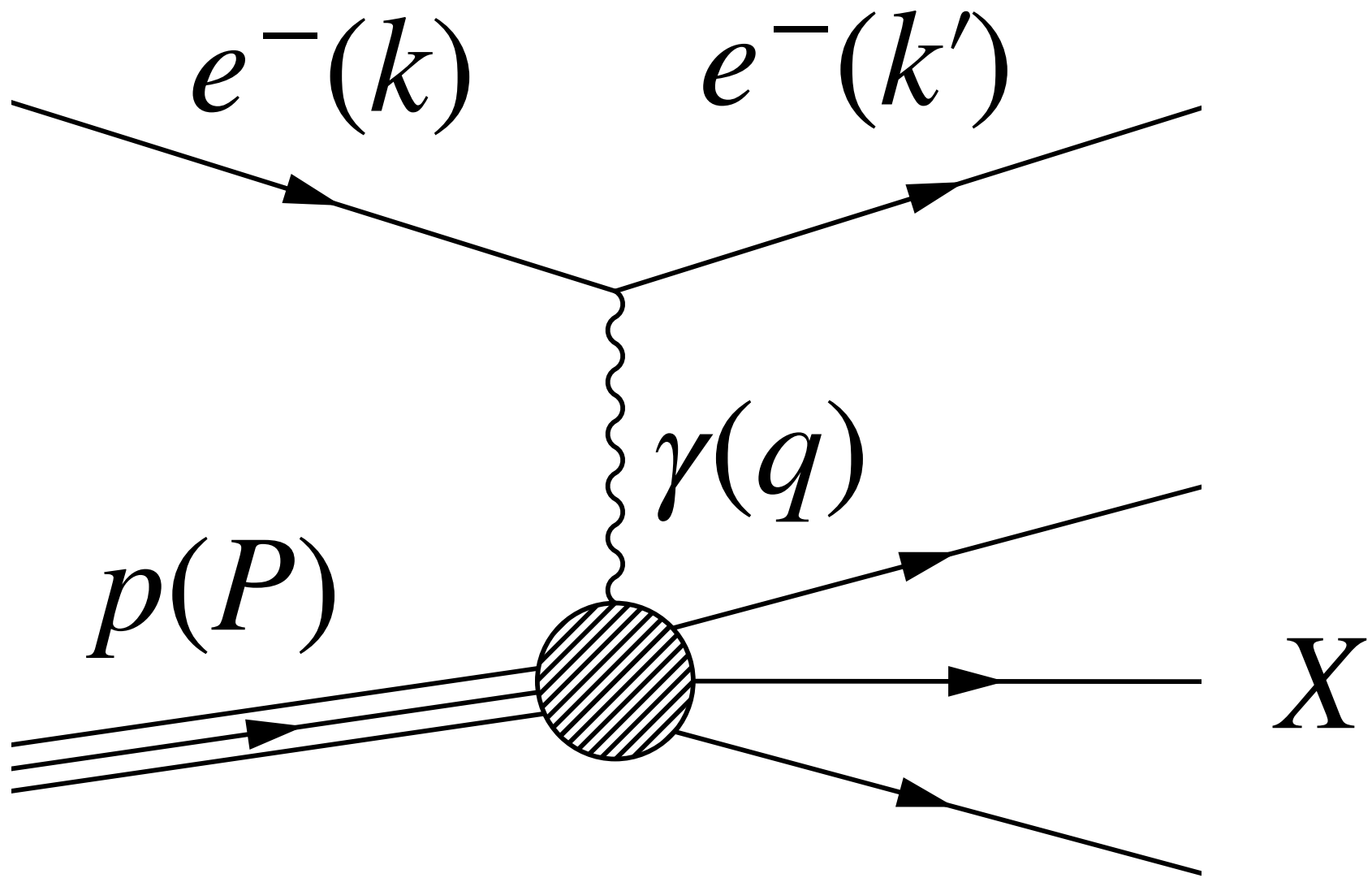

$$\frac{d\sigma}{dx dQ^2} = \frac{2\pi\alpha^2}{xyQ^4} \left[(1 + (1 - y)^2) F_2 - y^2 F_L \right]$$

$$F_2 = x \sum_q e_q^2 (q + \bar{q})$$

parton distribution functions

DIS cross section proportional to parton distributions

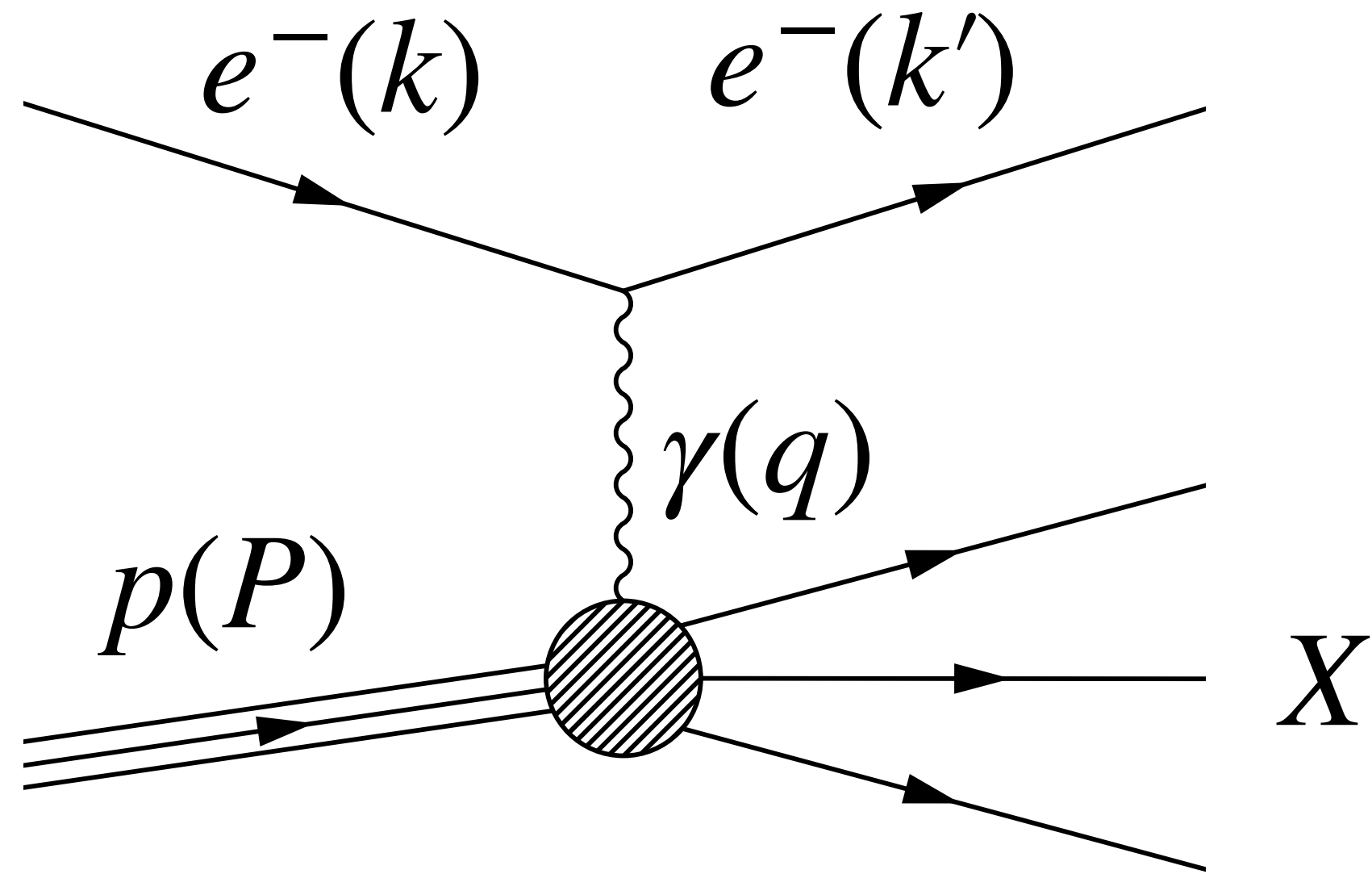

$$\frac{d\sigma}{dx dQ^2} = \frac{2\pi\alpha^2}{xyQ^4} \left[(1 + (1 - y)^2) F_2 - y^2 F_L \right]$$

$$F_2 = x \sum_q e_q^2 (q + \bar{q})$$

parton
distribution
functions

- Longitudinal momentum fraction
- Quark-parton model
→ PDFs depend only on x (scaling)
- Quantum chromodynamics
→ Q^2 dependence (scaling violation)

DIS cross section proportional to parton distributions

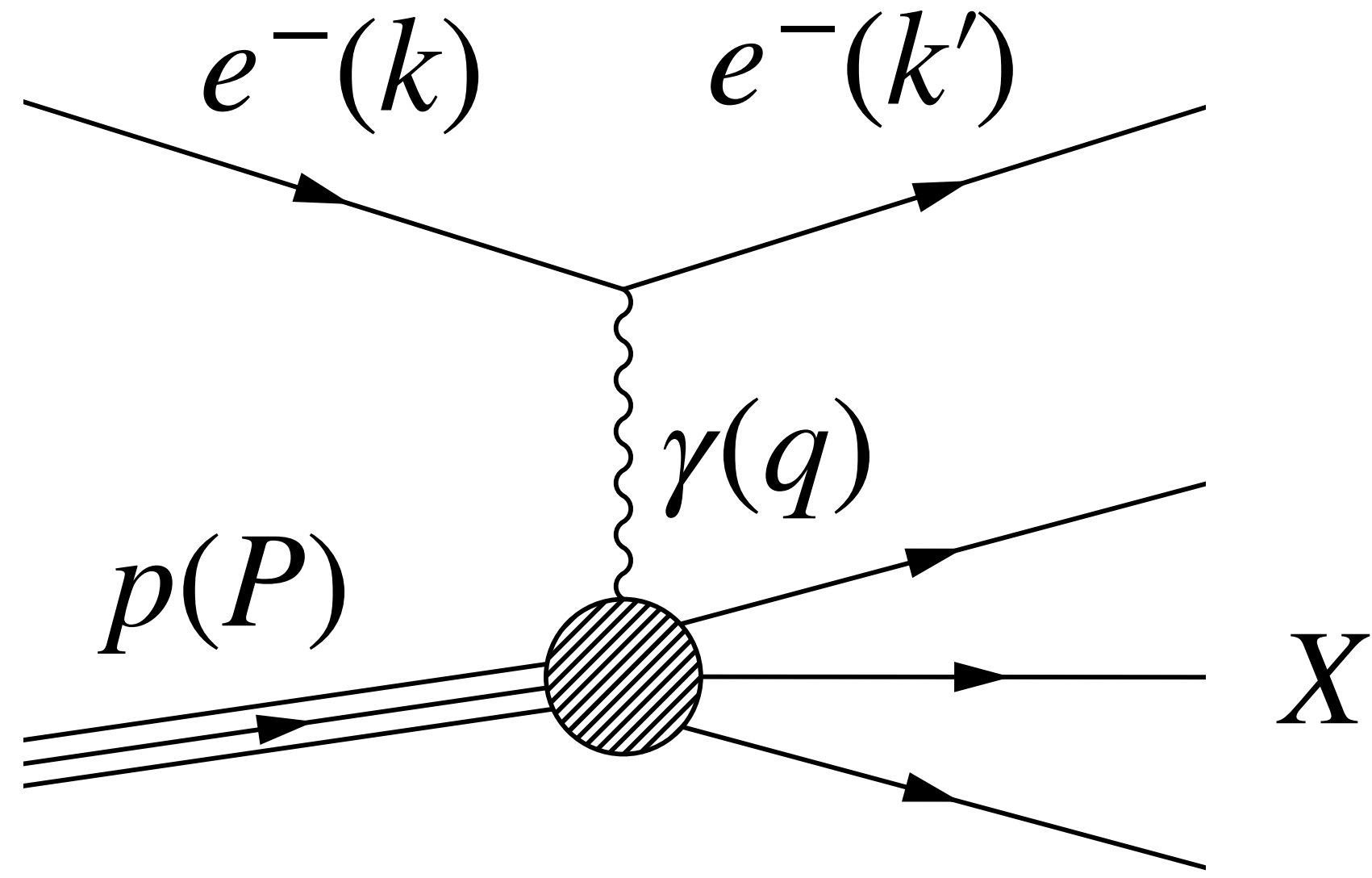

$$\frac{d\sigma}{dx dQ^2} = \frac{2\pi\alpha^2}{xyQ^4} \left[(1 + (1 - y)^2) F_2 - y^2 F_L \right]$$

$$F_2 = x \sum_q e_q^2 (q + \bar{q})$$

- Longitudinal momentum fraction
- Quark-parton model
→ PDFs depend only on x (scaling)
- Quantum chromodynamics
→ Q^2 dependence (scaling violation)

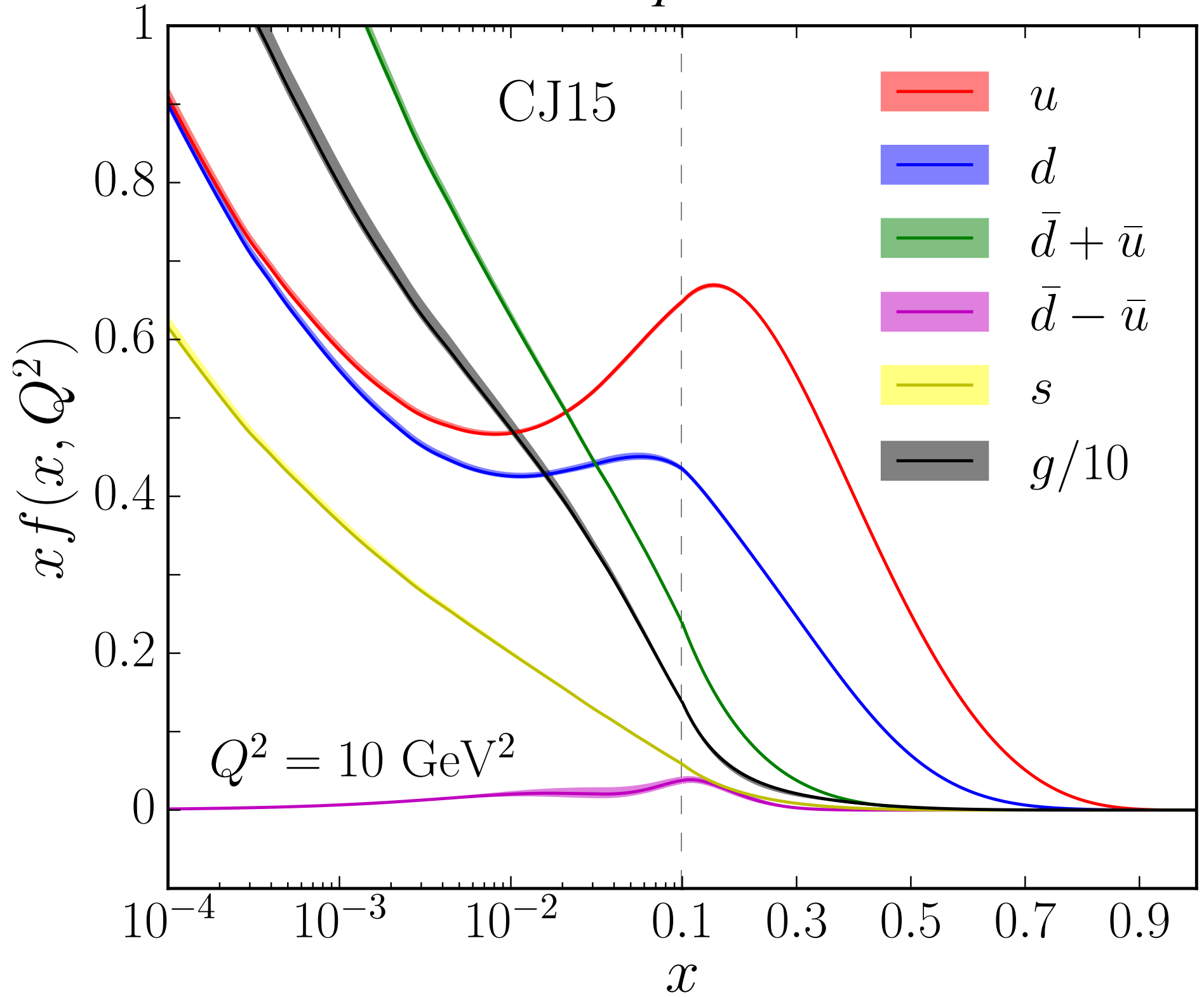

HERA taught us most of what we know about the proton



- First (and to date, only) $e^{\pm}p$ collider operated 1992-2007
- \sqrt{s} up to 320 GeV \rightarrow fixed-target equivalent to *tens of TeV* electron beam

HERA taught us most of what we know about the proton

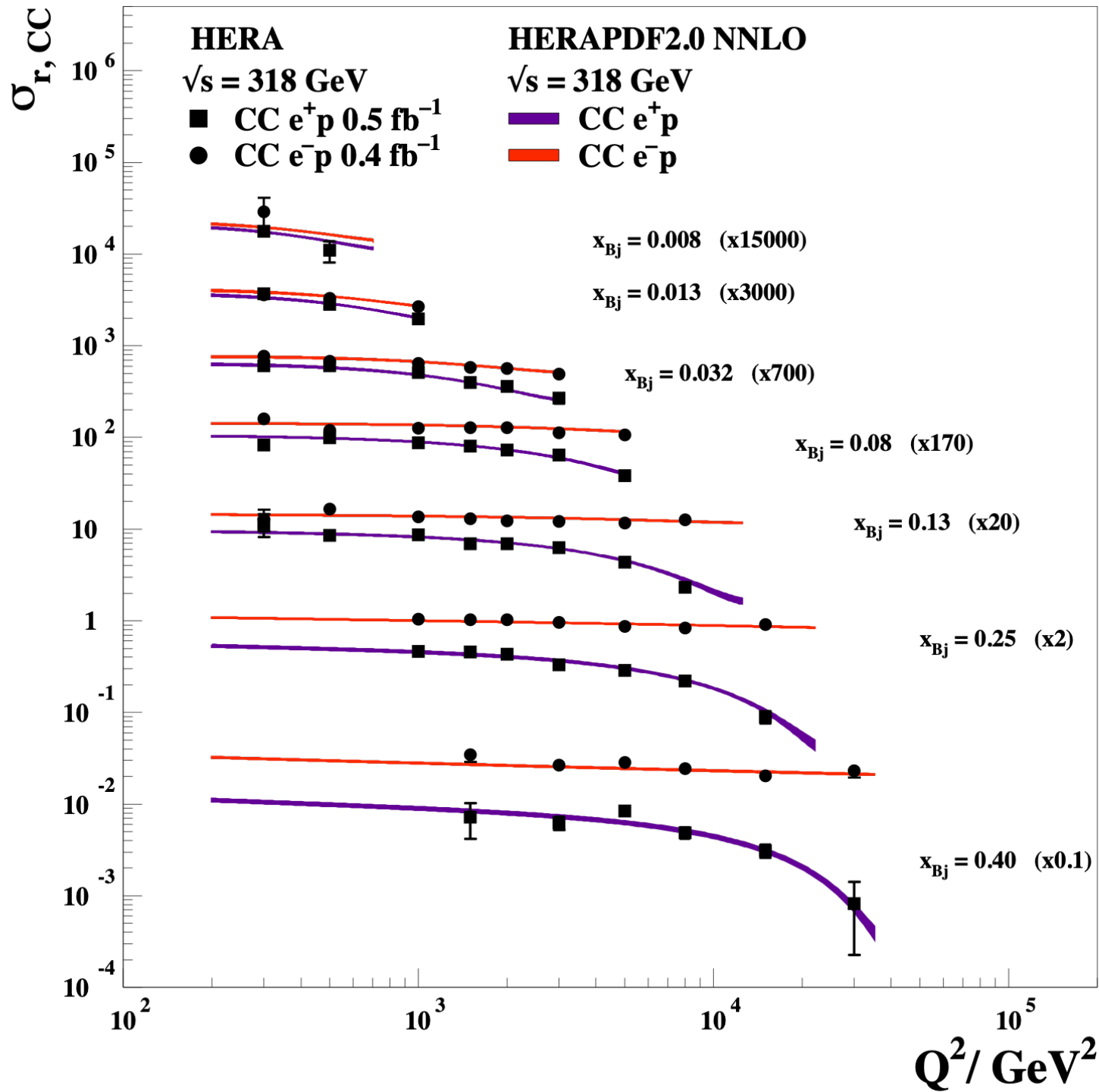
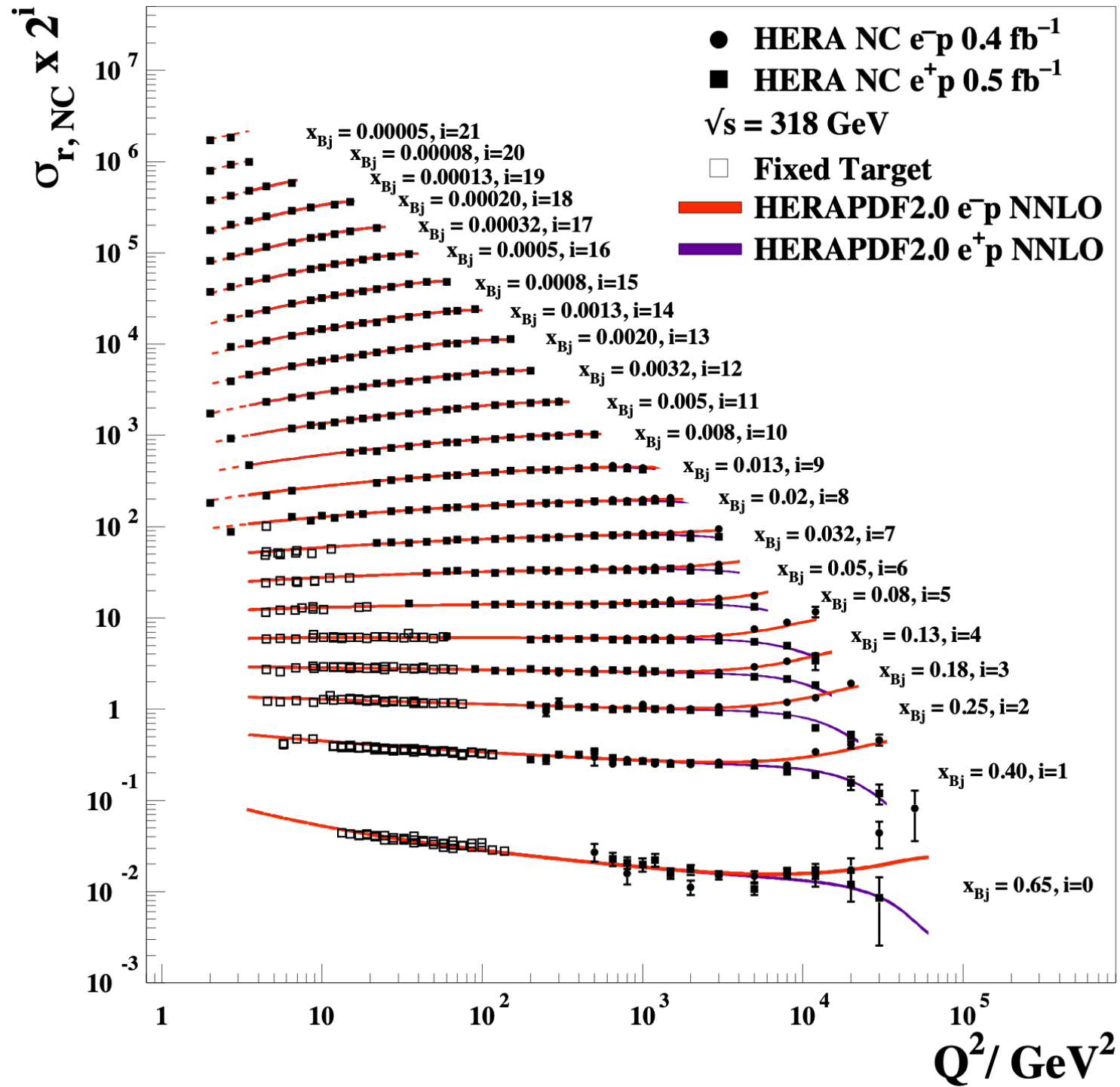

- First (and to date, only) $e^\pm p$ collider operated 1992-2007
- \sqrt{s} up to 320 GeV \rightarrow fixed-target equivalent to *tens of TeV* electron beam
- High precision, systematic study of proton structure

HERA taught us most of what we know about the proton

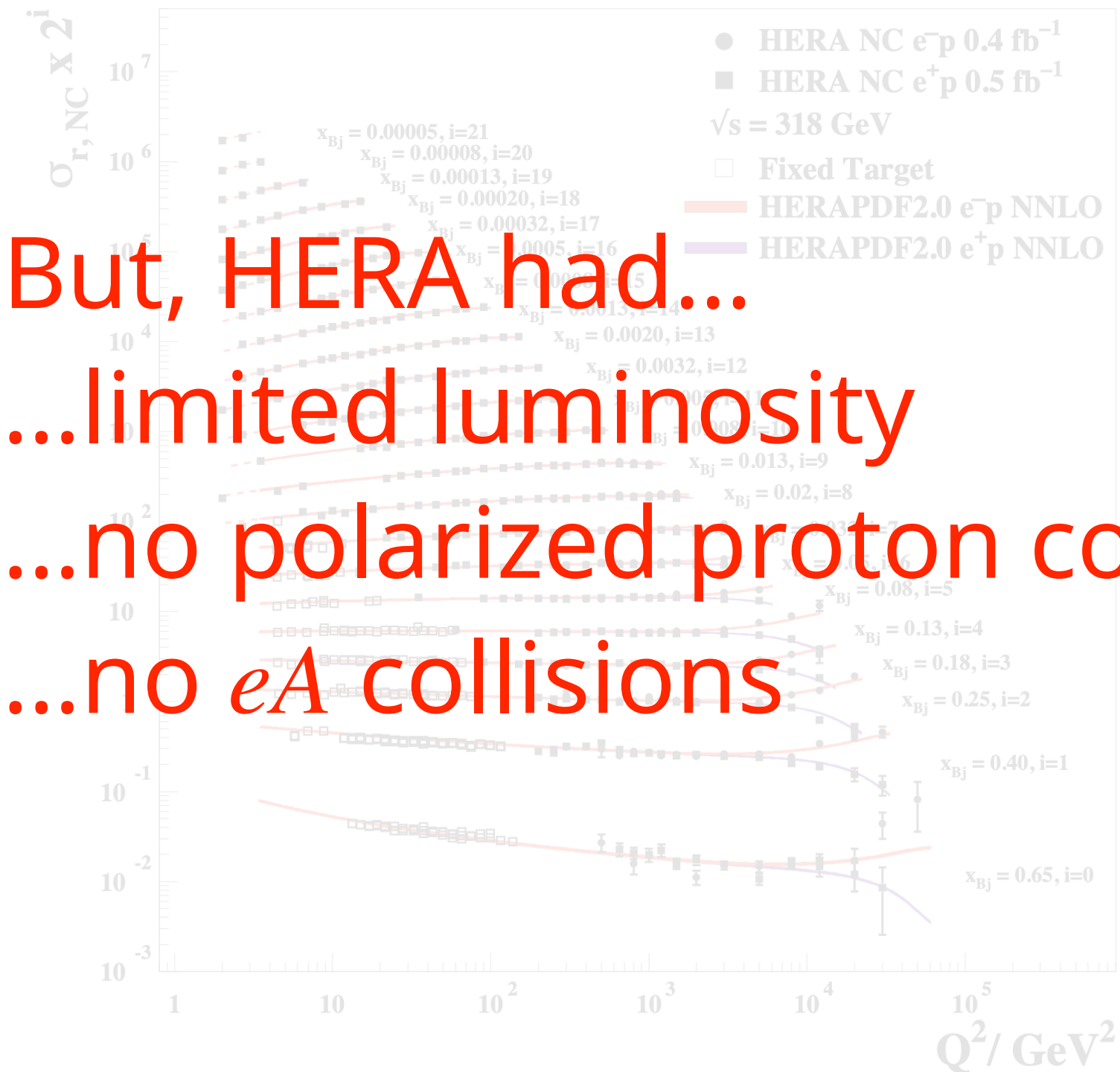

But, HERA had...
 ...limited luminosity
 ...no polarized proton collisions
 ...no eA collisions

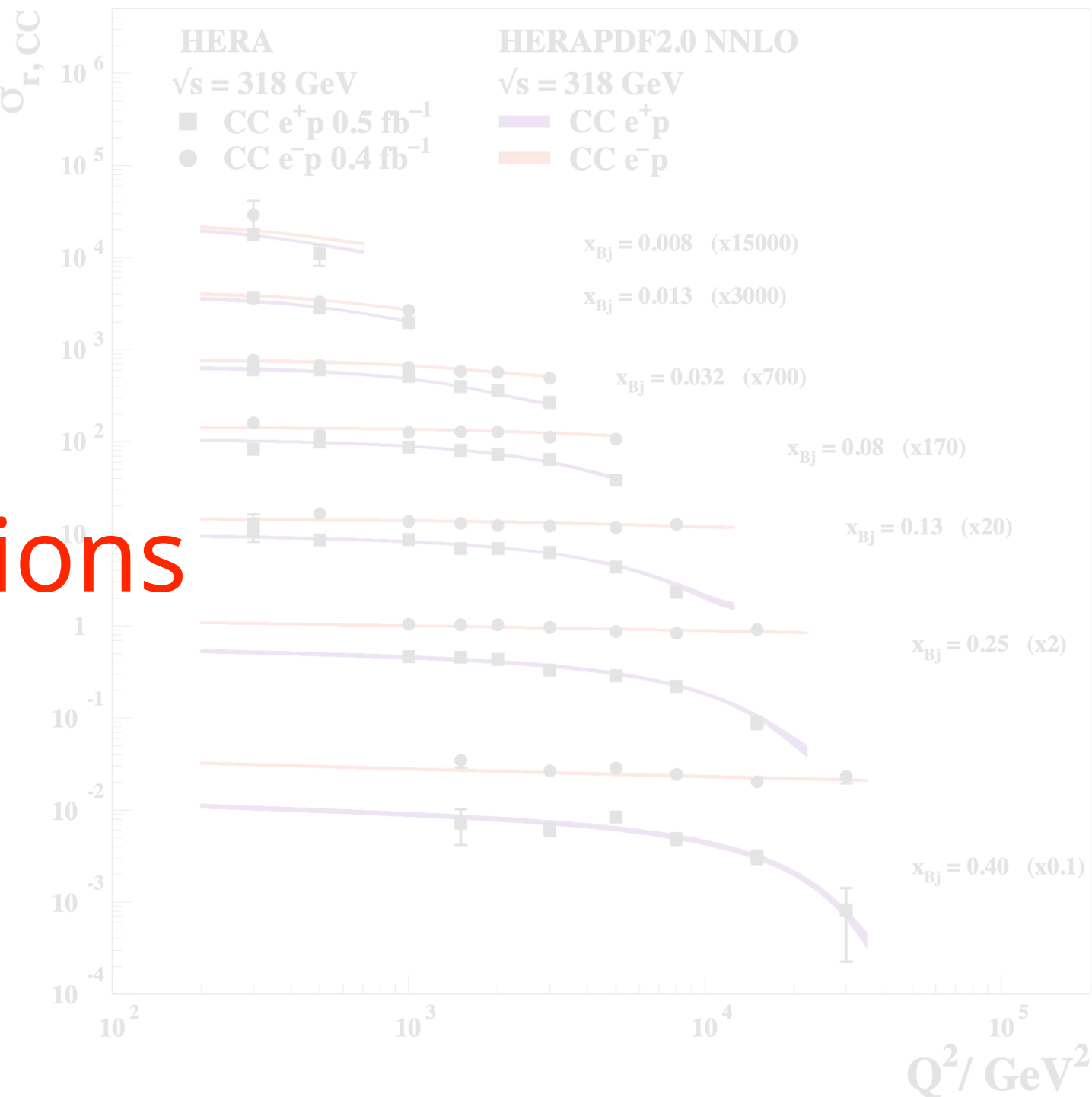

- First (and to date, only) $e^\pm p$ collider operated 1992-2007
- \sqrt{s} up to 320 GeV \rightarrow fixed-target equivalent to *tens of TeV* electron beam
- High precision, systematic study of proton structure

The electron-ion collider (EIC)

- Next-generation QCD facility to be constructed at Brookhaven National Lab
- Fully polarized ep , and eA collisions
- $20 < \sqrt{s} < 140$ GeV
- High luminosity
→ surpass total HERA dataset in first year of running

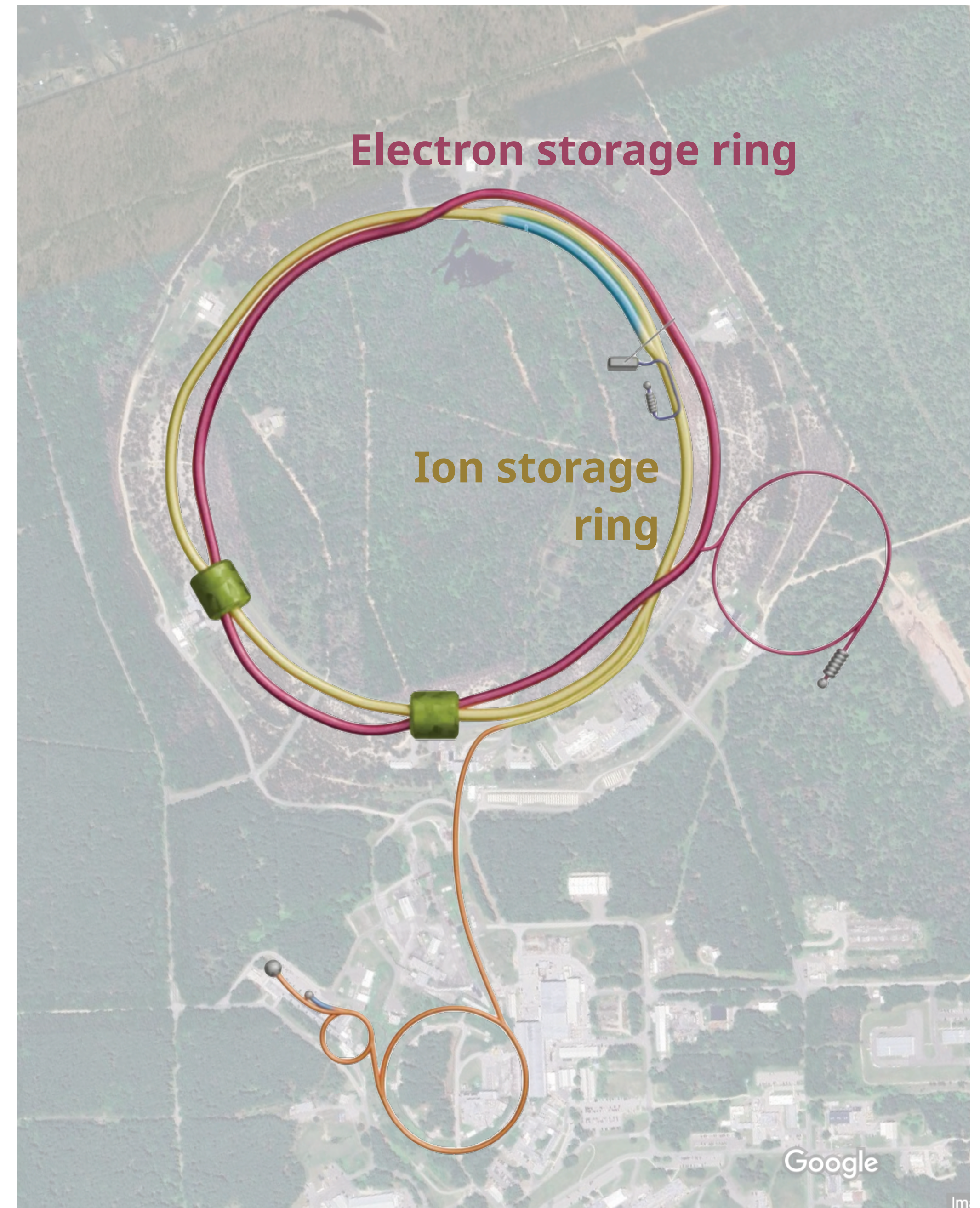

The electron-ion collider (EIC)

- Next-generation QCD facility to be constructed at Brookhaven National Lab
- Fully polarized ep , and eA collisions
- $20 < \sqrt{s} < 140$ GeV
- High luminosity
→ surpass total HERA dataset in first year of running
- ePIC detector under development
→ “Day 1” detector designed to deliver full EIC science program

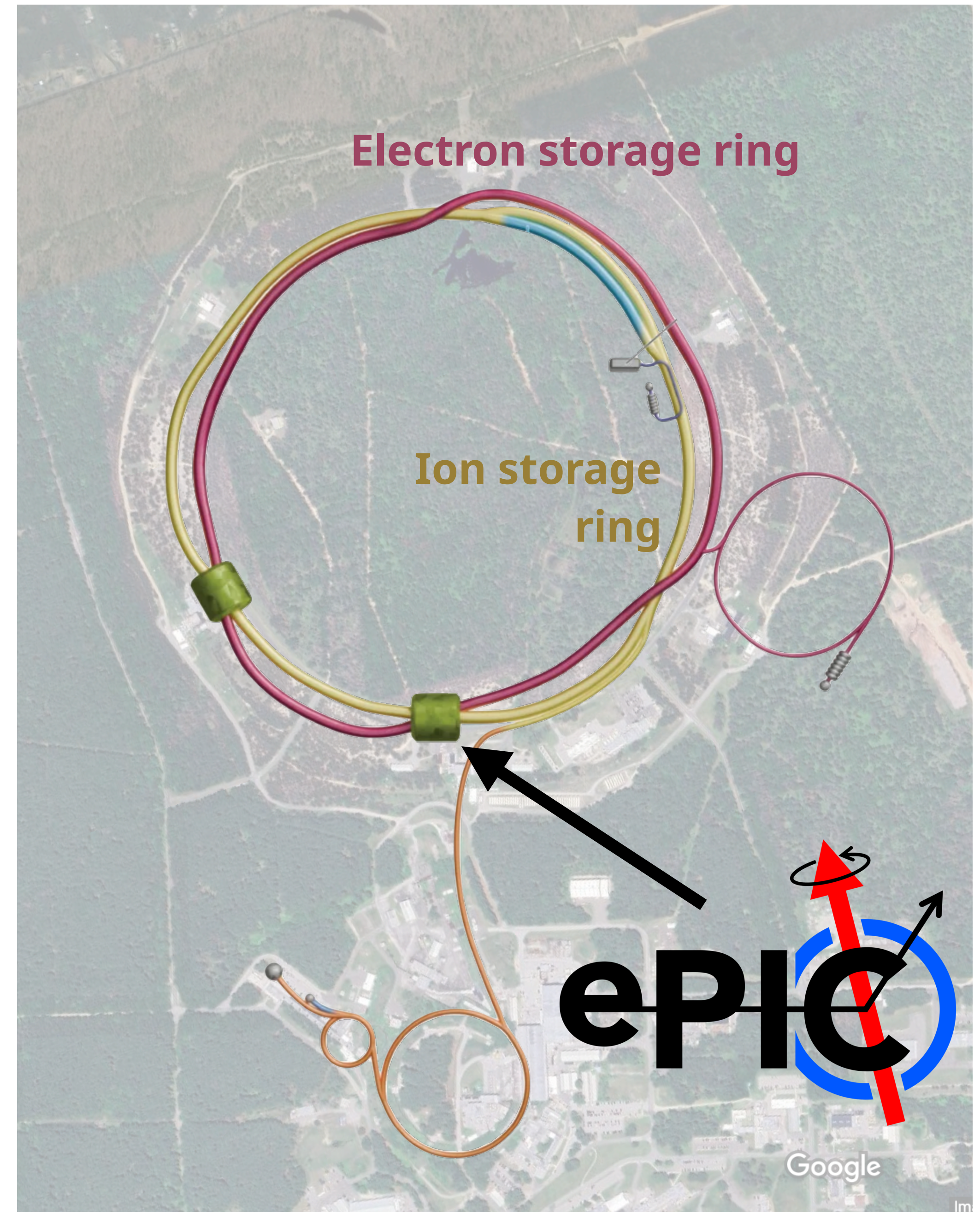

The collaboration (founded 2022)

>1100 members

181 institutions in 25 countries

CERN-recognized experiment

Goal: carry out EIC science mission through realization of the ePIC detector

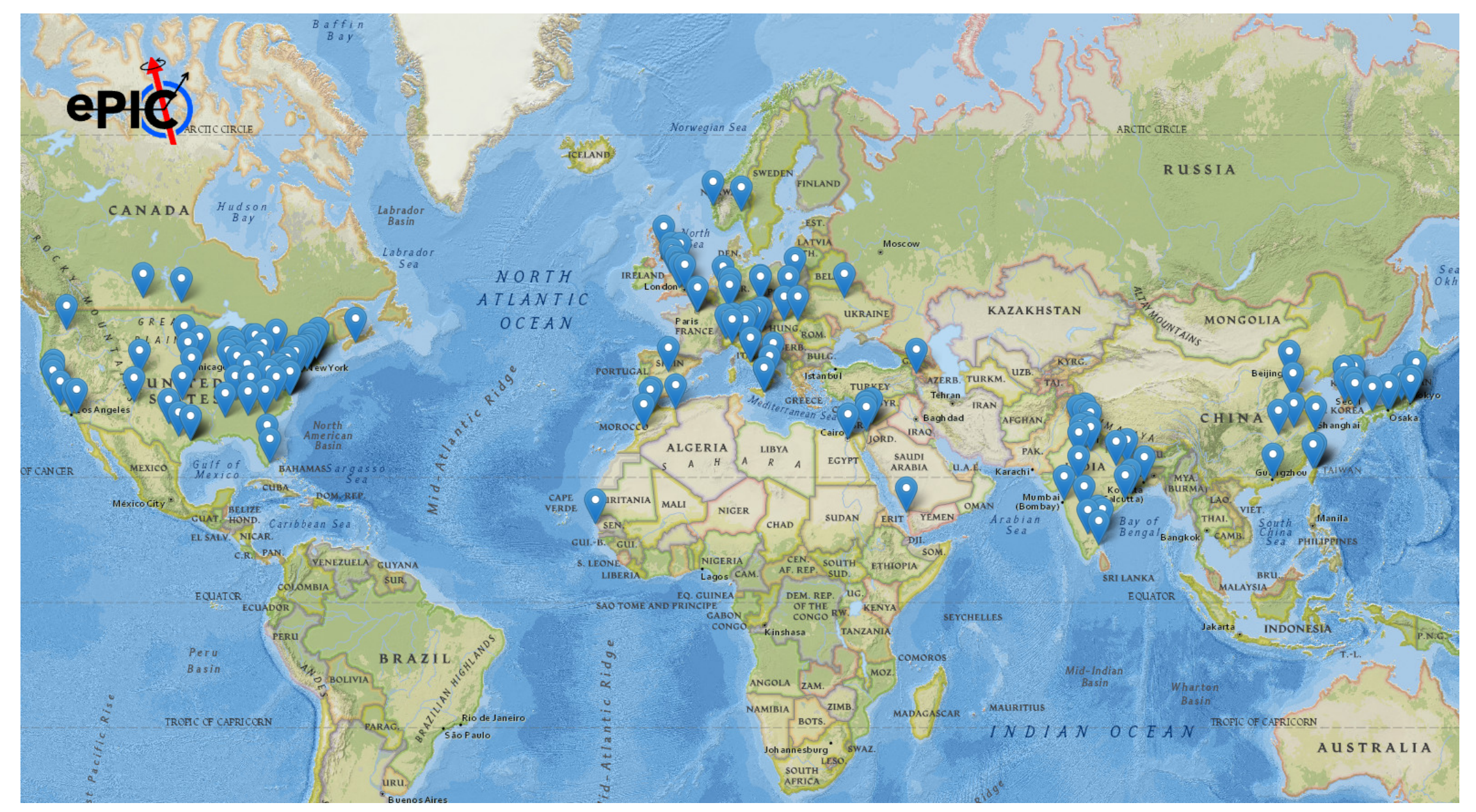

EIC physics missions



Origin of nucleon
mass & spin



EIC physics missions



Origin of nucleon
mass & spin

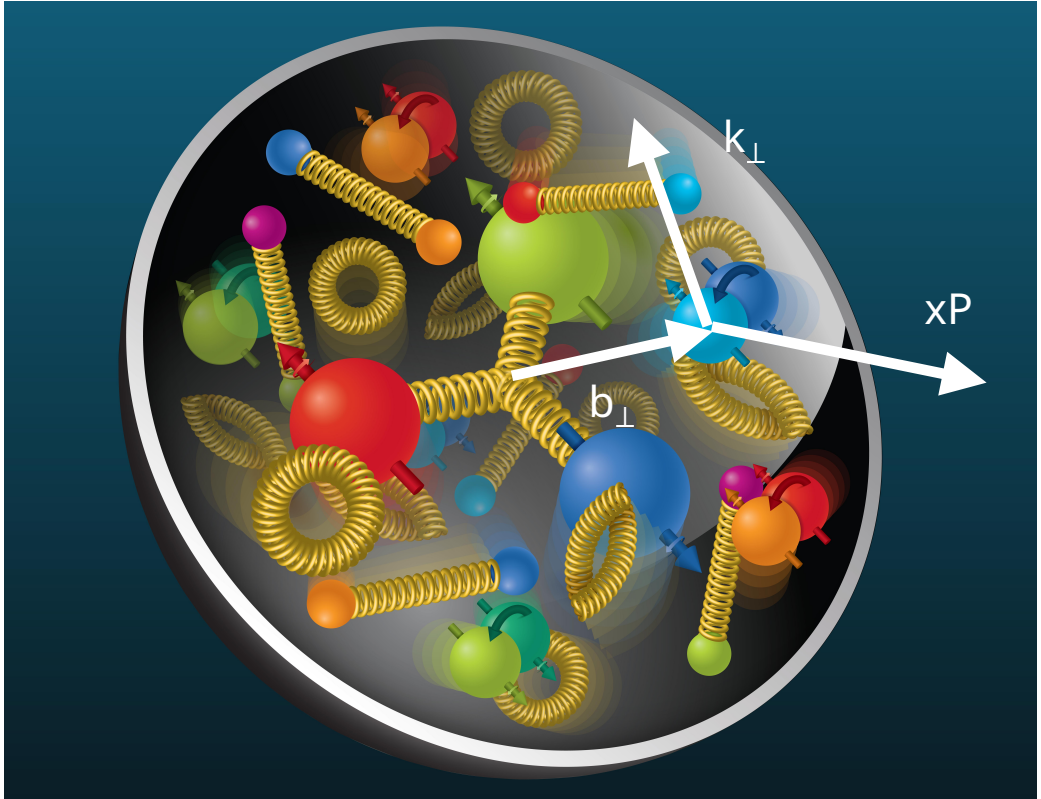

3D nucleon structure

Distribution in
space & momentum



EIC physics missions



Origin of nucleon
mass & spin

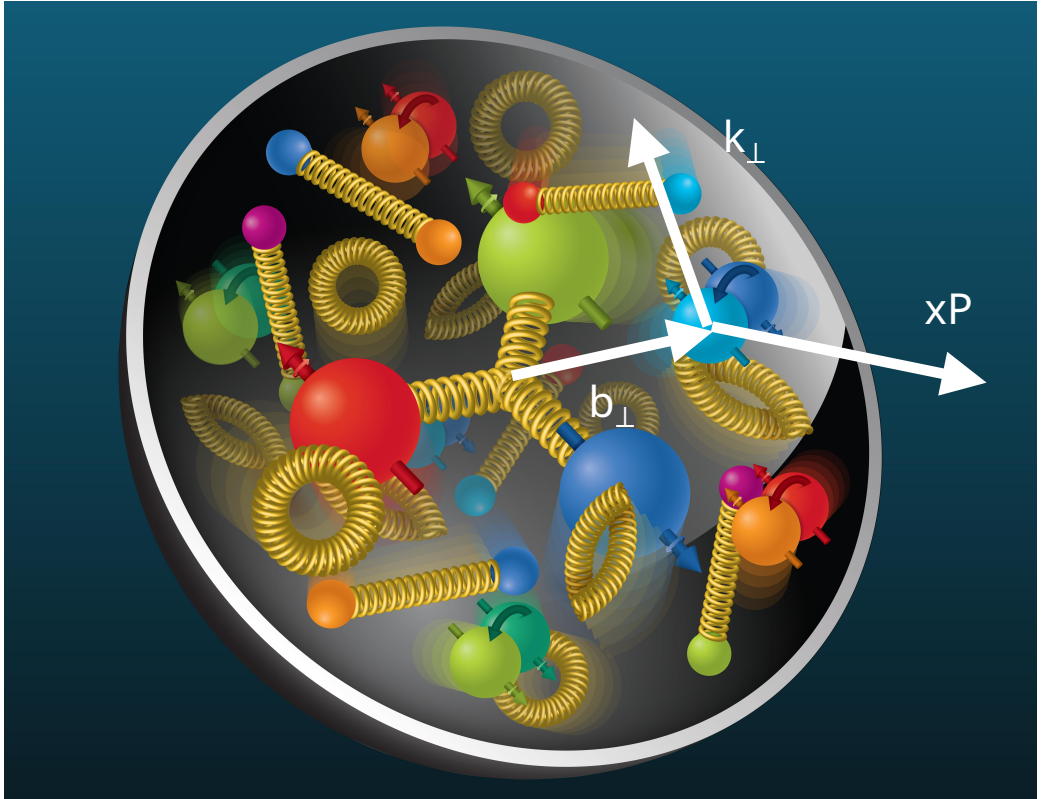

3D nucleon structure

Distribution in
space & momentum

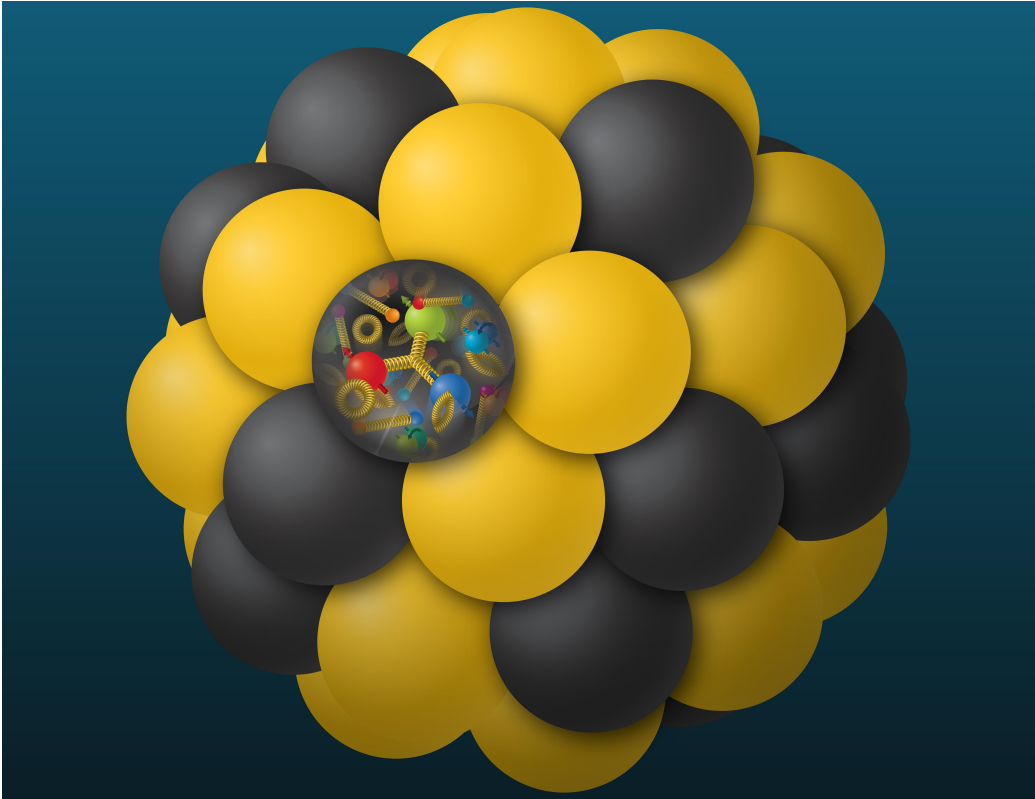

How do quarks and
gluons interact in the
nuclear medium?

EIC physics missions



Origin of nucleon
mass & spin

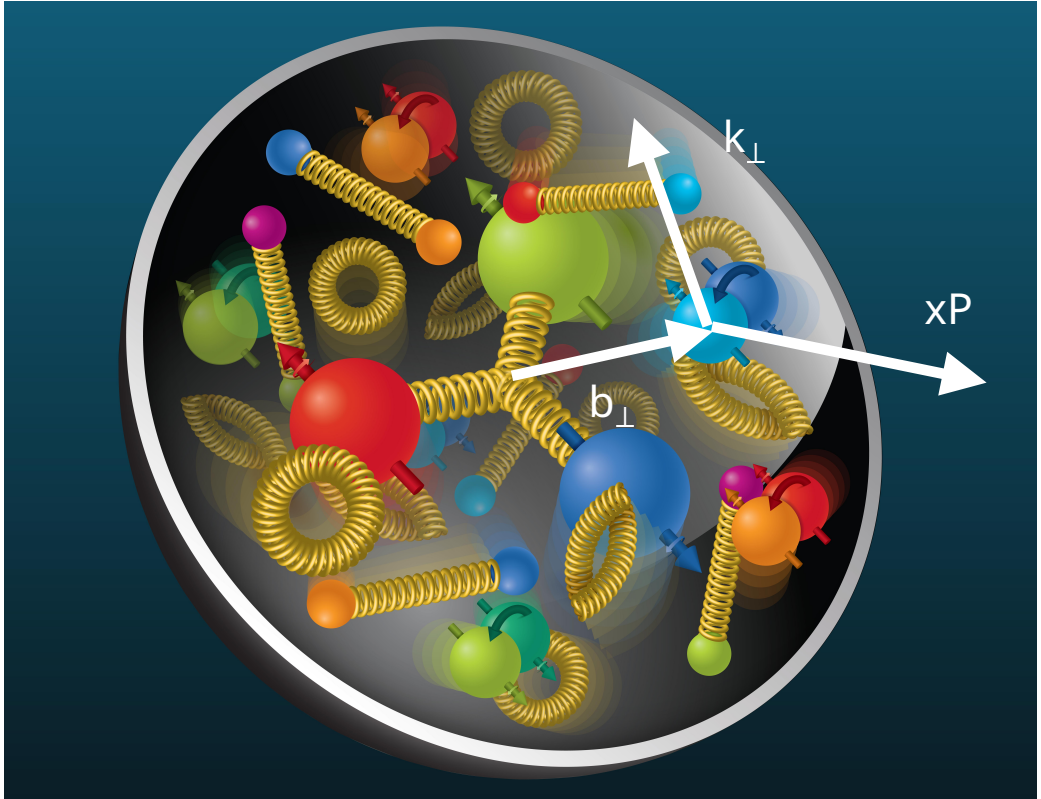

3D nucleon structure
Distribution in
space & momentum

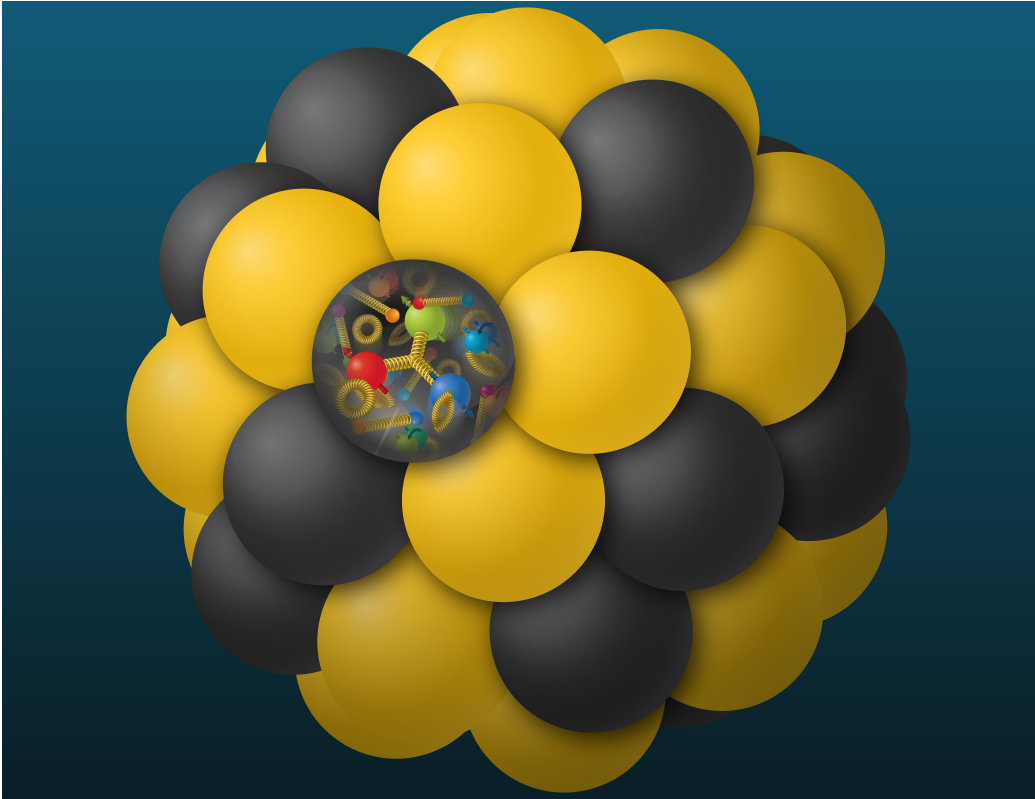

How do quarks and
gluons interact in the
nuclear medium?

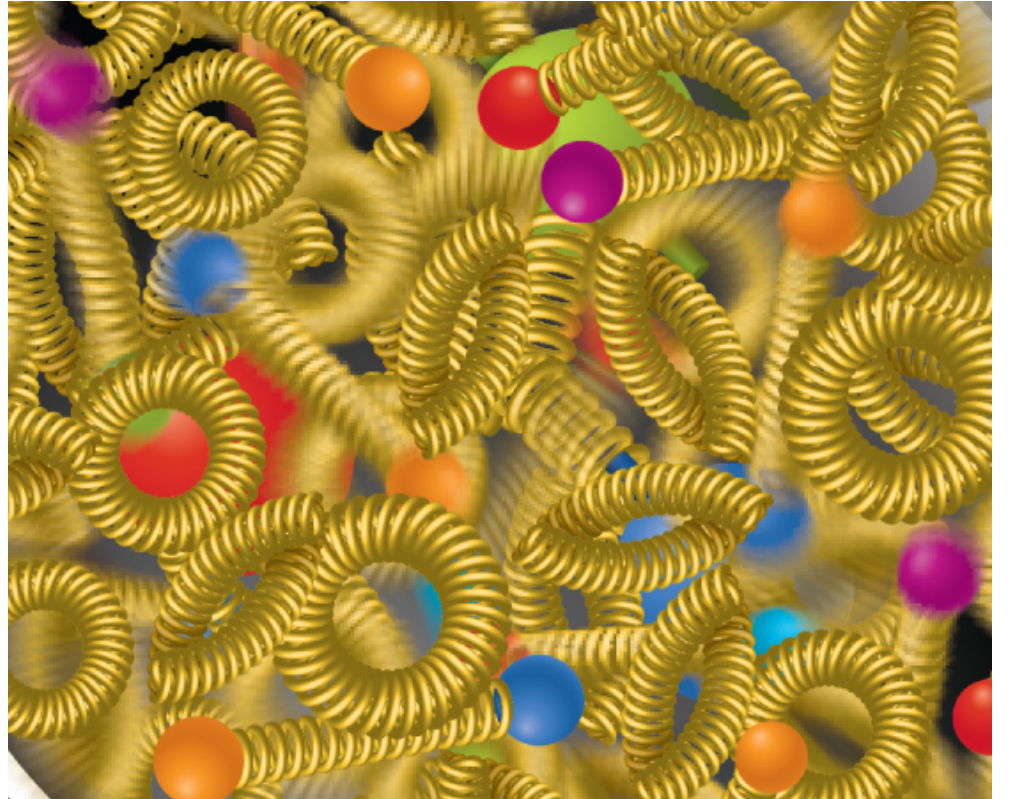

Properties of dense
gluon systems...
*How many gluons
fit in the proton?*

Physics-driven detector requirements

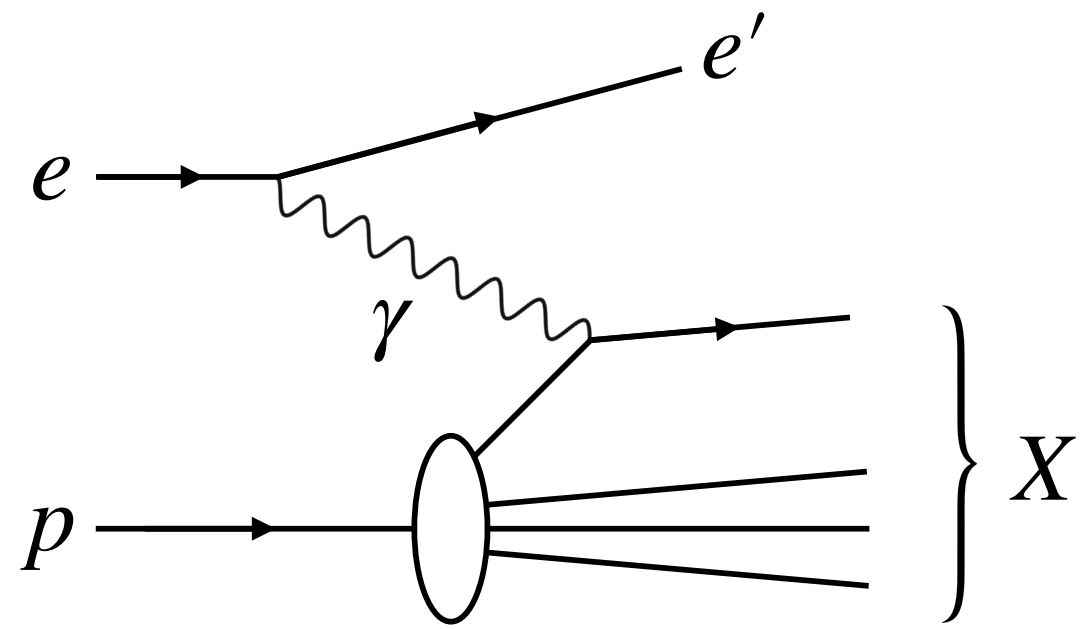

Inclusive DIS
High-resolution
binning in x, Q^2

- Large acceptance to maximize phase space
- High-resolution EM calorimetry and PID for e/π separation
- Low-mass, high-resolution tracking

Physics-driven detector requirements

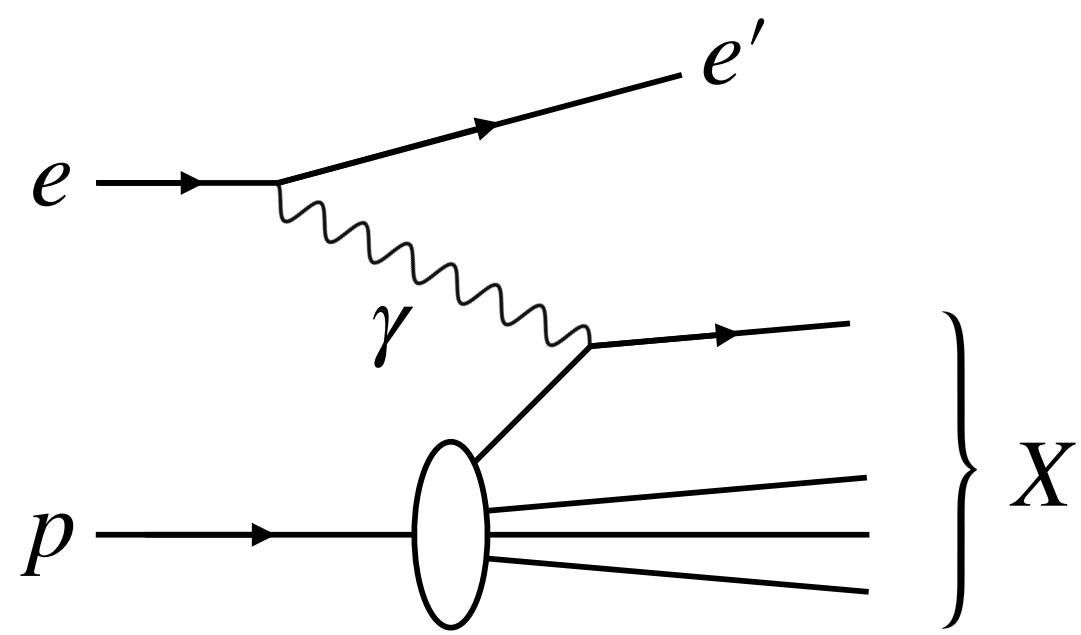

Inclusive DIS
High-resolution
binning in x, Q^2

- Large acceptance to maximize phase space
- High-resolution EM calorimetry and PID for e/π separation
- Low-mass, high-resolution tracking

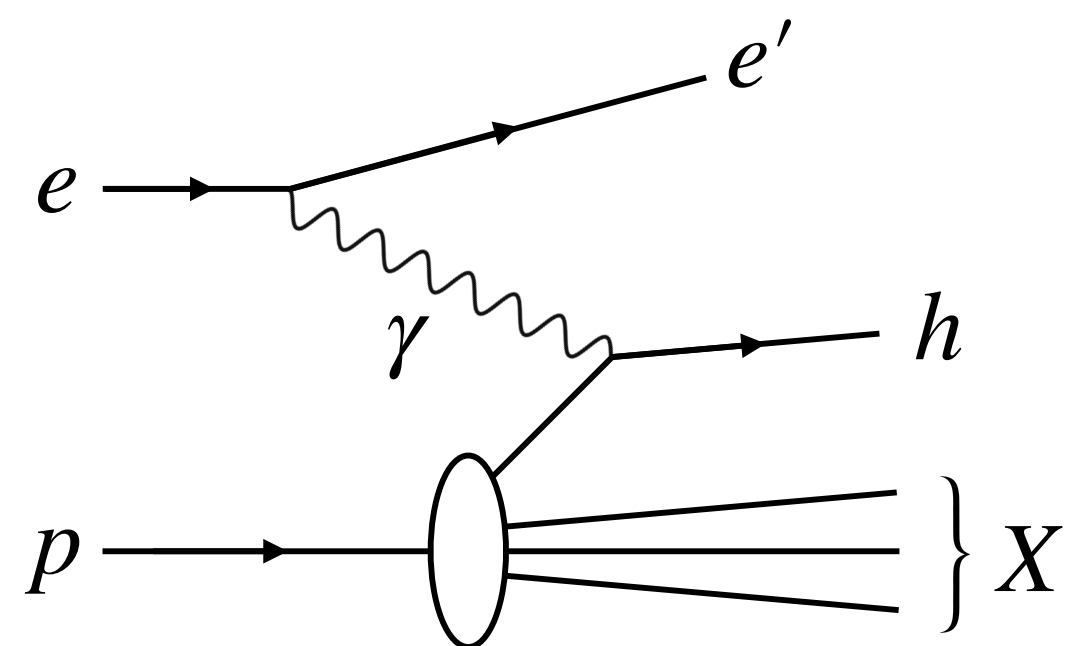

Semi-inclusive DIS
5D binning in
 x, Q^2, z, p_T, ϕ_h

- High p_T (tracking) resolution
- Extensive PID coverage for hadron ID
- Hadronic calorimetry for neutral hadron, muon ID

Physics-driven detector requirements

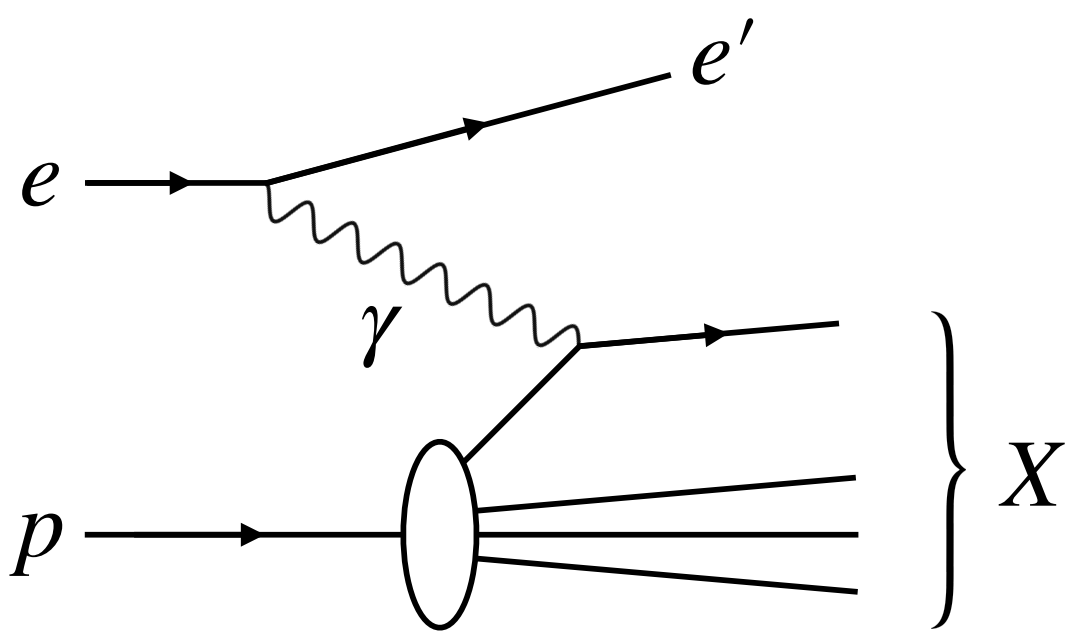

Inclusive DIS
High-resolution binning in x, Q^2

- Large acceptance to maximize phase space
- High-resolution EM calorimetry and PID for e/π separation
- Low-mass, high-resolution tracking

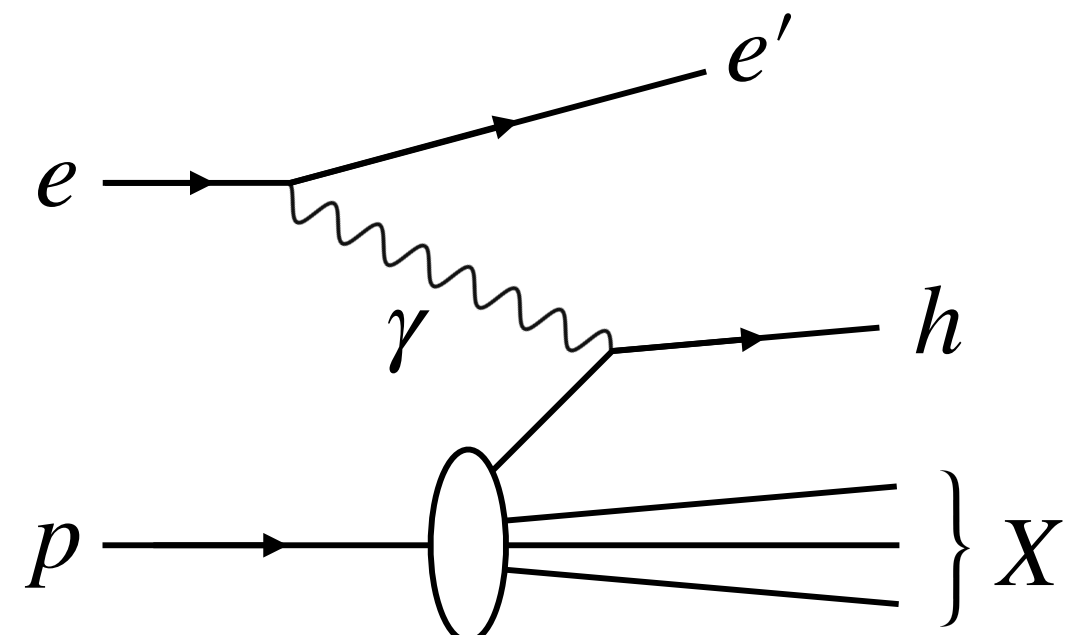

Semi-inclusive DIS
5D binning in x, Q^2, z, p_T, ϕ_h

- High p_T (tracking) resolution
- Extensive PID coverage for hadron ID
- Hadronic calorimetry for neutral hadron, muon ID

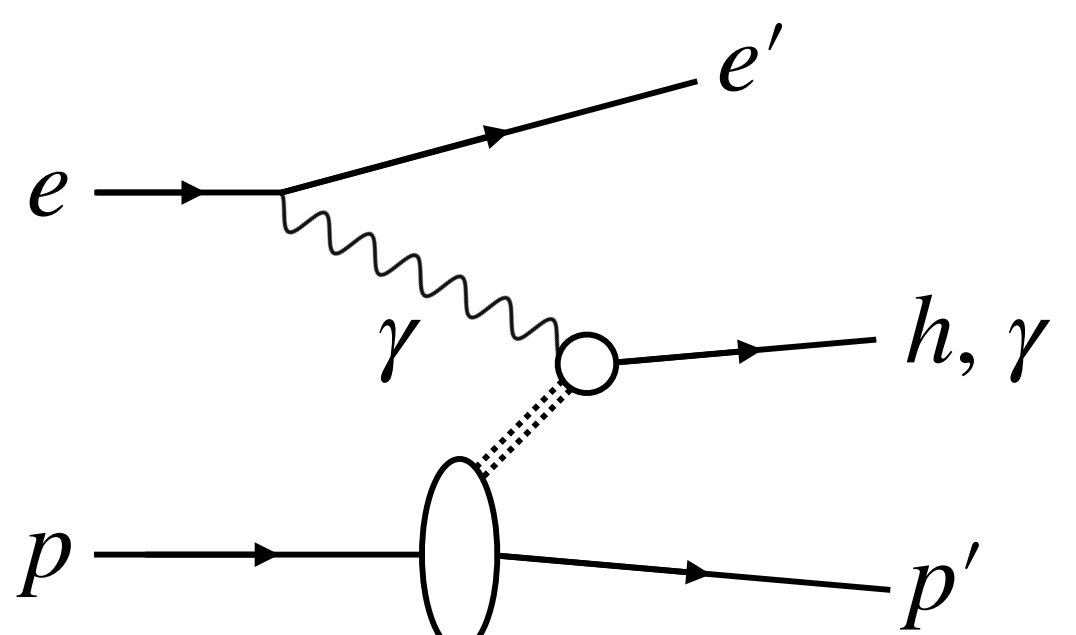

Exclusive processes
4D binning in x, Q^2, t, ϕ_h

- Small-angle acceptance and beam line instrumentation
- Excellent vertex resolution
- EM calorimetry for γ/π separation

ePIC detector: a schematic view

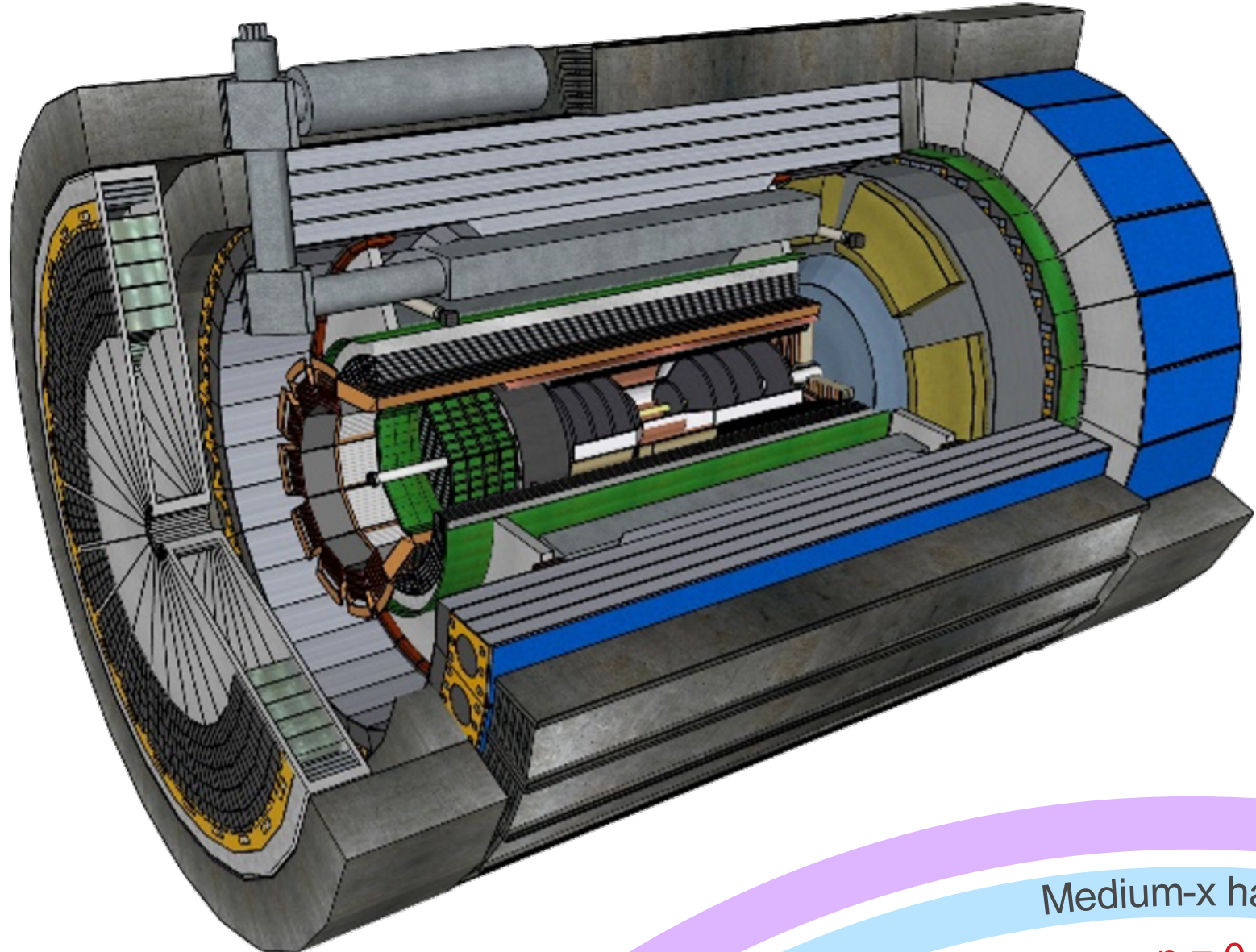

- Central detector $|\eta| < 3.5$: tracking, PID, electromagnetic + hadronic calorimetry
- Asymmetric design reflecting different beam species, energies

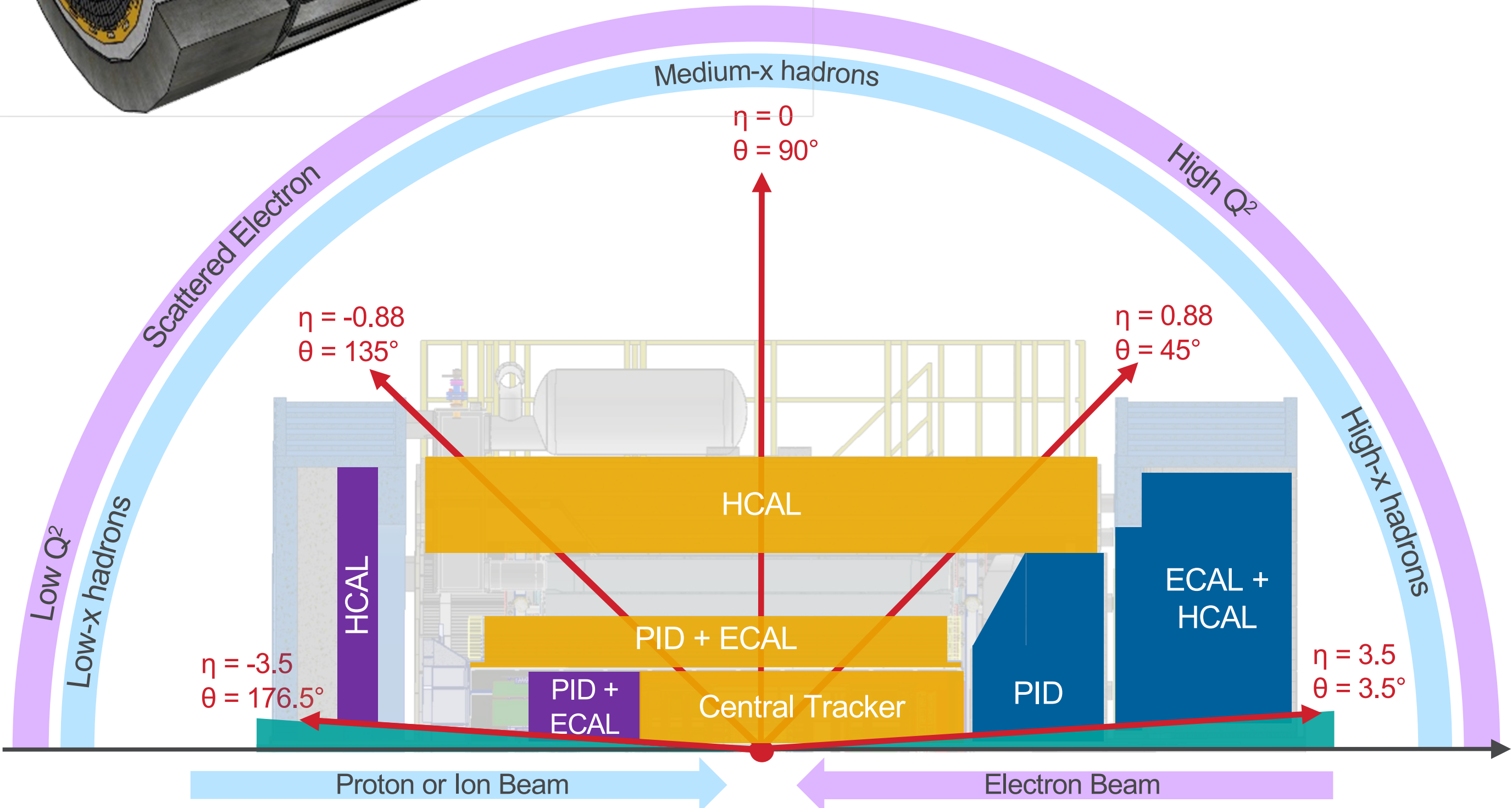

ePIC detector: a schematic view

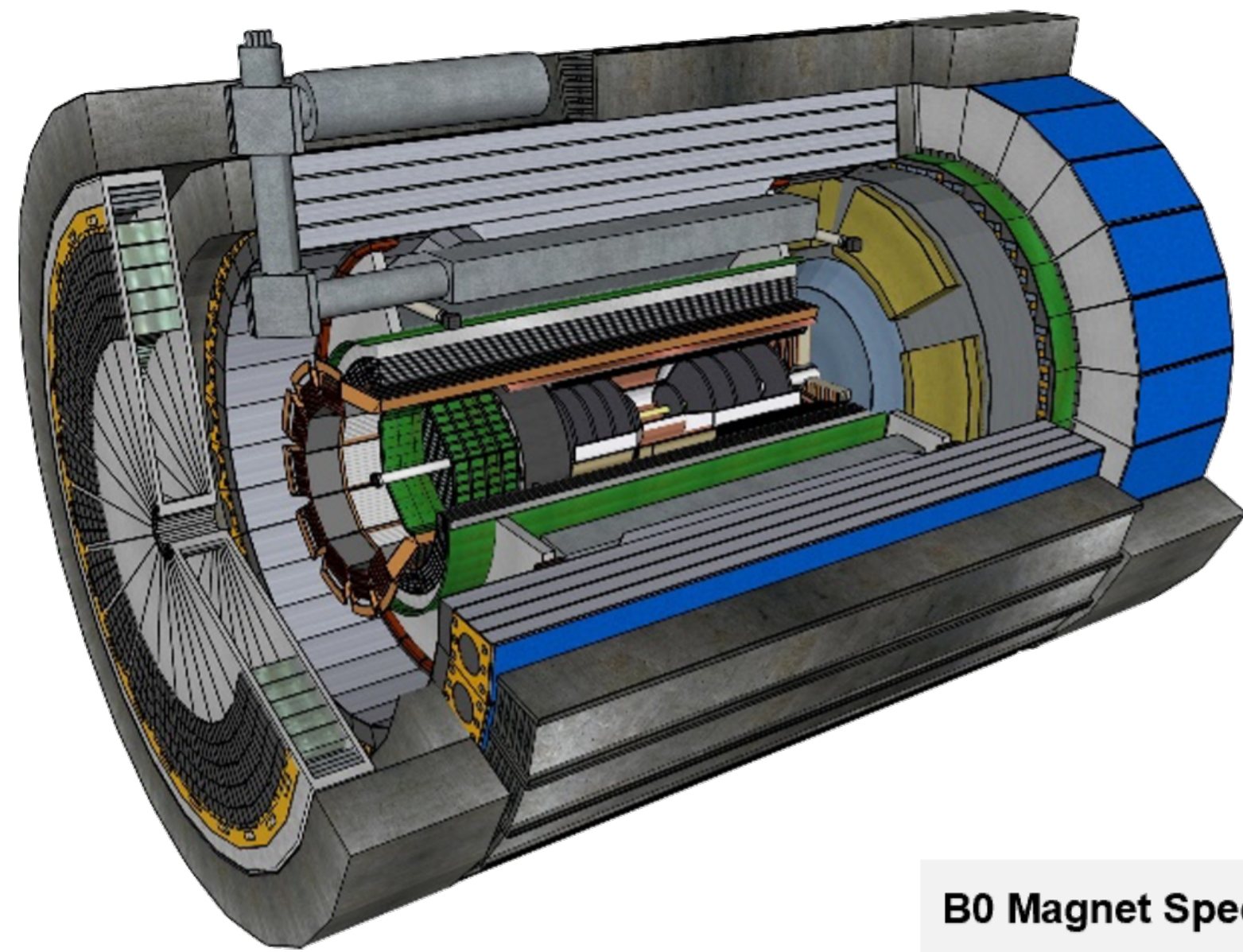

- Central detector $|\eta| < 3.5$: tracking, PID, electromagnetic + hadronic calorimetry
- Asymmetric design reflecting different beam species, energies

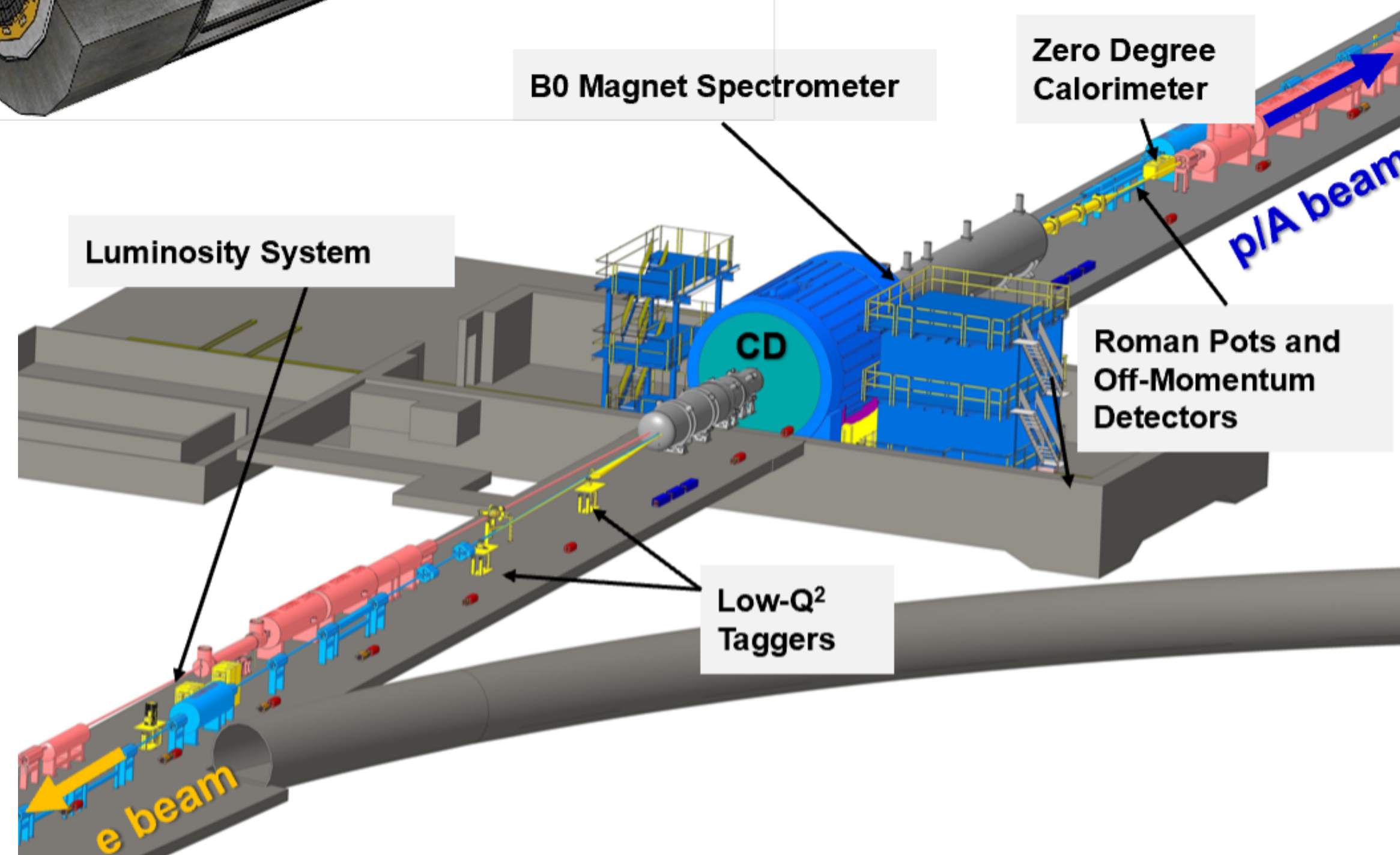

- Extensively instrumented forward/backward beam line
- Full detector ~ 90 m long
→ careful integration with IR, accelerator

ePIC detector capabilities

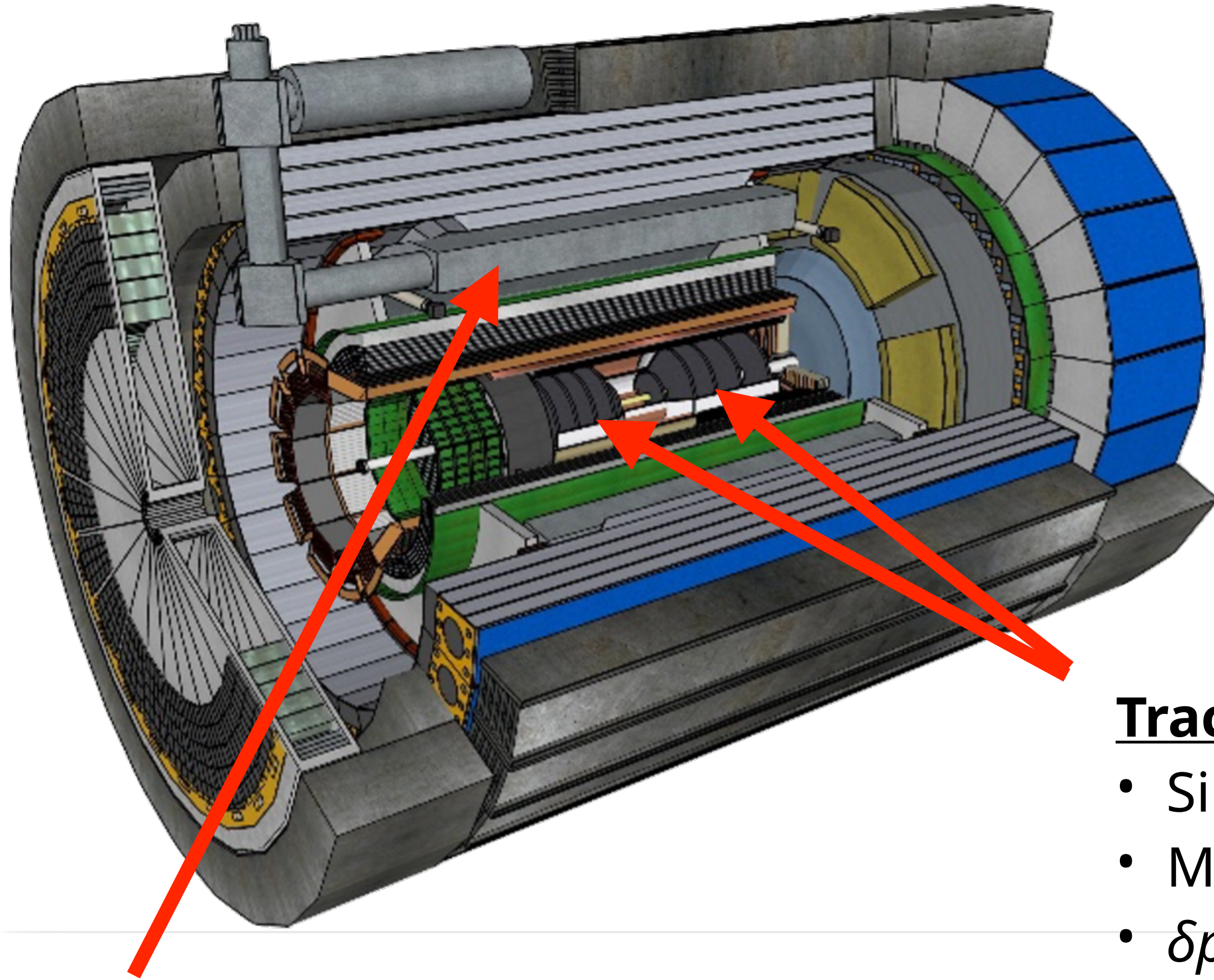

Magnet

- 1.7 T superconducting solenoid

Tracking detectors

- Si MAPS (vertex, barrel, disks)
- MPGDs (μ RWELL, micromegas) (barrel, disks)
- $\delta p/p$ [%] = $0.05 \times p \oplus 0.5$ at mid- η
- Low material budget ($X/X_0 = 0.05$ at mid- η)

ePIC detector capabilities

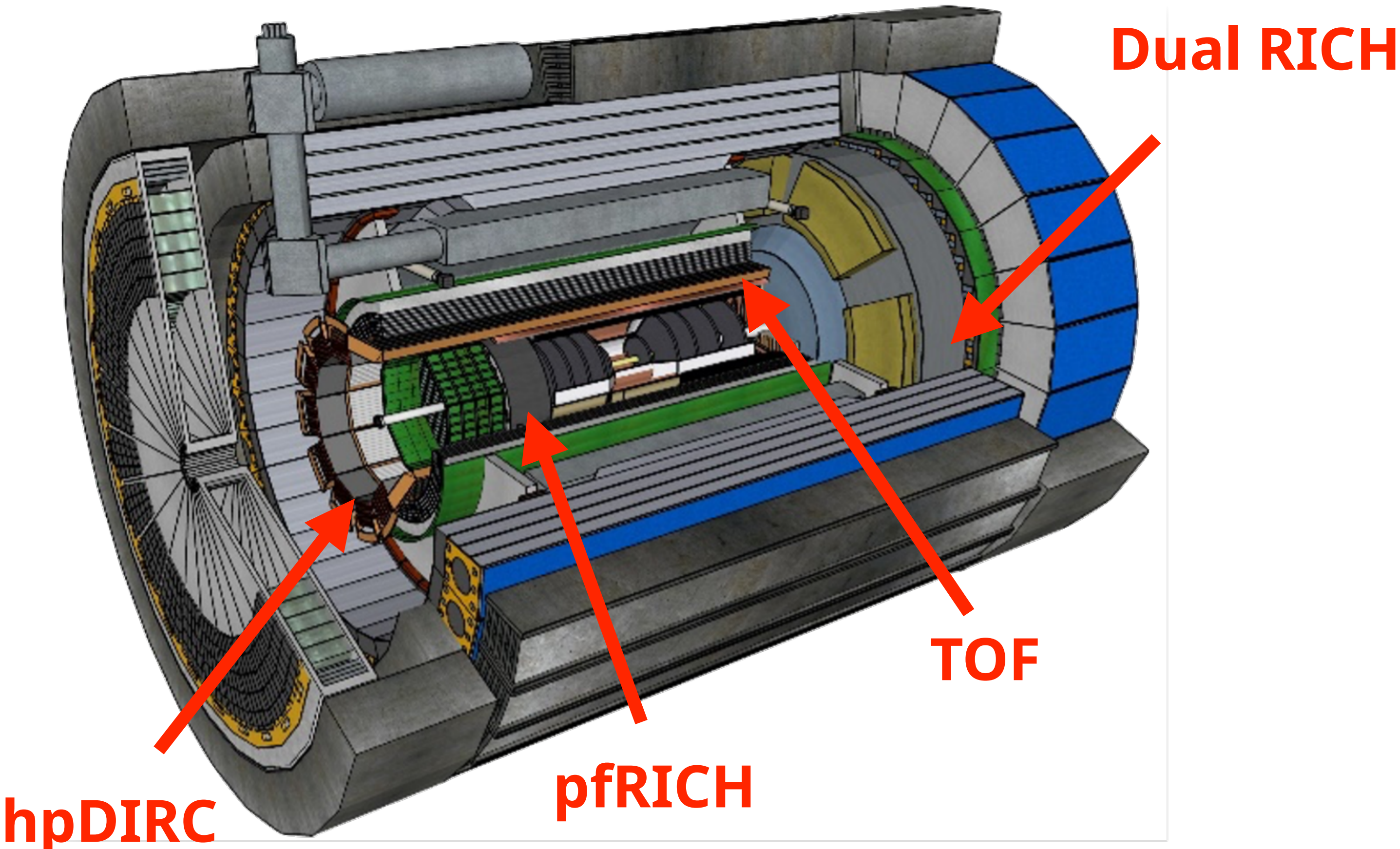

- PID**
- hpDIRC (barrel)
 - Dual RICH (forward)
 - pFRICH (backward)
 - TOF (barrel and forward)

- 3σ separation of $\pi/K/p$ across wide phase space
- Critical support to eID at low momentum

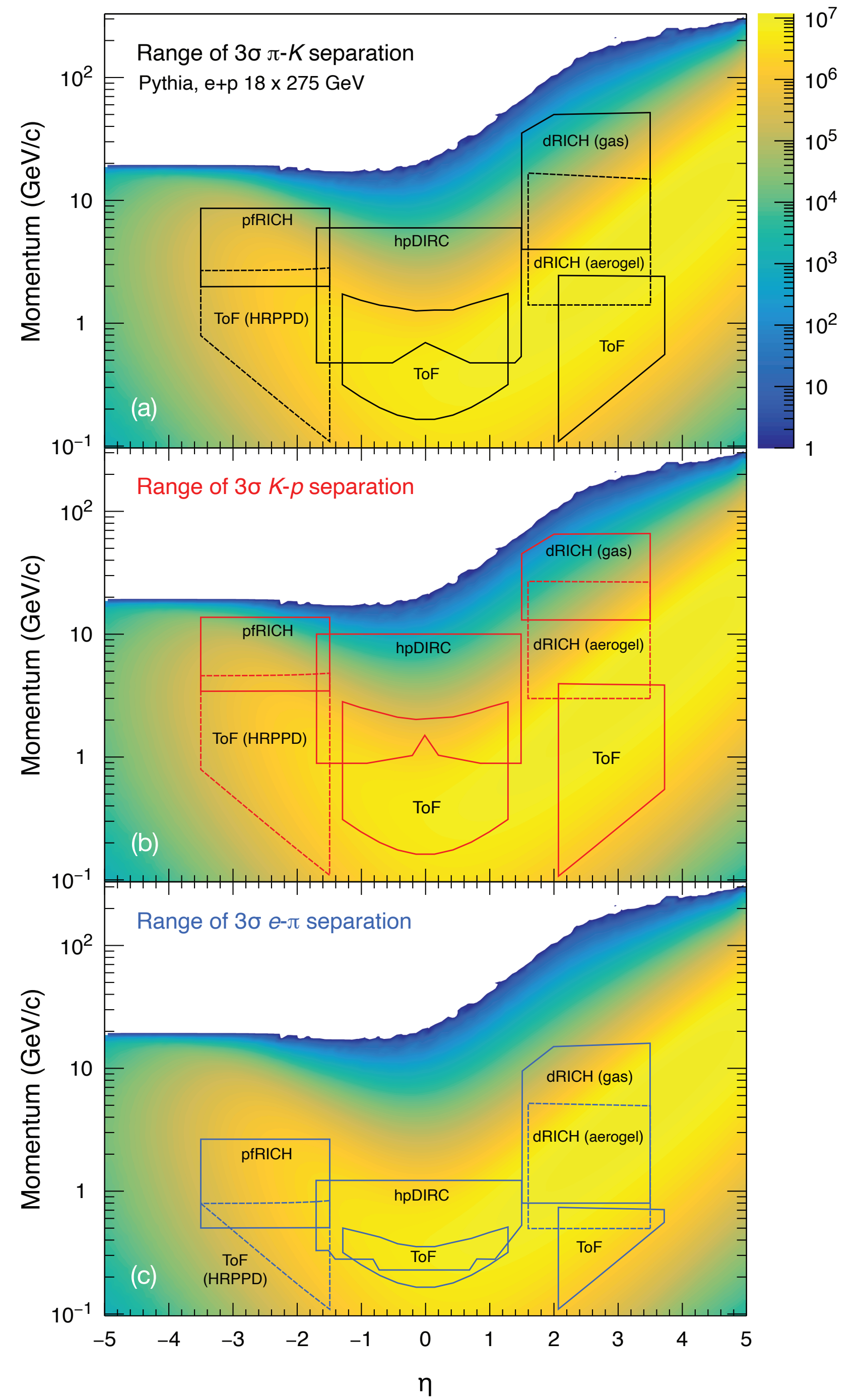

ePIC detector capabilities

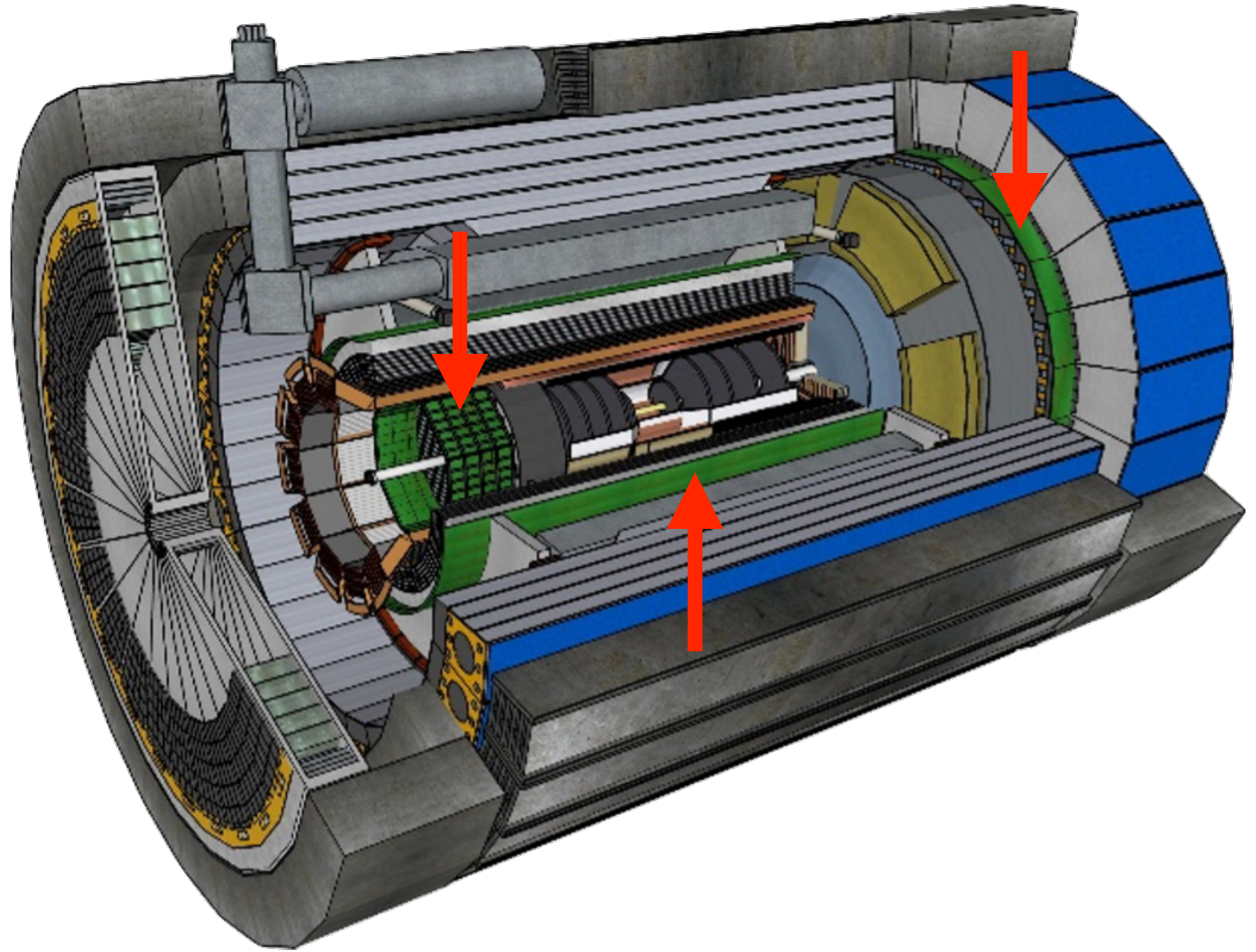

Electromagnetic calorimetry

- PbWO₄ crystals (backward): $\sigma_E/E = (2-3)\%/\sqrt{E} \oplus (1-2)\%$
- Imaging EMCAL (barrel): $\sigma_E/E = 10\%/\sqrt{E} \oplus (2-3)\%$
- W/SciFi (forward): $\sigma_E/E = 12\%/\sqrt{E} \oplus 2\%$

ePIC detector capabilities

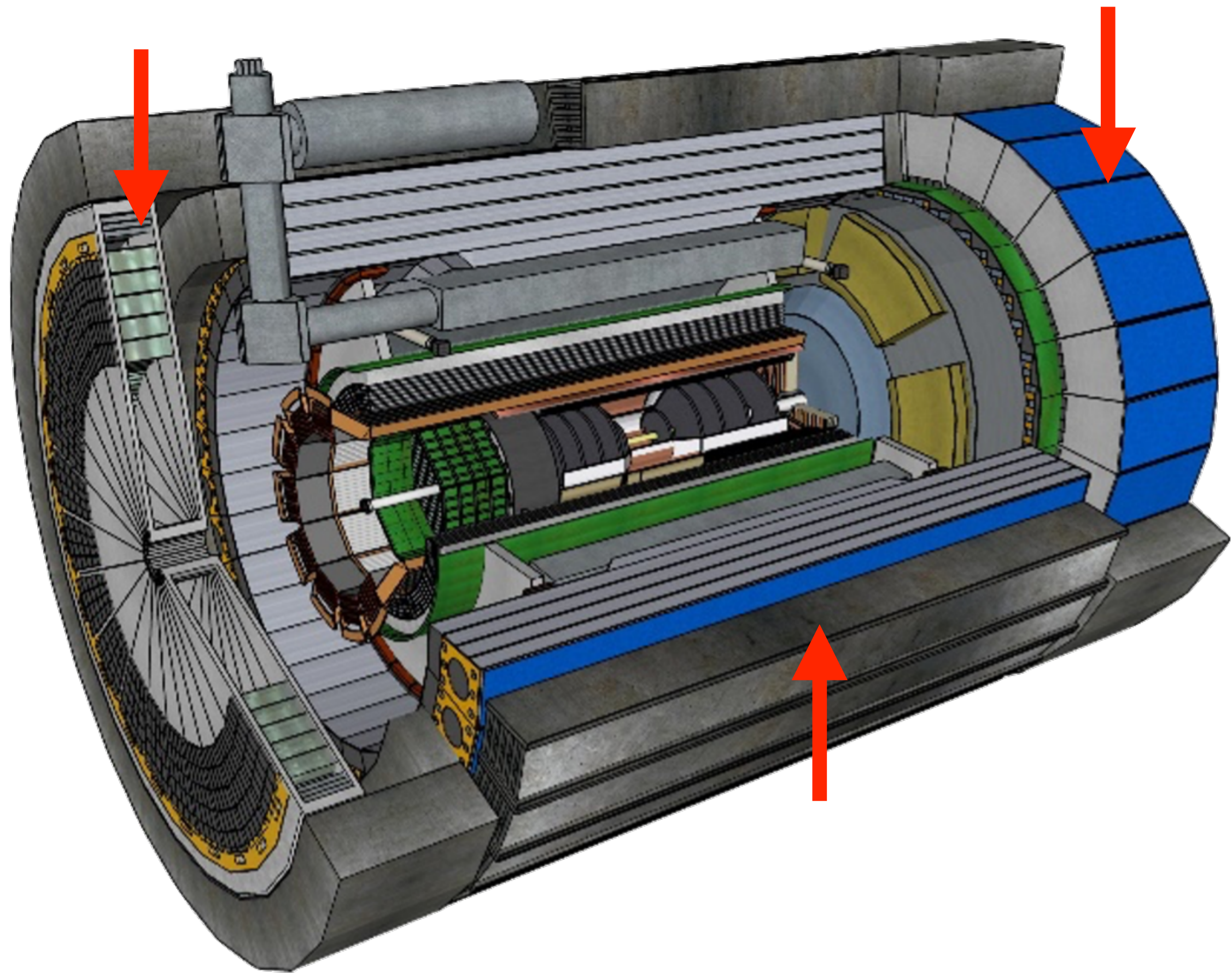

Hadronic calorimetry

- Reuse sPHENIX Steel/Sci (barrel)
- Steel/Sci (backward)
- Segmented Steel/Sci (forward) with high-granularity insert at large η
- Critical to neutral jets, kinematic reconstruction, μ ID

Electromagnetic calorimetry

- PbWO_4 crystals (backward): $\sigma_E/E = (2-3)\%/\sqrt{E} \oplus (1-2)\%$
- Imaging EMCAL (barrel): $\sigma_E/E = 10\%/\sqrt{E} \oplus (2-3)\%$
- W/SciFi (forward): $\sigma_E/E = 12\%/\sqrt{E} \oplus 2\%$

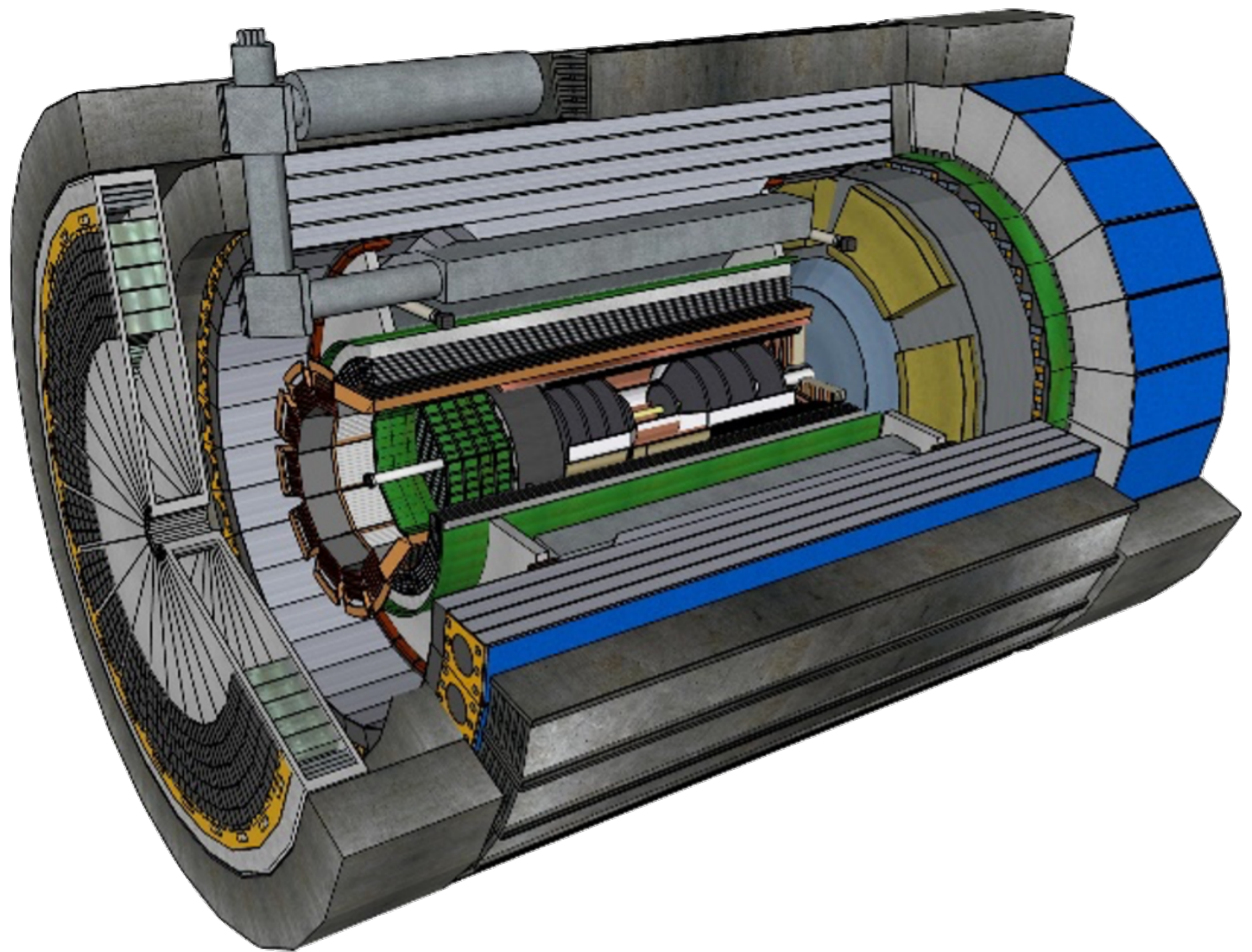

Let's do Physics!

Disclaimer: this will cover some of the highlights, but due to time constraints can not cover full science program!

Why do we need more *inclusive proton data*?

[arXiv:2309.12986](https://arxiv.org/abs/2309.12986)

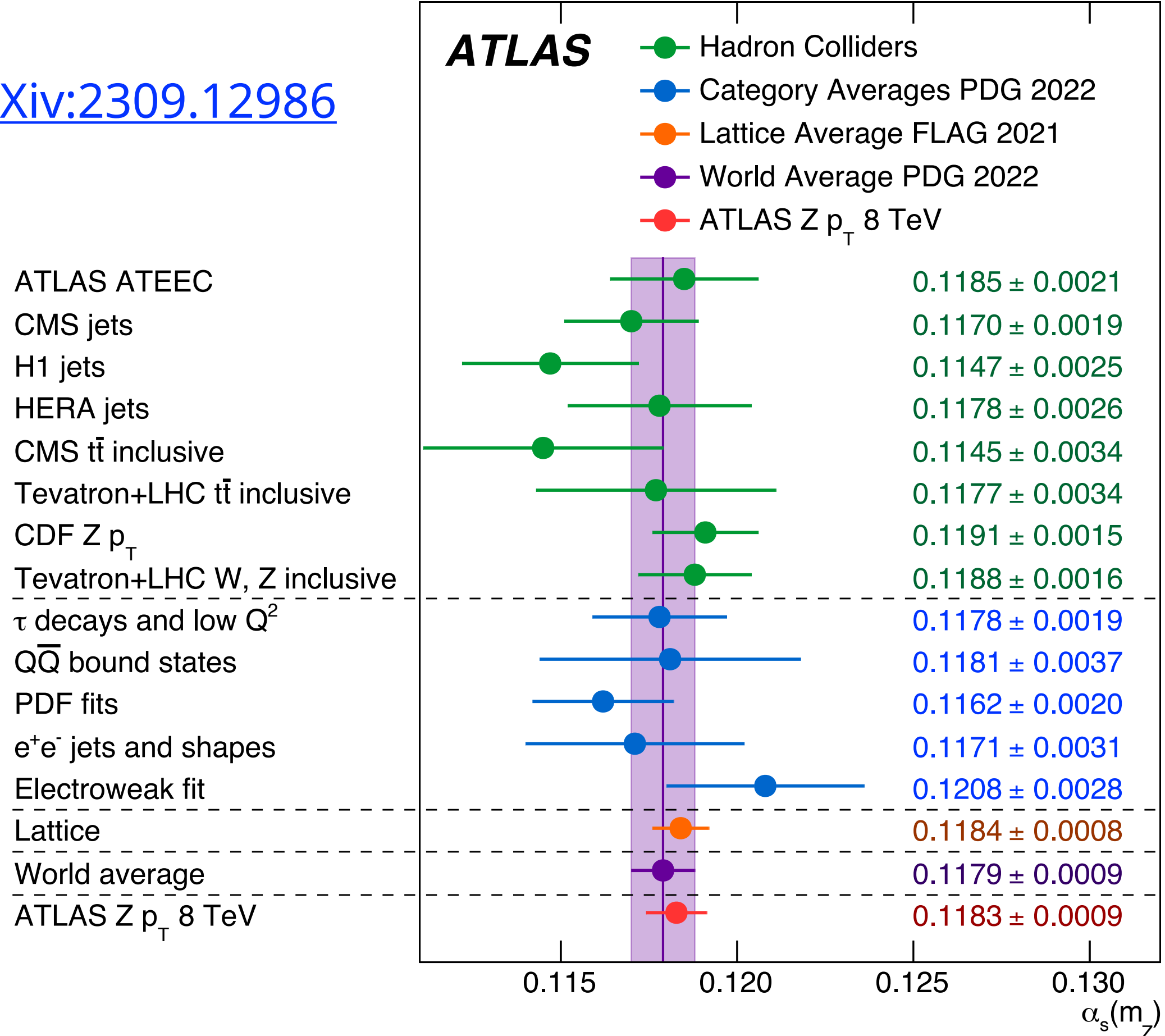

$\delta_{tot} = 0.0009$
 $\delta_{PDF} = 0.0005$

[arXiv.2412.13872](https://arxiv.org/abs/2412.13872)

Electroweak fit
 PRD 110 (2024) 030001
 LEP combination
 Phys. Rep. 532 (2013) 119
 D0
 PRL 108 (2012) 151804
 CDF
 Science 376 (2022) 6589
 LHCb
 JHEP 01 (2022) 036
 ATLAS
 arXiv:2403.15085
 CMS
 This work

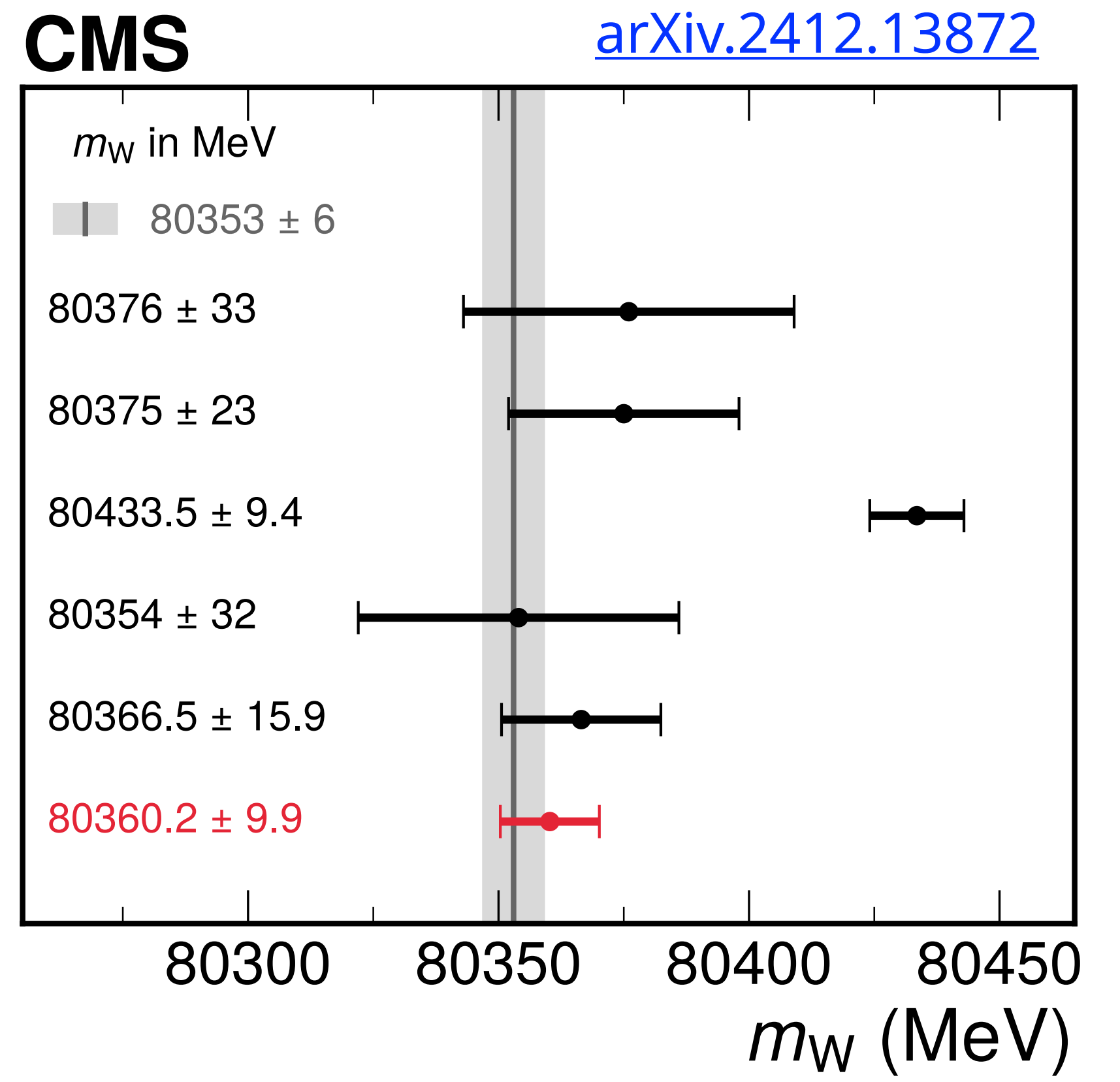

$\delta_{tot} = 9.9 \text{ MeV}$
 $\delta_{PDF} = 4.4 \text{ MeV}$

Inclusive NC cross sections

- <30% resolution in y across x - Q^2 acceptance
- Precision determination of cross sections
 - Systematics-limited at nearly all kinematics

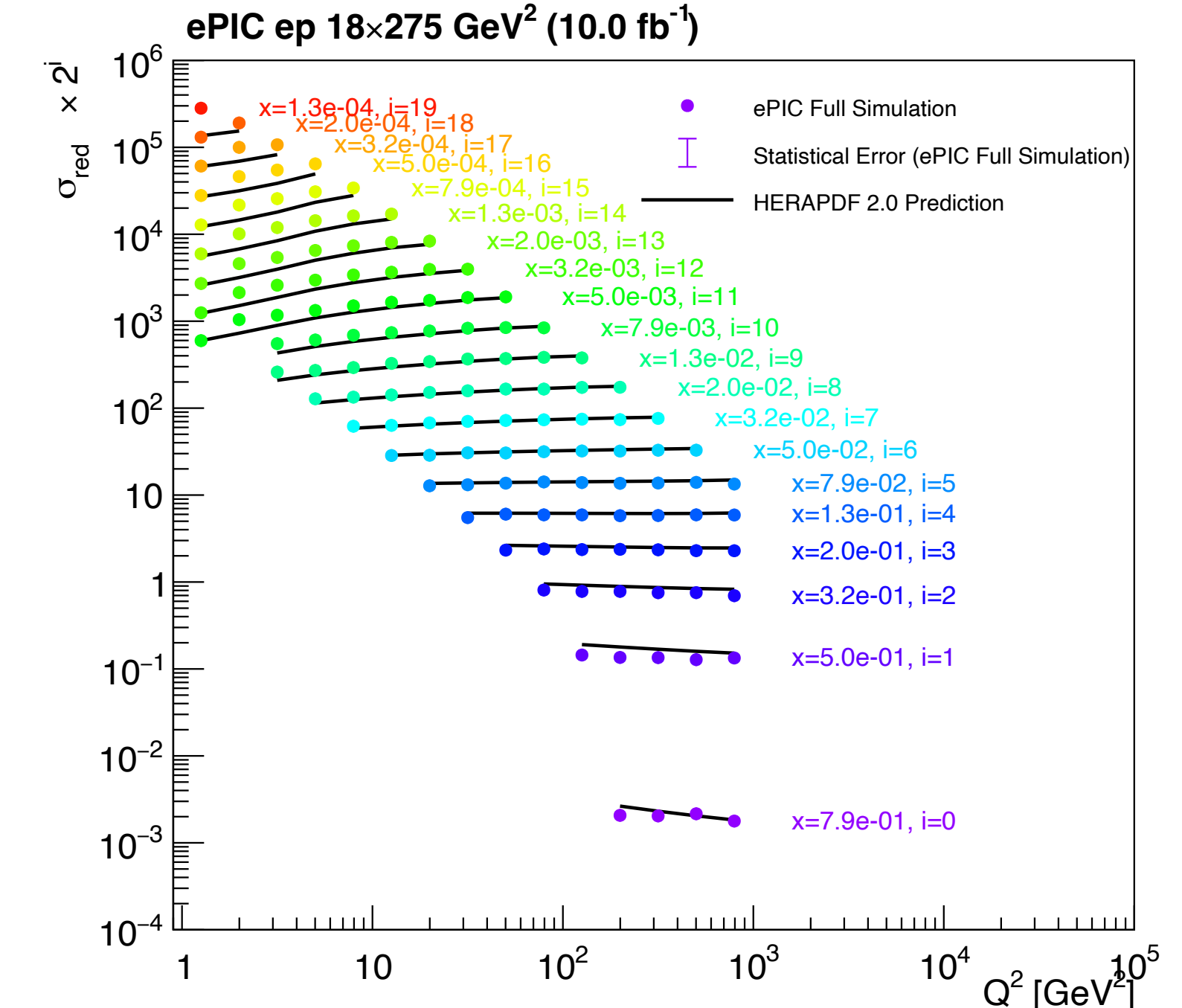
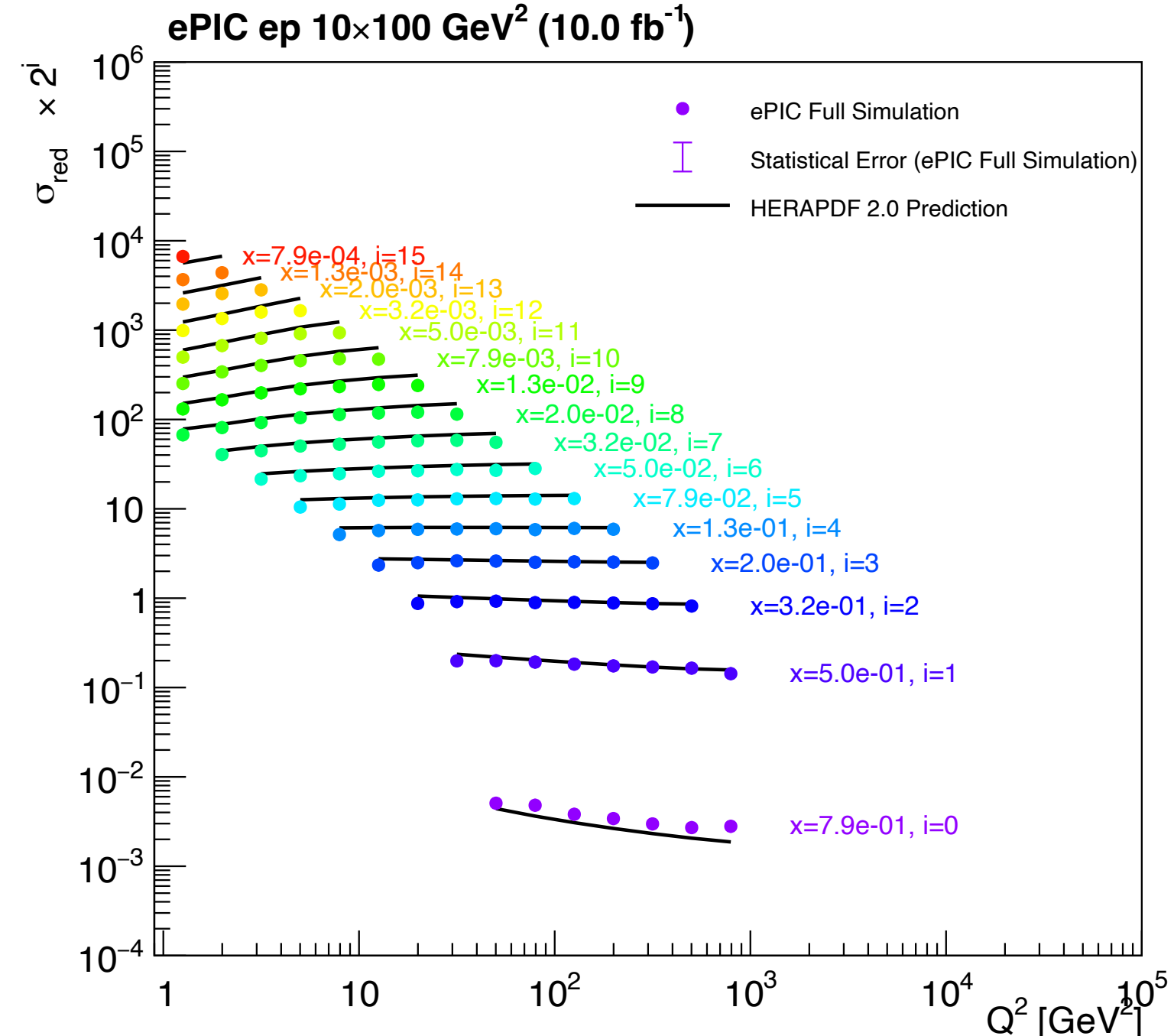
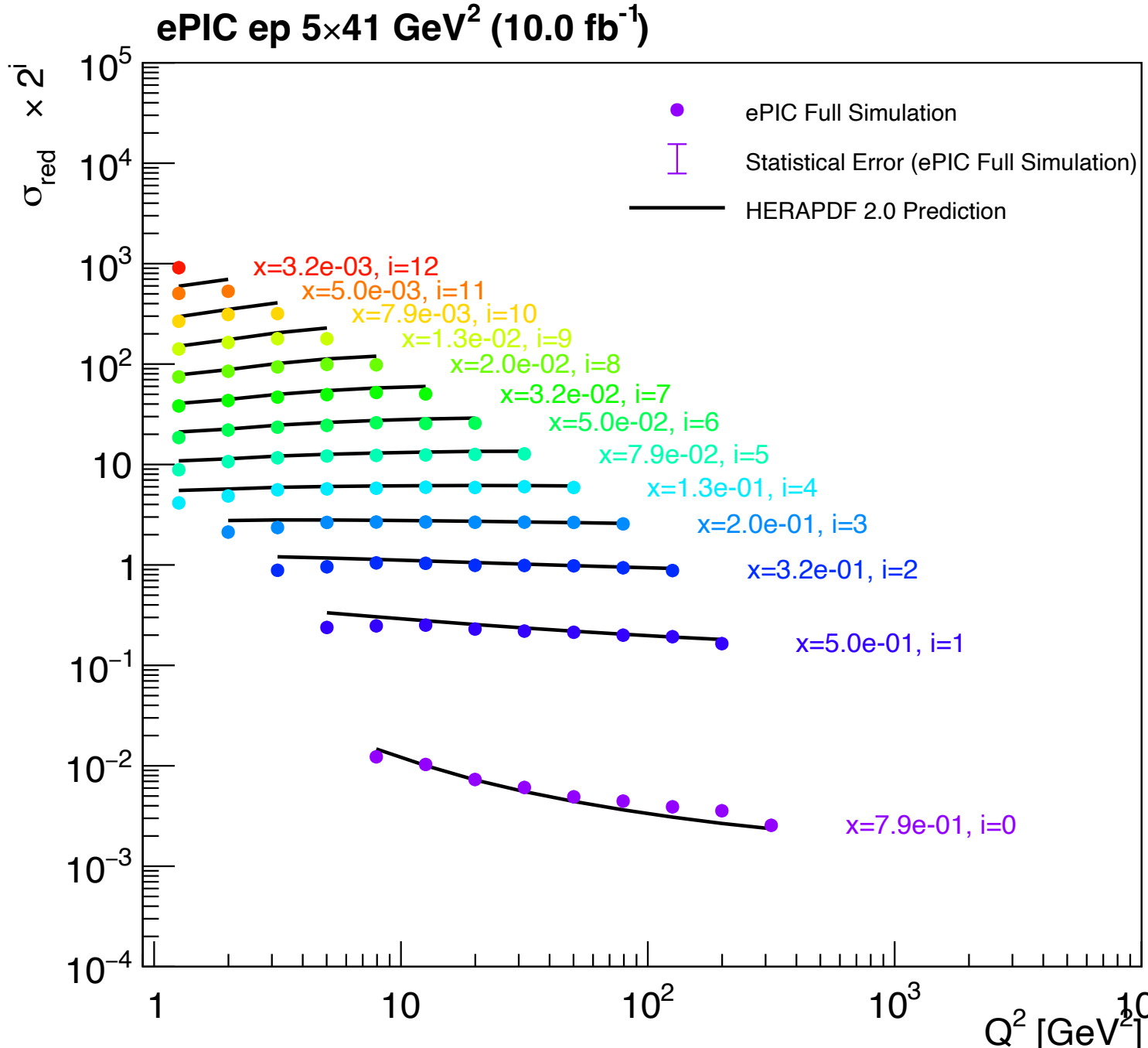
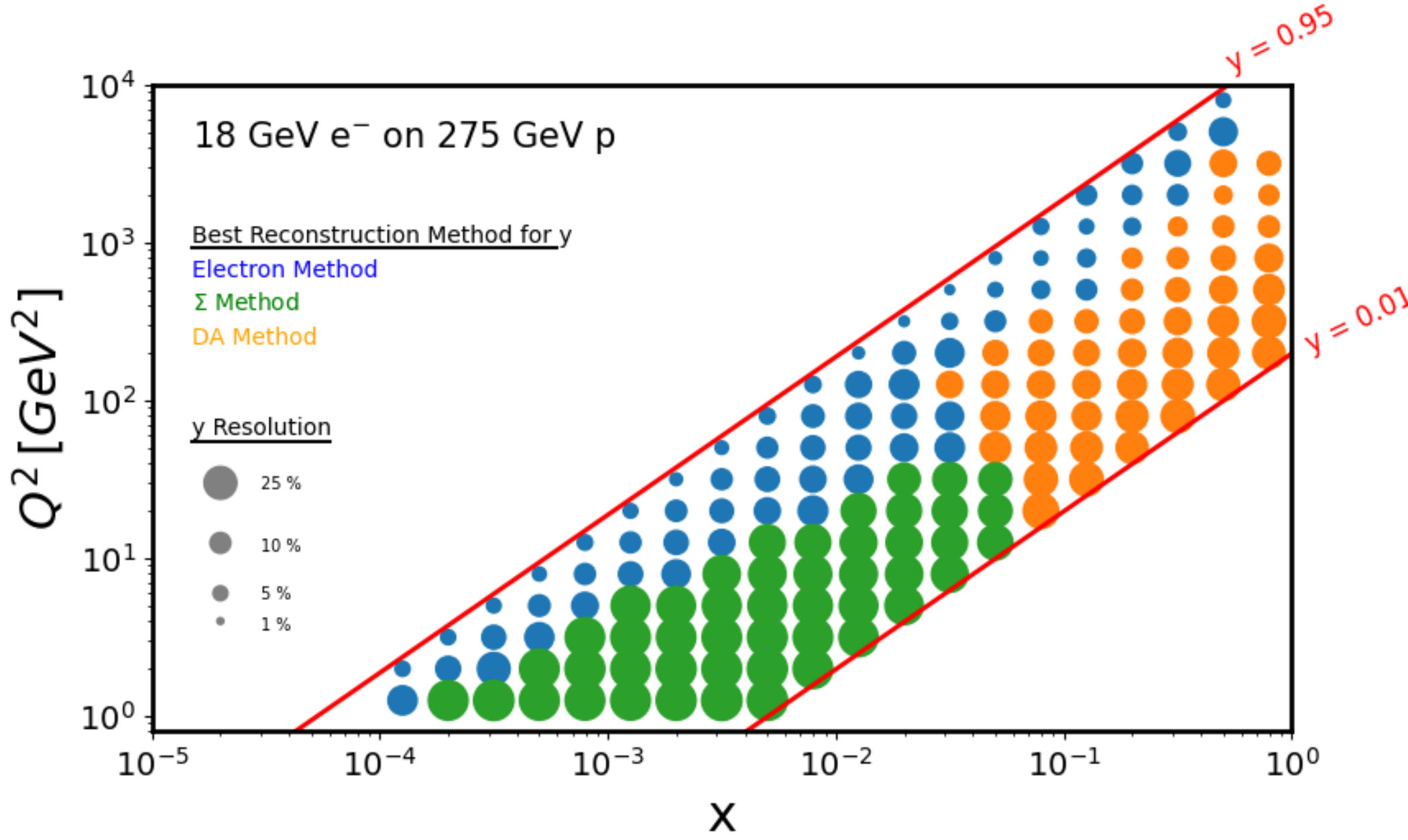

Projected impact on proton PDFs

PRD 109, 054019 (2024)

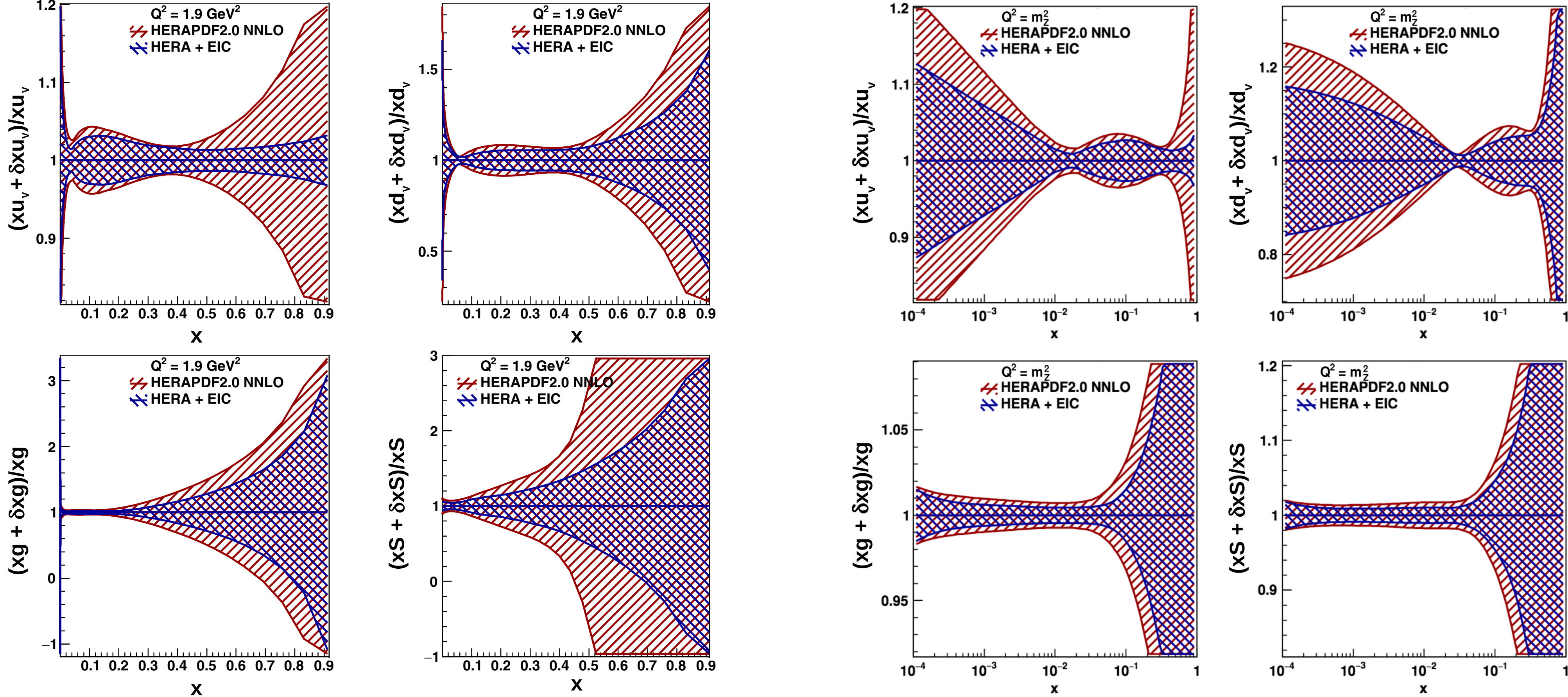

- Assumes 1 year of running (design luminosity) at five center of mass energies
- Conservative systematics based on HERA experience
- Biggest impact at large x

Polarized PDFs describe helicity of quarks & gluons

$$g_1 = \frac{1}{2} \sum_q e_q^2 (\Delta q + \Delta \bar{q})$$

Polarized PDFs describe helicity of quarks & gluons

$$g_1 = \frac{1}{2} \sum_q e_q^2 (\Delta q + \Delta \bar{q})$$

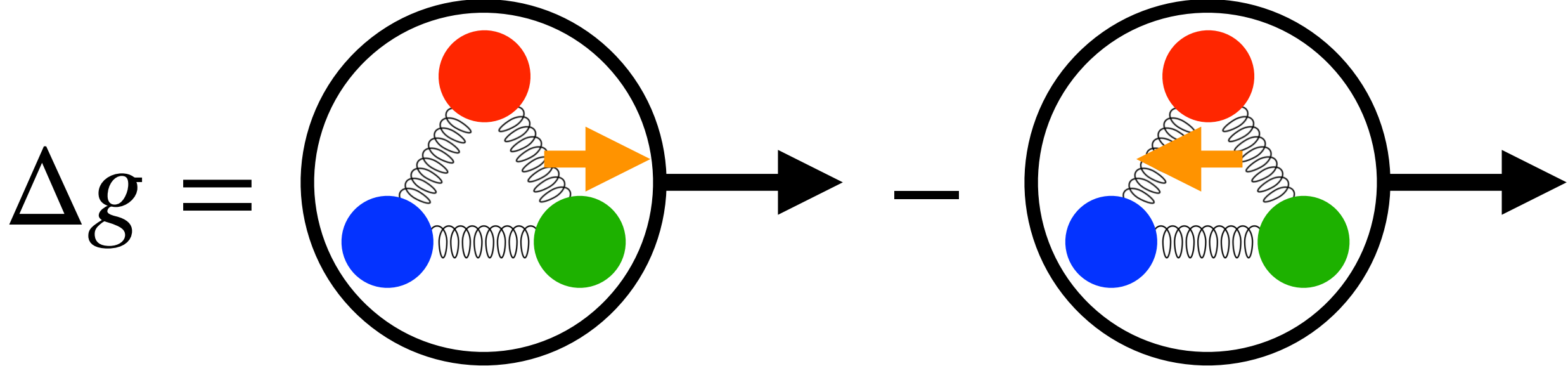
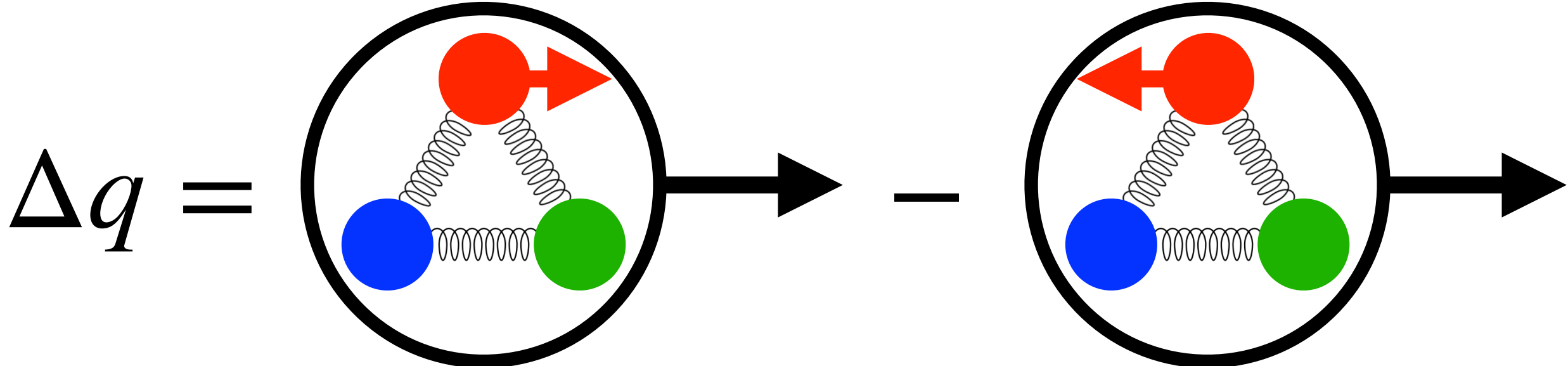

Polarized PDFs describe helicity of quarks & gluons

Extract g_1 from double-spin asymmetry

$$g_1 = \frac{1}{2} \sum_q e_q^2 (\Delta q + \Delta \bar{q})$$

$$g_1 \propto \frac{\sigma^{\leftarrow\rightarrow} - \sigma^{\rightarrow\rightarrow}}{\sigma^{\leftarrow\rightarrow} + \sigma^{\rightarrow\rightarrow}}$$

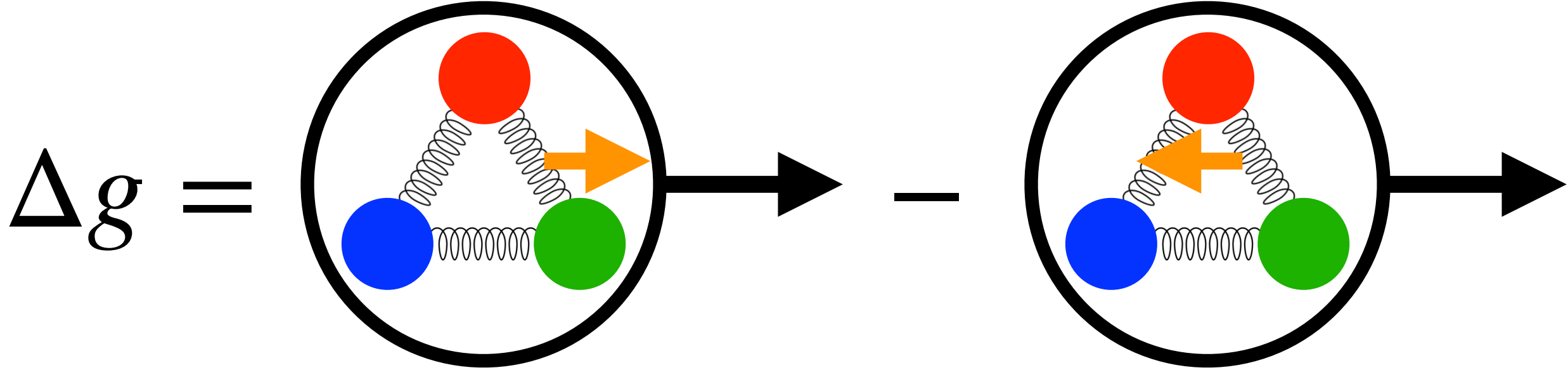
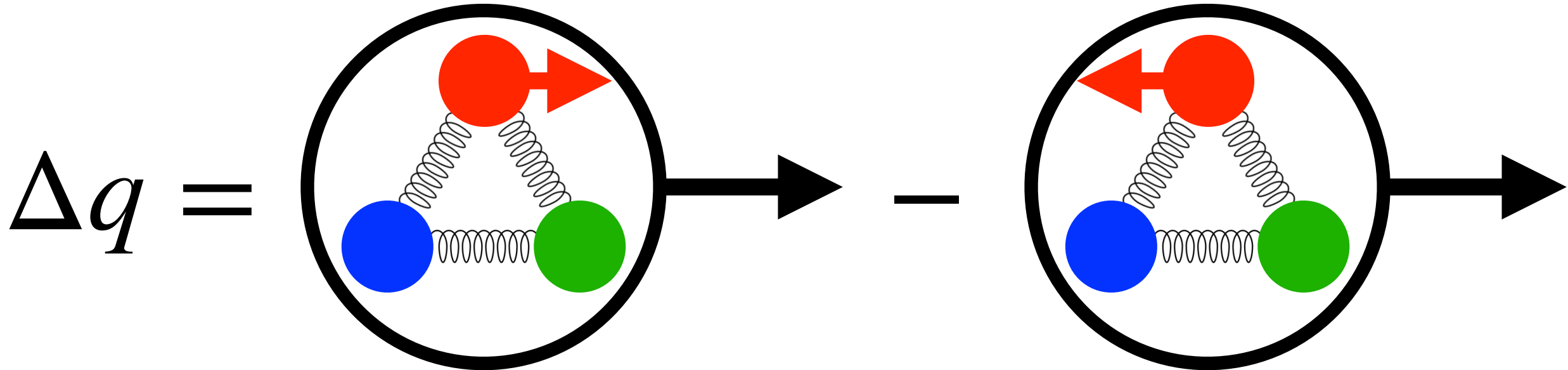

Polarized PDFs describe helicity of quarks & gluons

Extract g_1 from double-spin asymmetry

$$g_1 = \frac{1}{2} \sum_q e_q^2 (\Delta q + \Delta \bar{q})$$

$$g_1 \propto \frac{\sigma^{\leftarrow\rightarrow} - \sigma^{\rightarrow\rightarrow}}{\sigma^{\leftarrow\rightarrow} + \sigma^{\rightarrow\rightarrow}}$$

Contribution to spin of the nucleon:

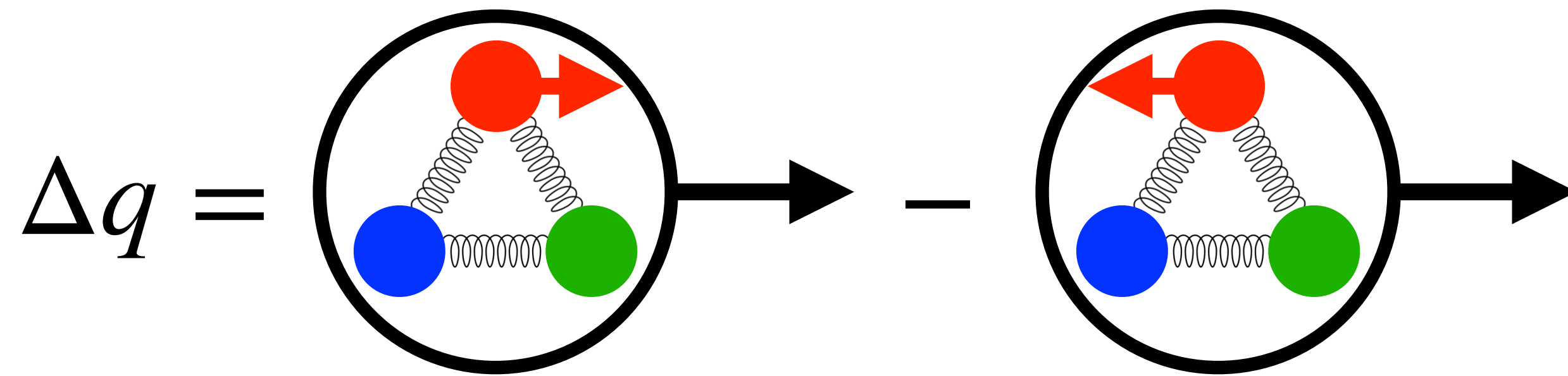

$$\Delta \Sigma \equiv \int (\Delta q + \Delta \bar{q}) dx$$

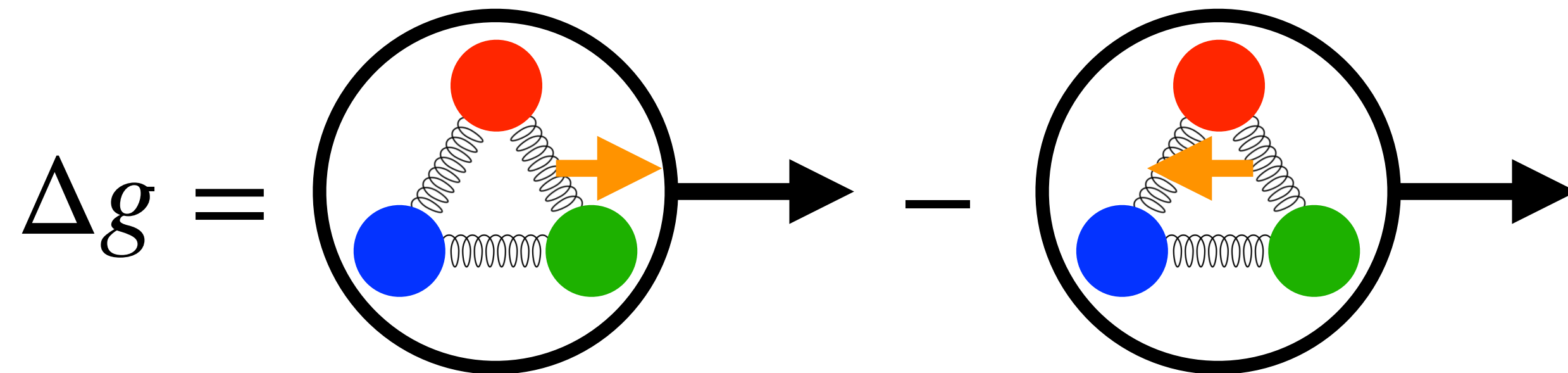

$$\Delta G \equiv \int \Delta g dx$$

Current accounting of proton spin is incomplete

[PLB 753, 18 \(2016\)](#)

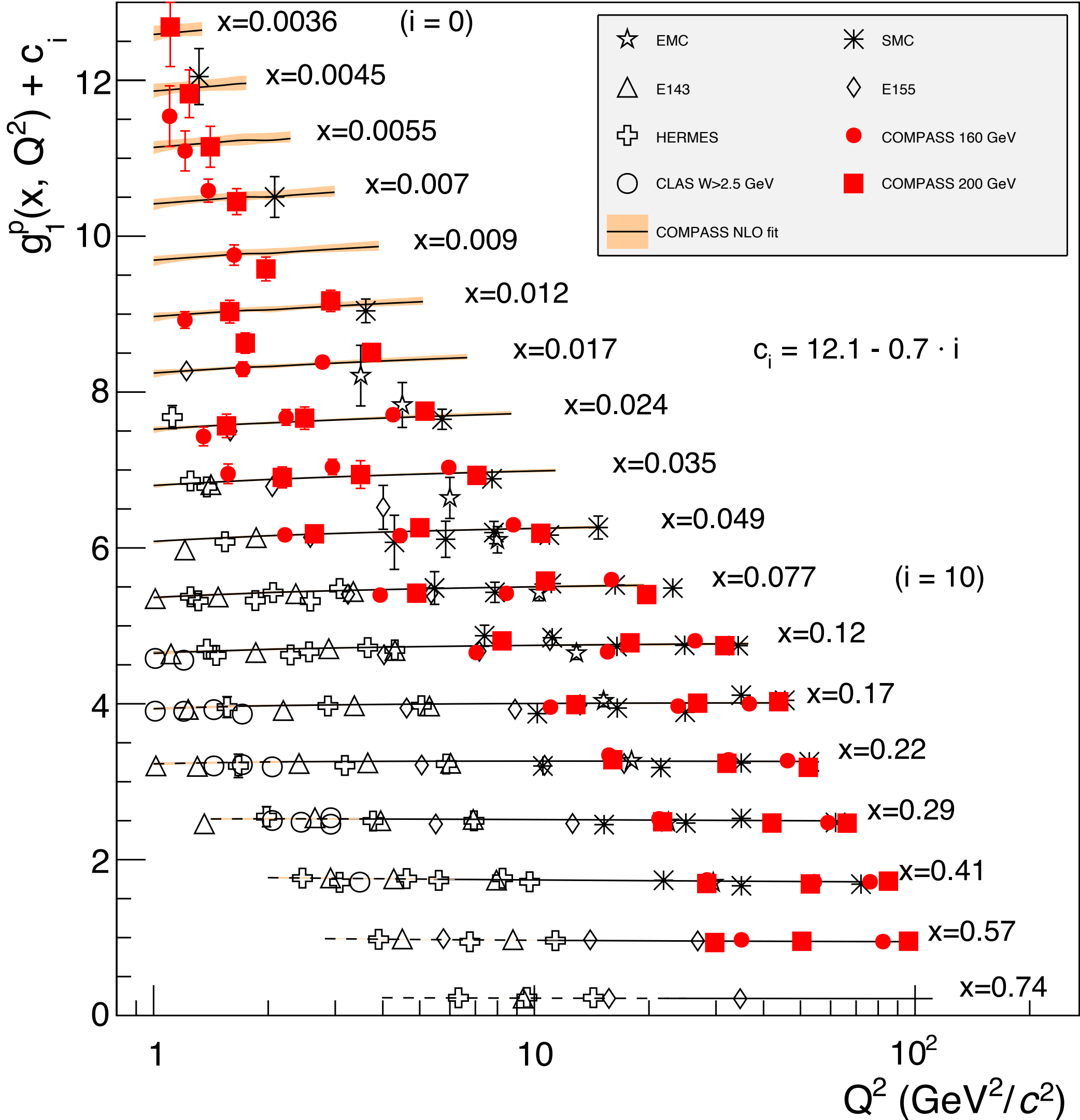

Current accounting of proton spin is incomplete

[PLB 753, 18 \(2016\)](#)

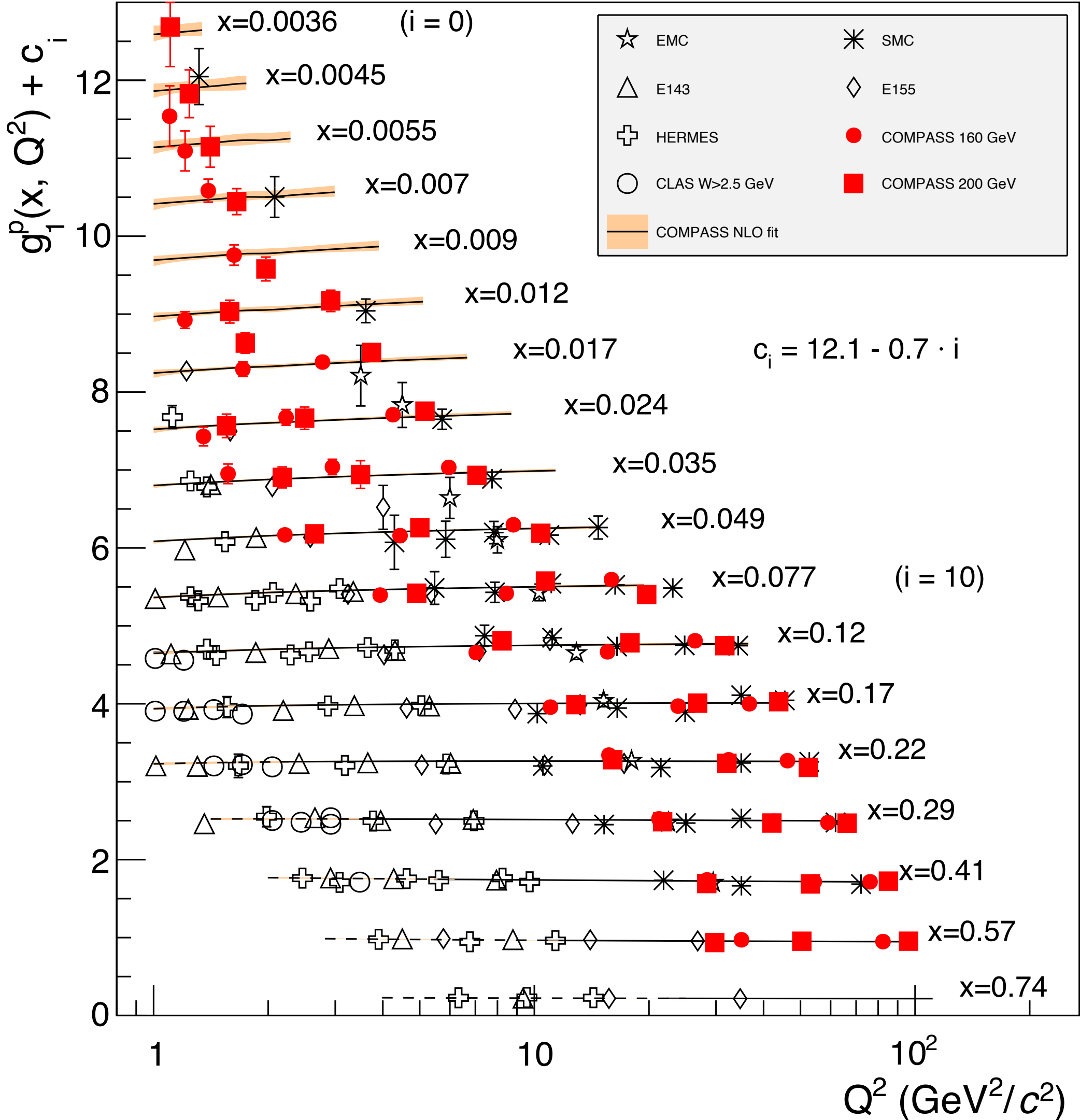

Current accounting of proton spin is incomplete

[PLB 753, 18 \(2016\)](#)

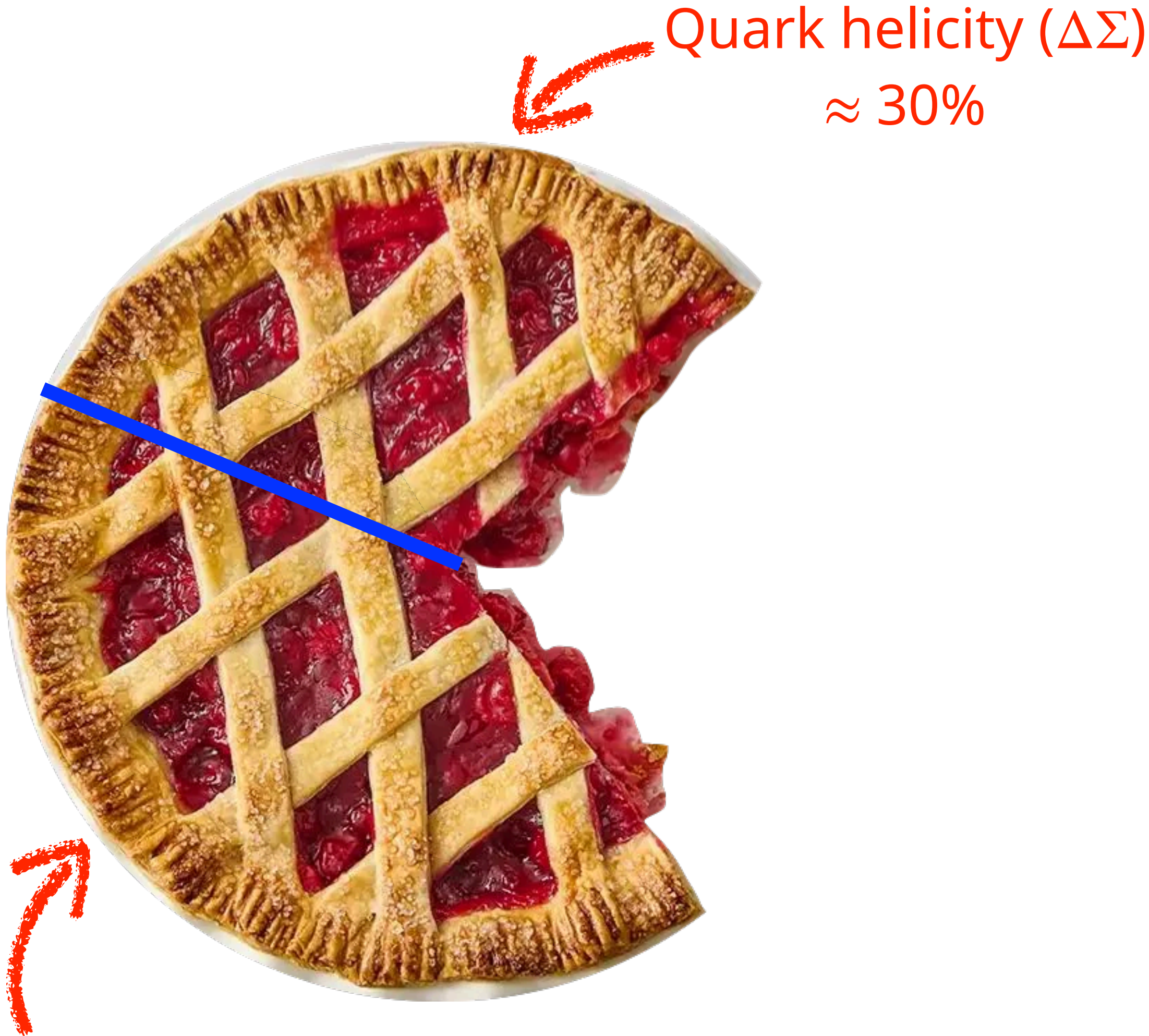
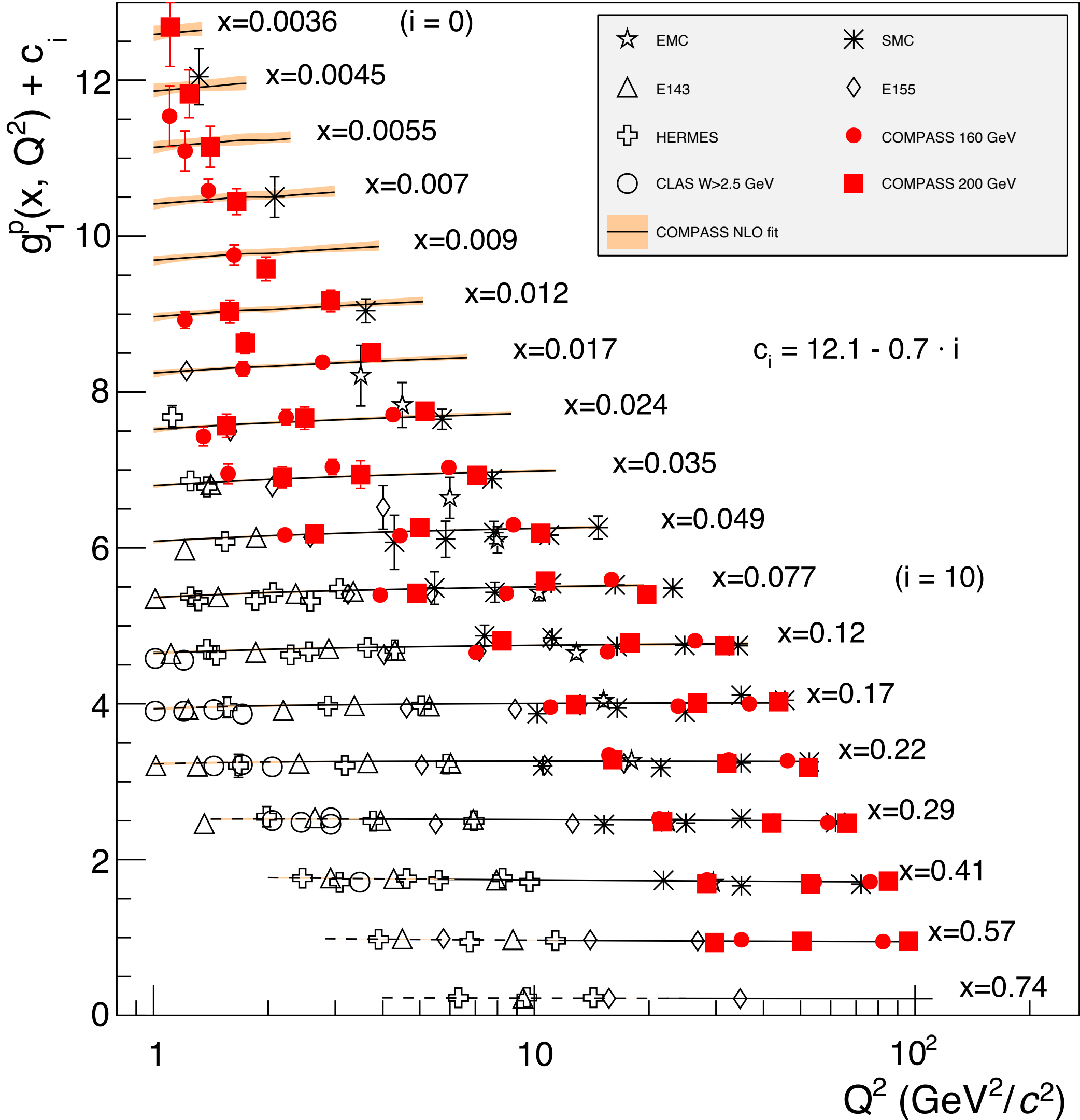

Quark helicity ($\Delta\Sigma$)
 $\approx 30\%$

Gluon helicity (ΔG)
up to 40%?
Large uncertainties!

Current accounting of proton spin is incomplete

PLB 753, 18 (2016)

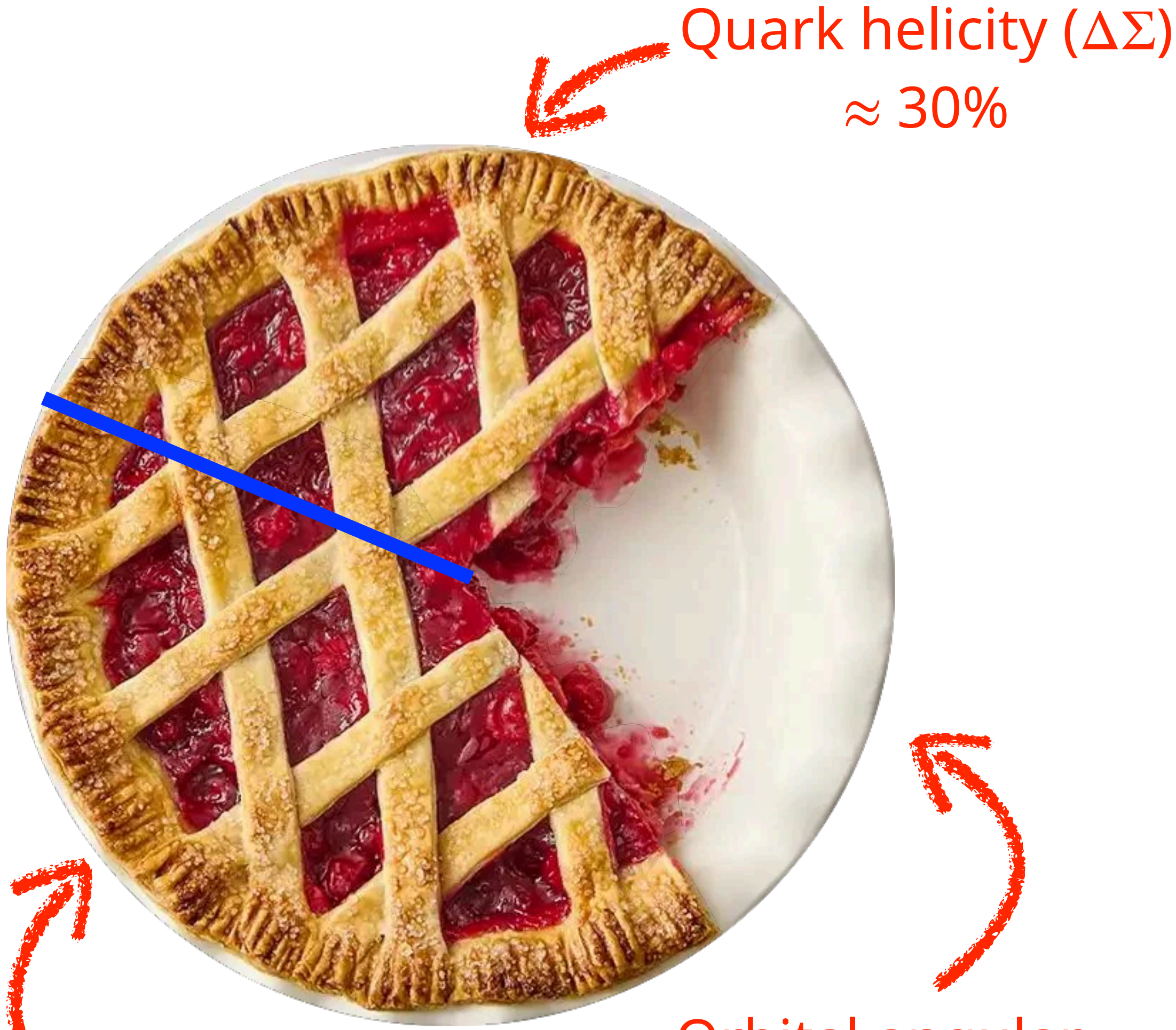
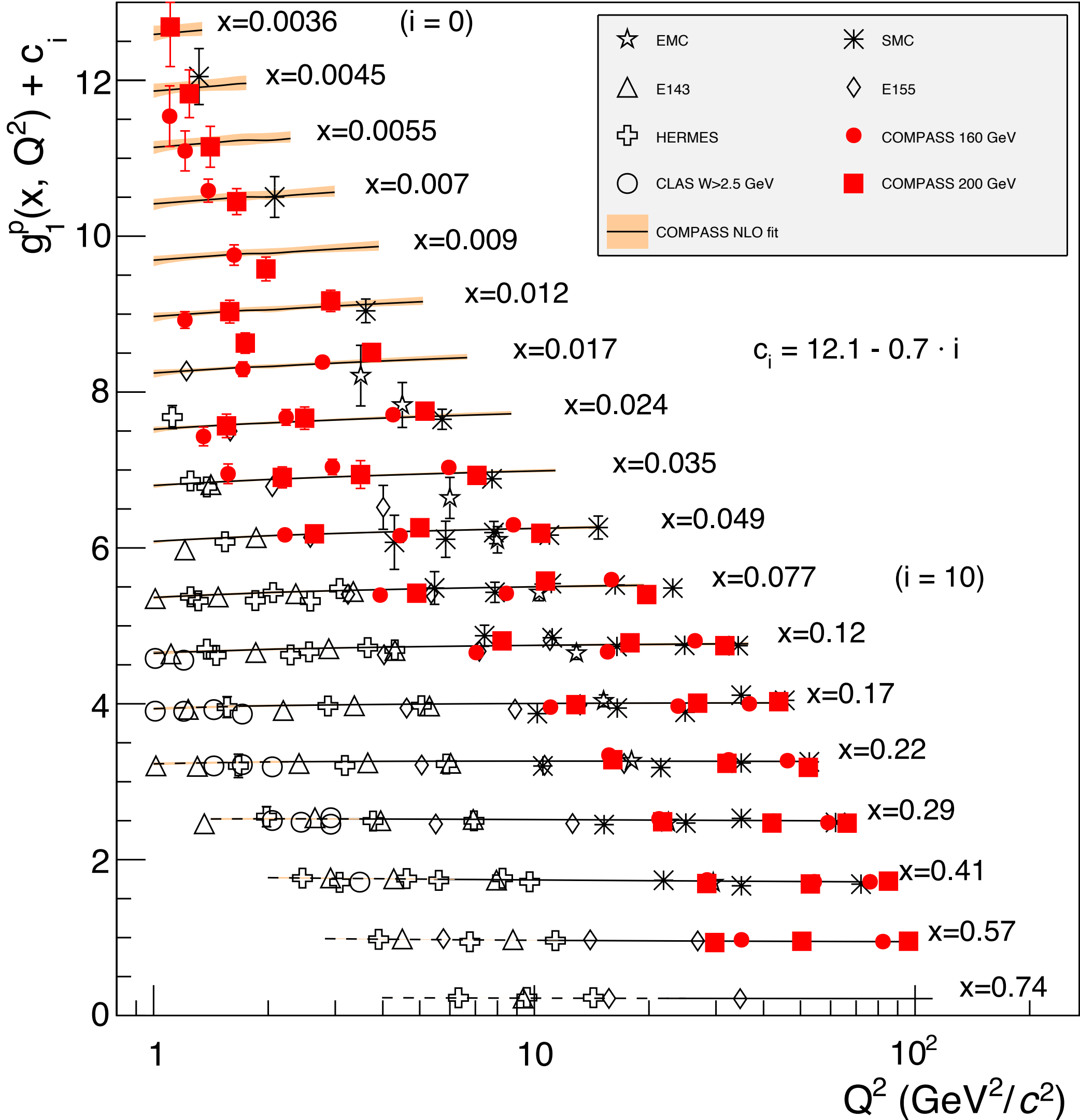

Quark helicity ($\Delta\Sigma$)
 $\approx 30\%$

Gluon helicity (ΔG)
up to 40%?
Large uncertainties!

Orbital angular momentum?
Need 3D structure!

Projected g_1^p coverage at the EIC

- Increased Q^2 coverage at all x
- Extend x coverage down to 10^{-4}
- Requires pure electron sample
→ “stress test” of electron ID!

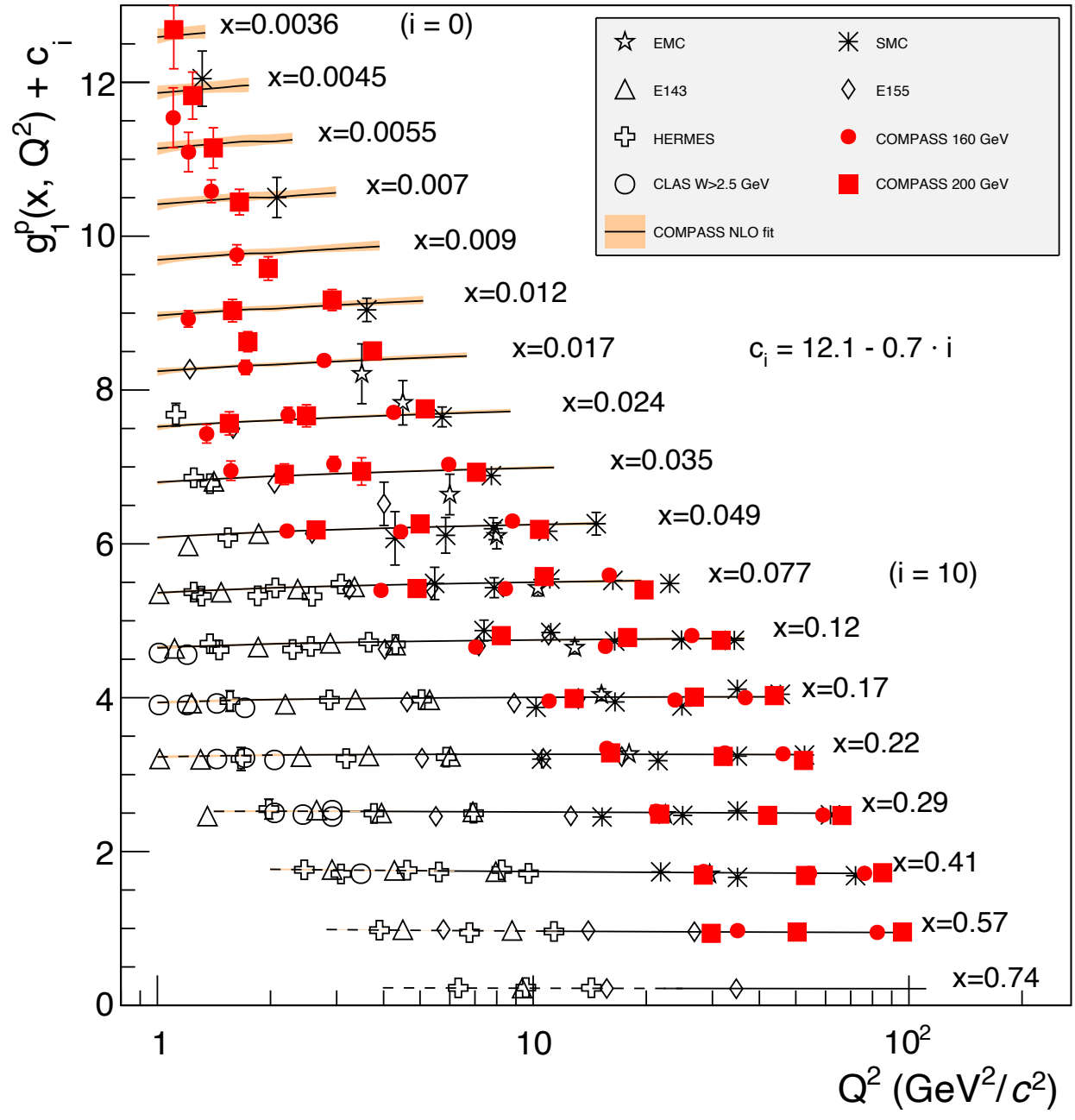

Existing data

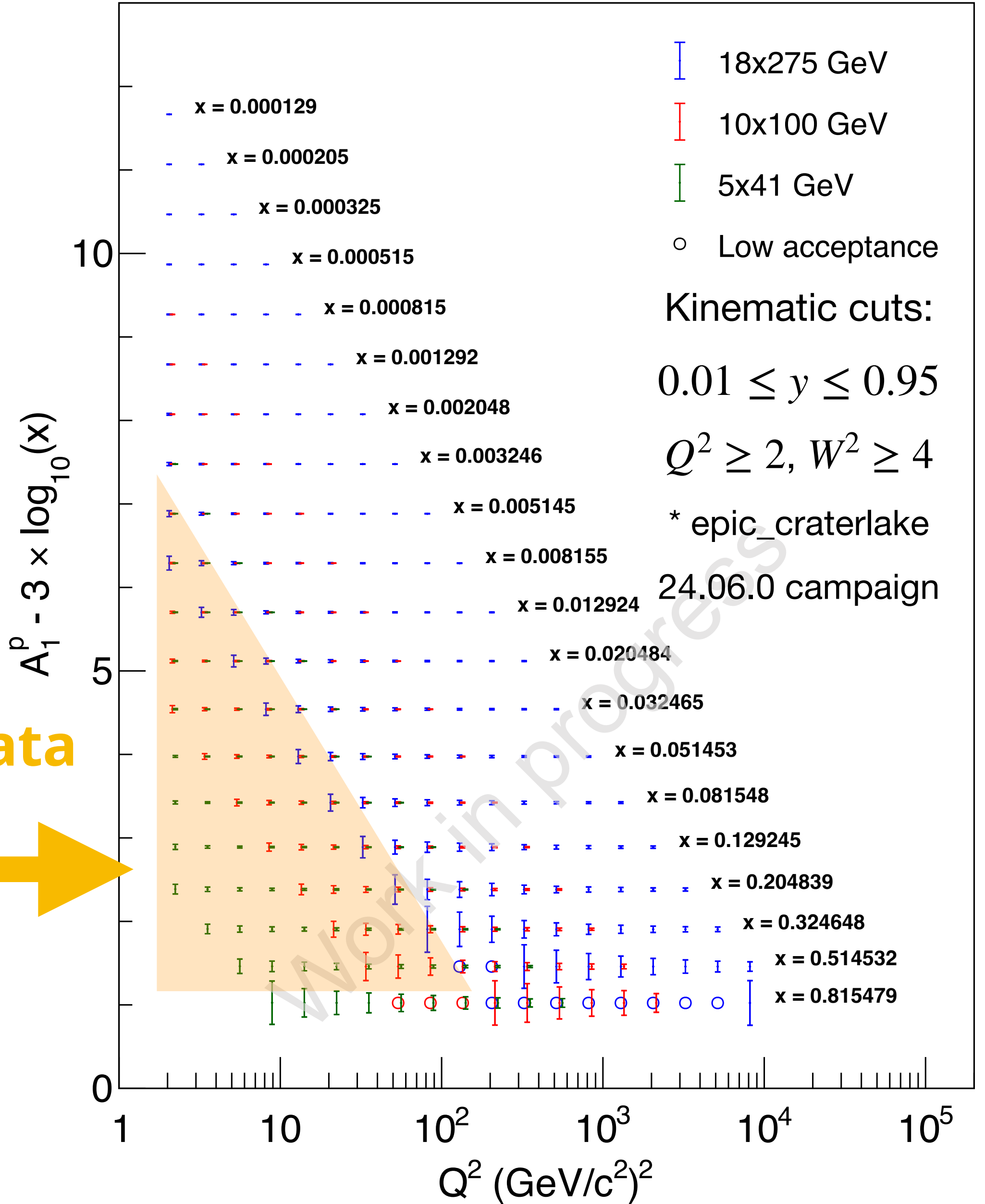

Impact of EIC measurements on quarkgluon helicity

[NPA, 1026, 122447 \(2022\)](#)

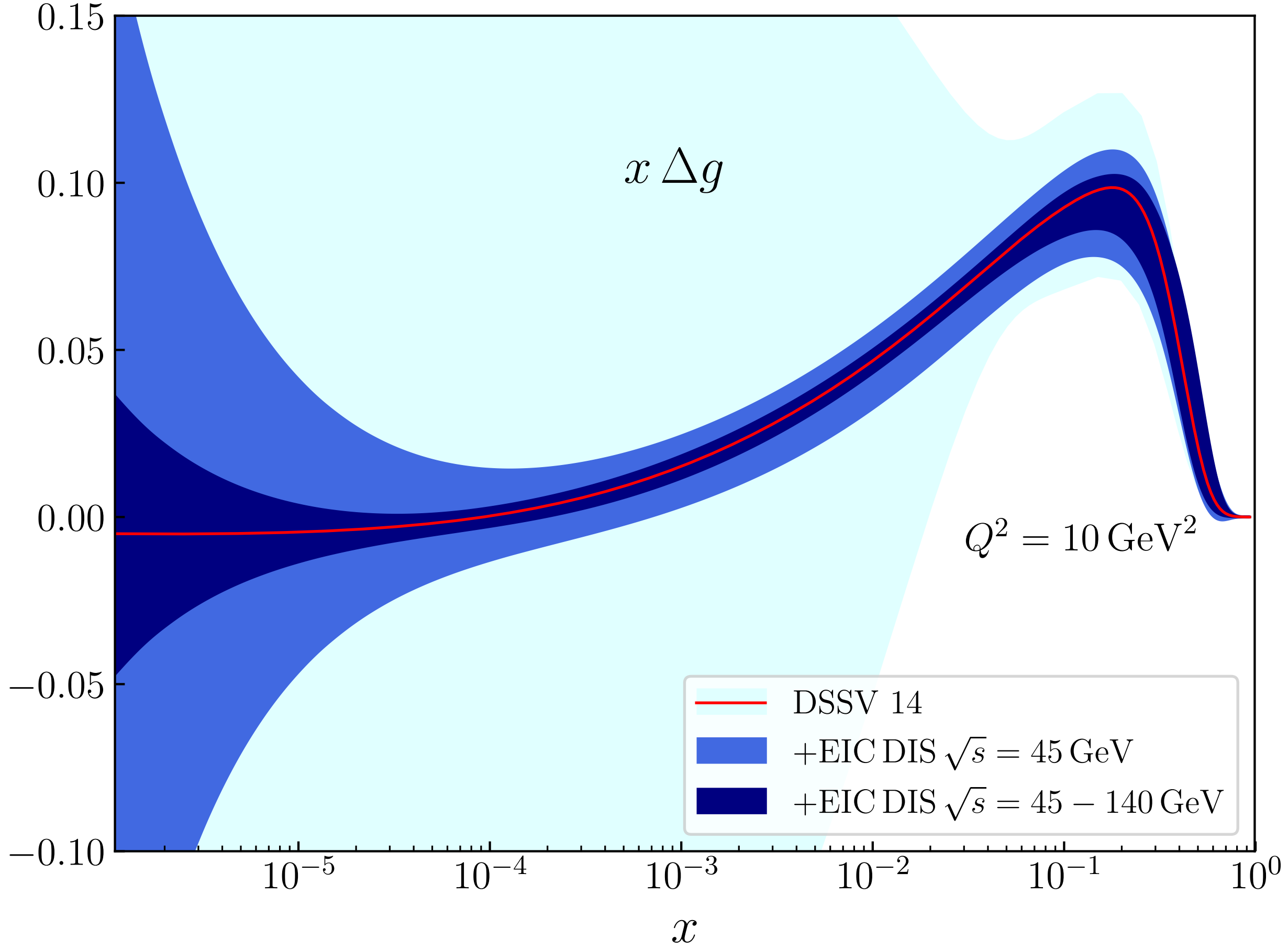
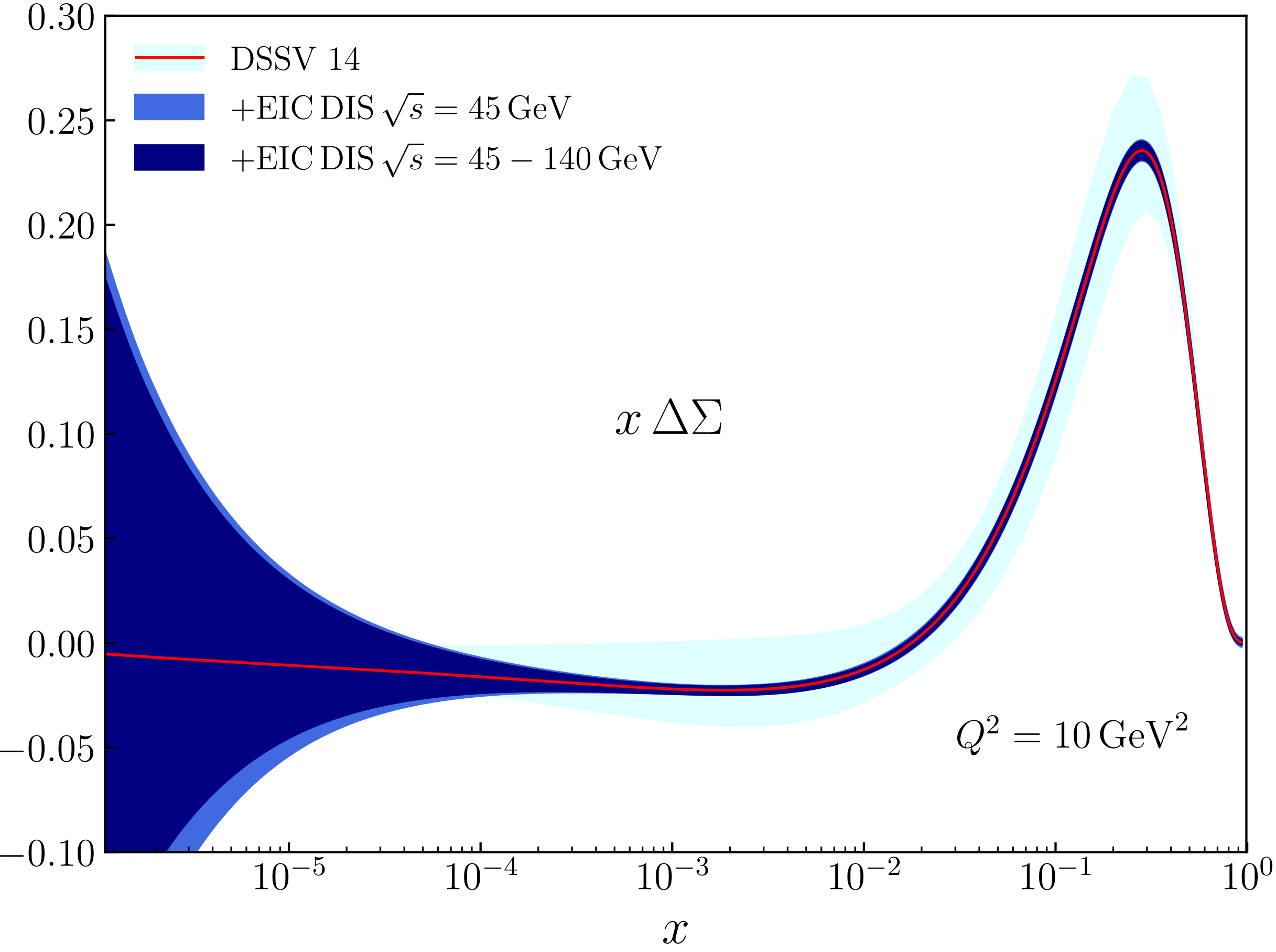

Beyond longitudinal PDFs: The proton's 3D structure

Transverse momentum distributions (TMDs)

- Accessed through SIDIS processes
- Orbital motion, spin-orbit effects
- Sensitivity to transverse polarization through azimuthal (Collins and Sivers) asymmetries

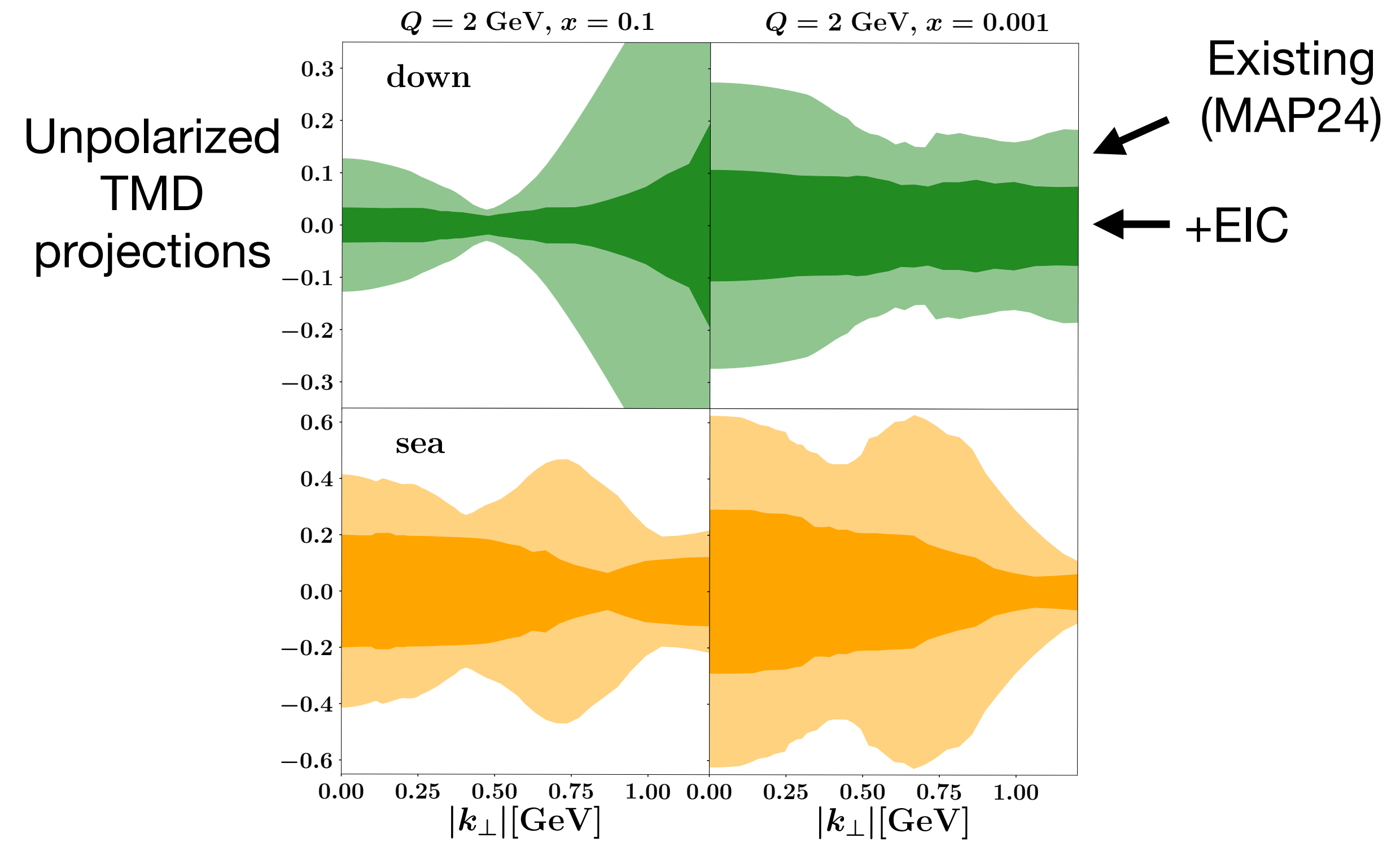

Beyond longitudinal PDFs: The proton's 3D structure

Transverse momentum distributions (TMDs)

- Accessed through SIDIS processes
- Orbital motion, spin-orbit effects
- Sensitivity to transverse polarization through azimuthal (Collins and Sivers) asymmetries

Generalized parton distributions (GPDs)

- Accessed through exclusive processes (DVCS & DVMP)
- Longitudinal momentum and transverse position

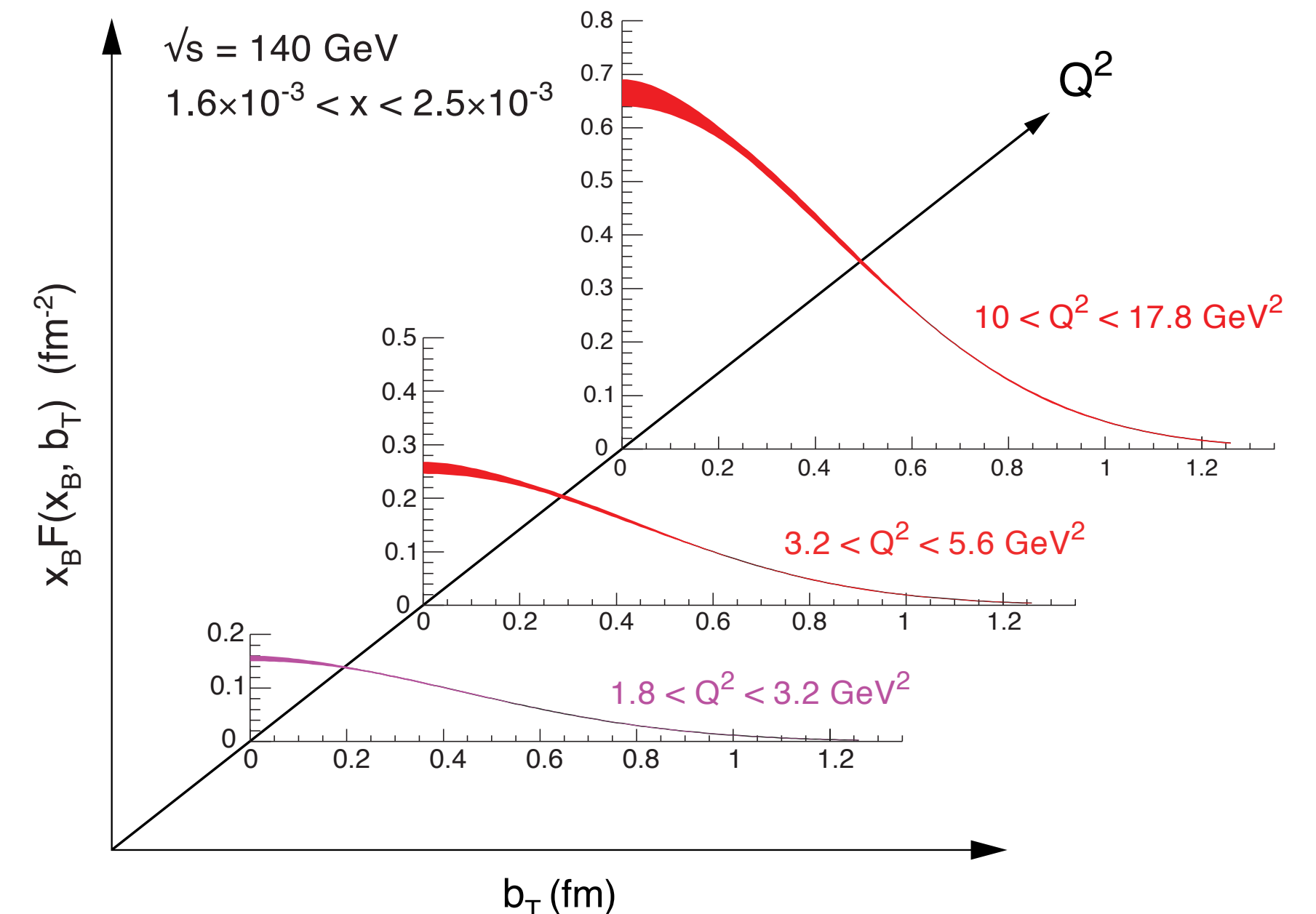
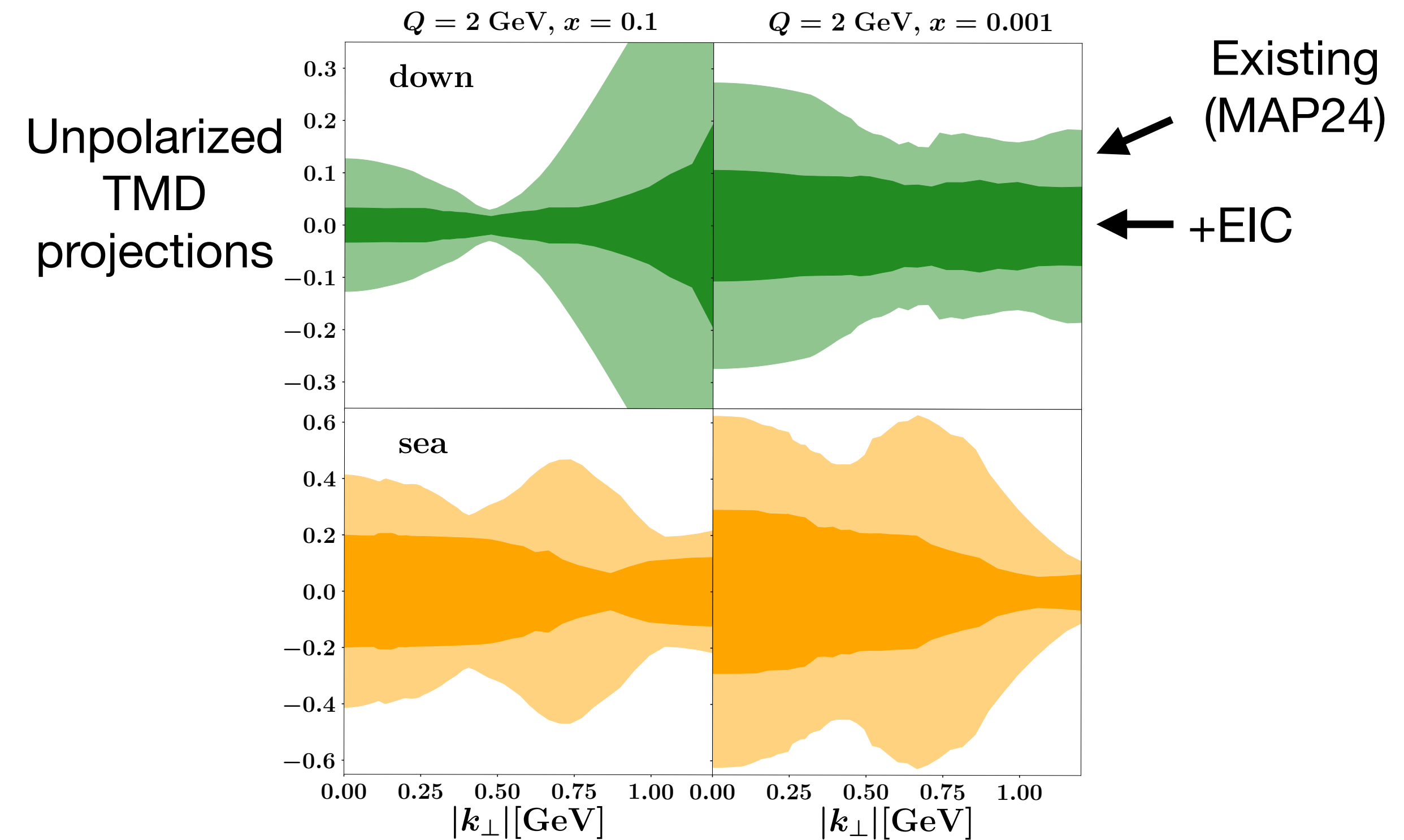

Beyond longitudinal PDFs: The proton's 3D structure

Transverse momentum distributions (TMDs)

- Accessed through SIDIS processes
- Orbital motion, spin-orbit effects
- Sensitivity to transverse polarization through azimuthal (Collins and Sivers) asymmetries

Generalized parton distributions (GPDs)

- Accessed through exclusive processes (DVCS & DVMP)
- Longitudinal momentum and transverse position
- EIC will significantly extend kinematic reach and provide unprecedented precision for sea quark, gluon TMDs and GPDs
- 3D structure critical to understanding parton orbital angular momentum

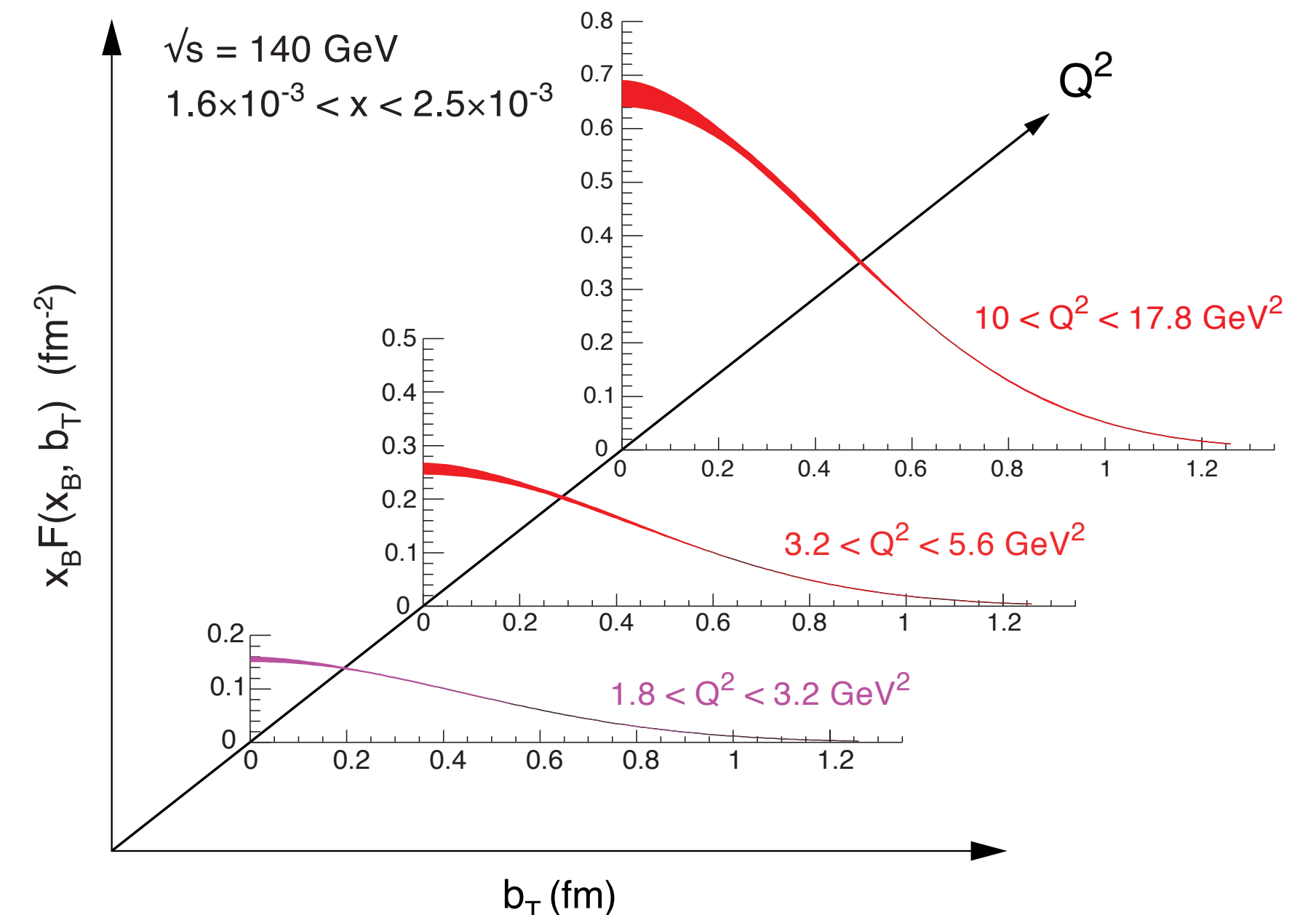
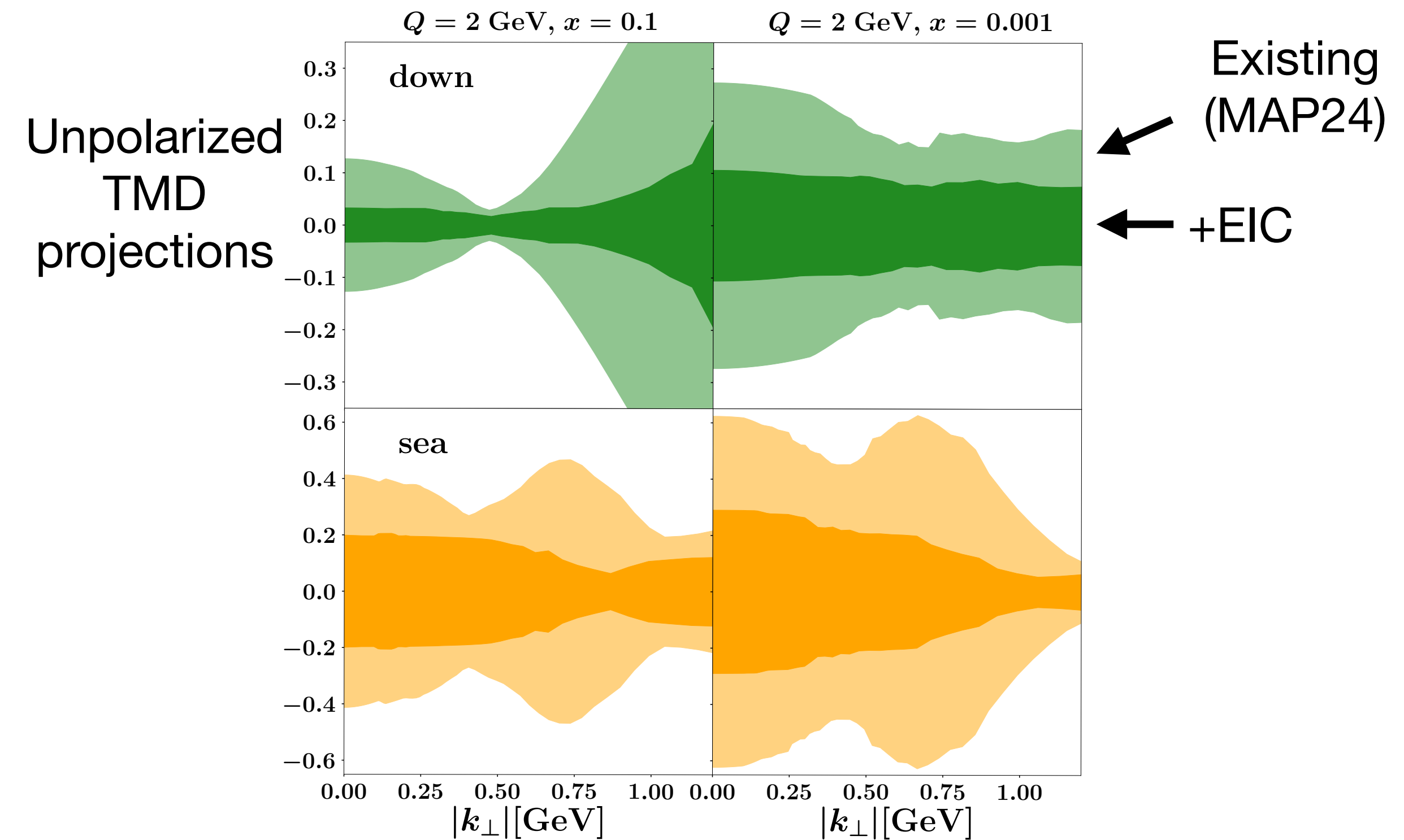

DIS from nuclei

- Existing nuclear DIS data entirely from fixed-target facilities
- EIC will probe nuclear PDFs in new regions of high Q^2 and low x
- Study EMC effect, nuclear medium modification
- Constrain neutron structure with light nuclei

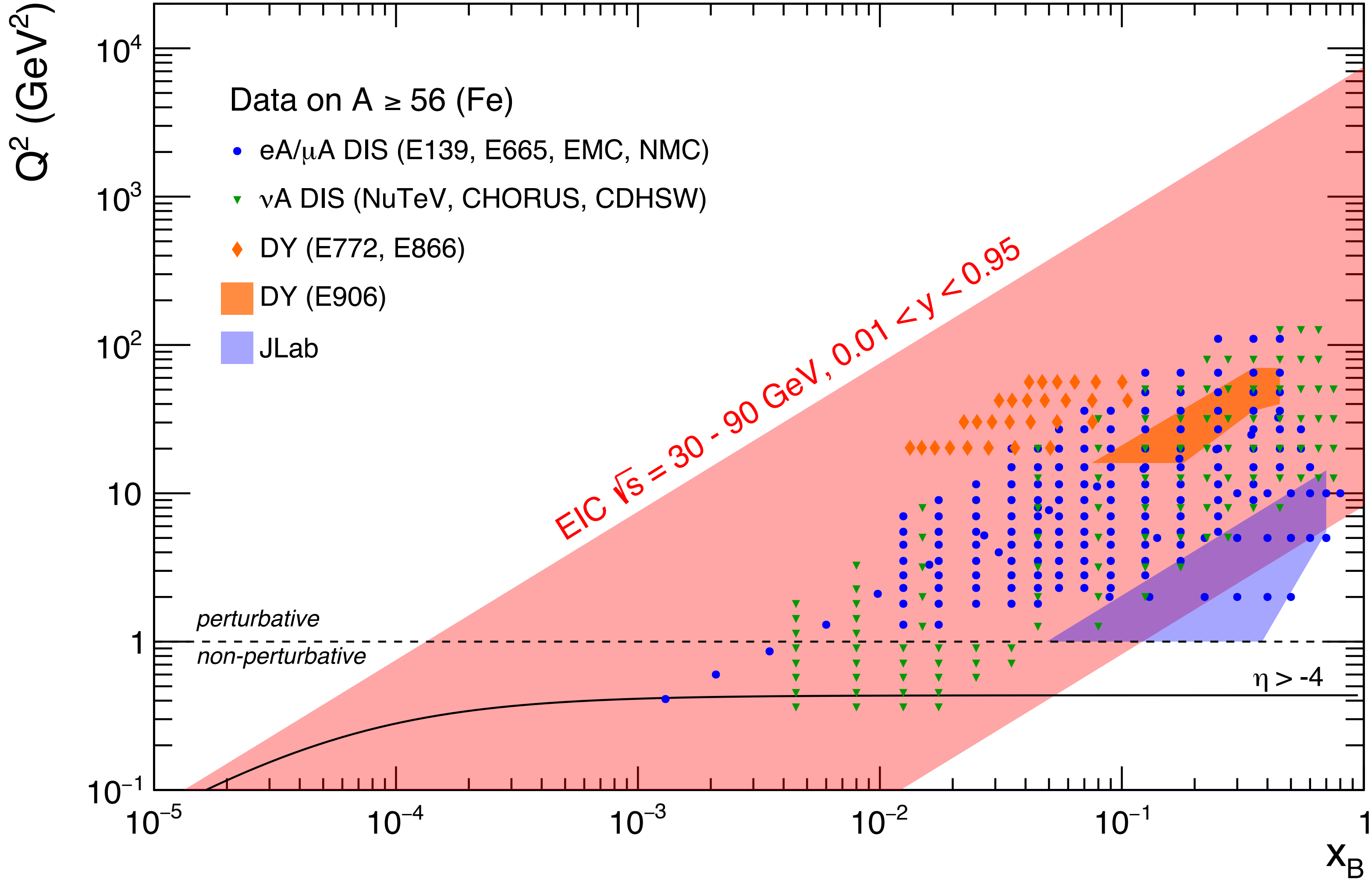

Projected impact on nPDFs

PRD 103, 096005 (2021)

- Assumes 10 fb^{-1} at three center of mass energies for each ion species
- Optimistic vs. pessimistic systematics
- Biggest impact at low, high x
- Larger improvement for heavier nuclei due to A -dependence of nPDFs
→ EIC data will largely equalize uncertainties among nuclei

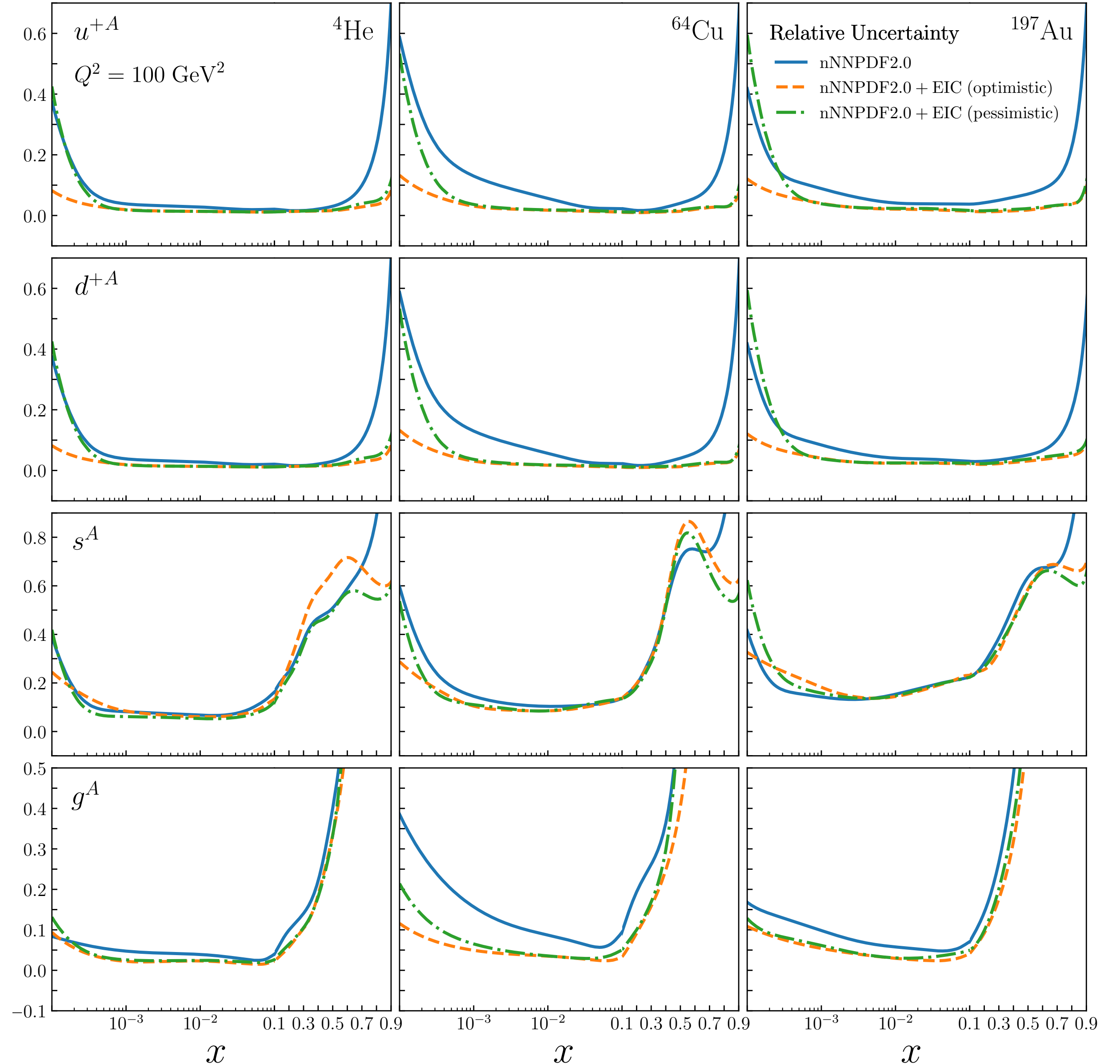

Summary & outlook

- The EIC is a unique facility for understanding QCD
 - Project approved and processing towards realization
 - Likely the only novel high-energy collider for the next 20 years
- The ePIC detector is being developed with the EIC project to deliver the full EIC science program
- Exciting times ahead as the construction and operation of EIC & ePIC quickly approaches
 - Please join us!



Summary & outlook

- The EIC is a unique facility for understanding QCD
 - Project approved and processing towards realization
 - Likely the only novel high-energy collider for the next 20 years
- The ePIC detector is being developed with the EIC project to deliver the full EIC science program
- Exciting times ahead as the construction and operation of EIC & ePIC quickly approaches
 - Please join us!

