

# The ePIC Detector

An Unique General-Purpose Detector for the EIC



*Thomas Ullrich*

Precision QCD Predictions for ep  
Physics at the EIC (3rd Edition)

CFNS, SBU

September 23, 2024

# EIC Physics (= QCD Physics)

Investigate with precision the universal dynamics of gluons to understand the emergence of hadronic and nuclear matter and their properties

## Central Questions:

- How are sea quarks and gluons, and their spins, distributed in space and momentum inside the nucleon? How do the nucleon properties emerge from them and their interactions?
- How do color-charged quarks and gluons, and colorless jets, interact with a nuclear medium? How do confined hadronic states emerge from these quarks and gluons?
- What happens to the exploding gluon density at low- $x$  in hadronic matter? Does it saturate at high energy, giving rise to a gluonic matter with universal properties?

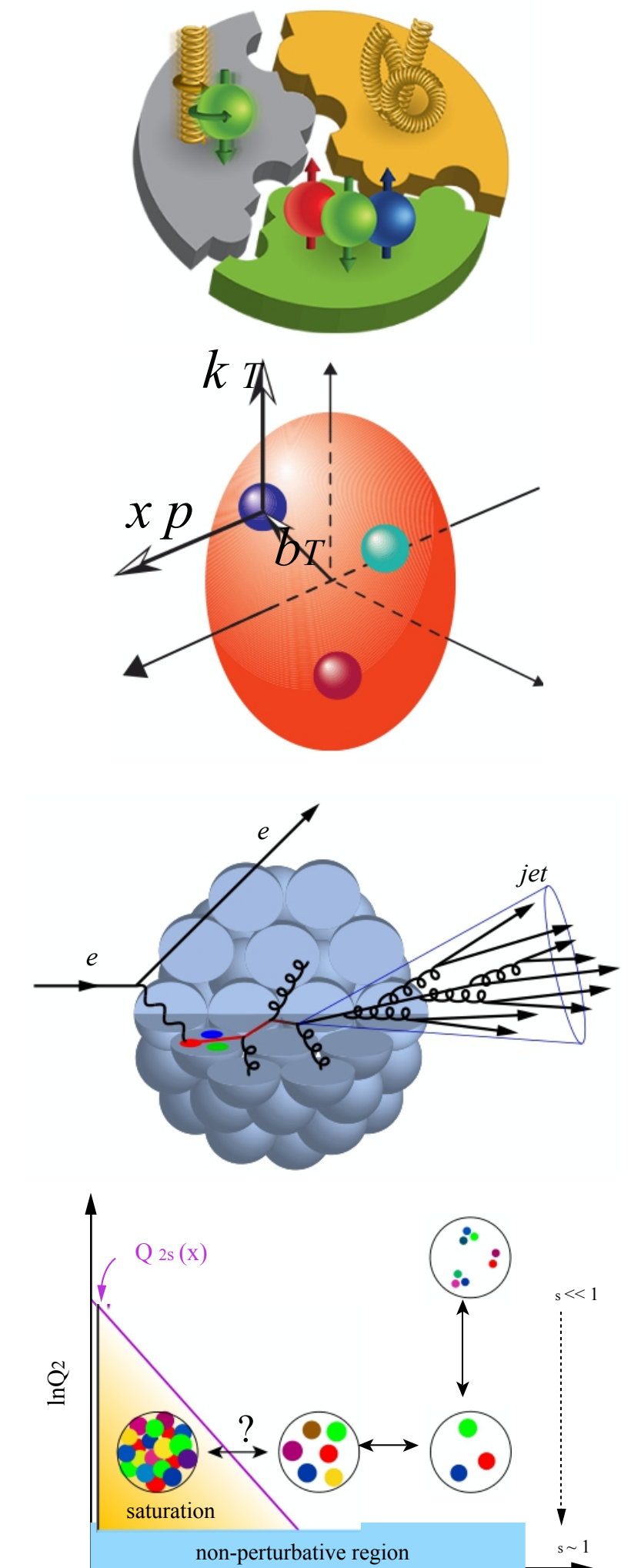

# What Can Provide Answers?

## Hadron-Hadron

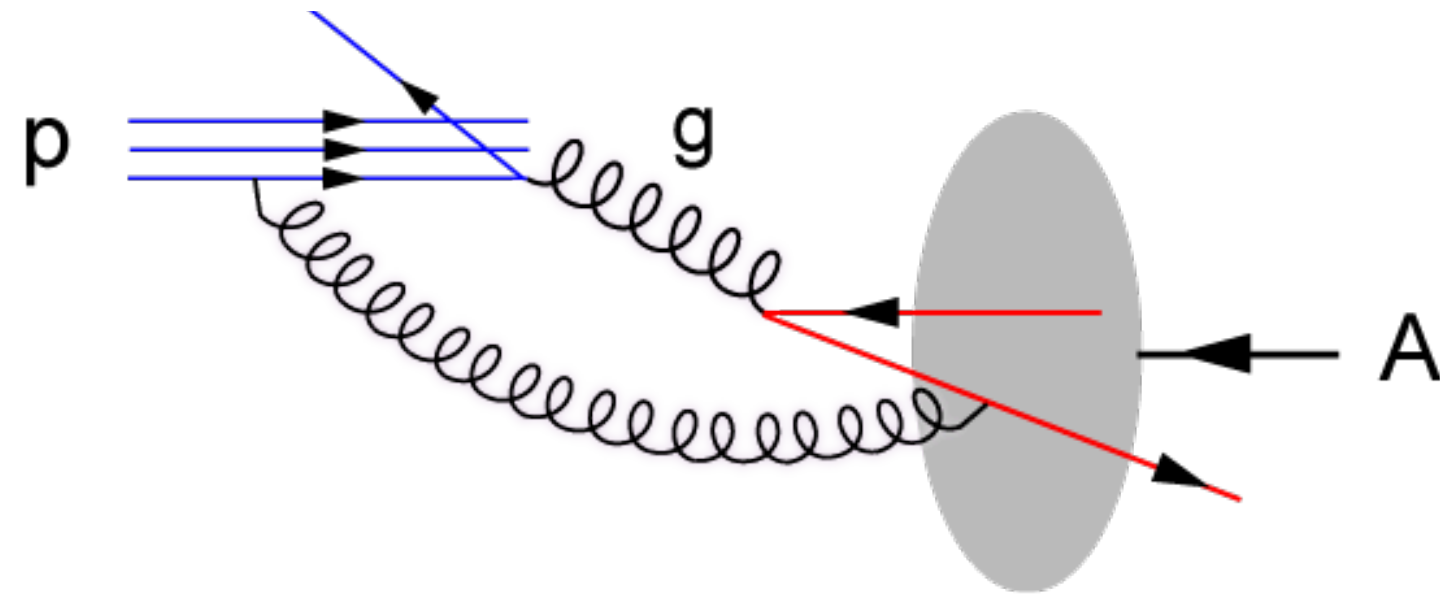

- Test QCD
- Probe/Target interaction directly via gluons
- lacks the direct access to  $x$ ,  $Q^2$

## Electron-Hadron (DIS)

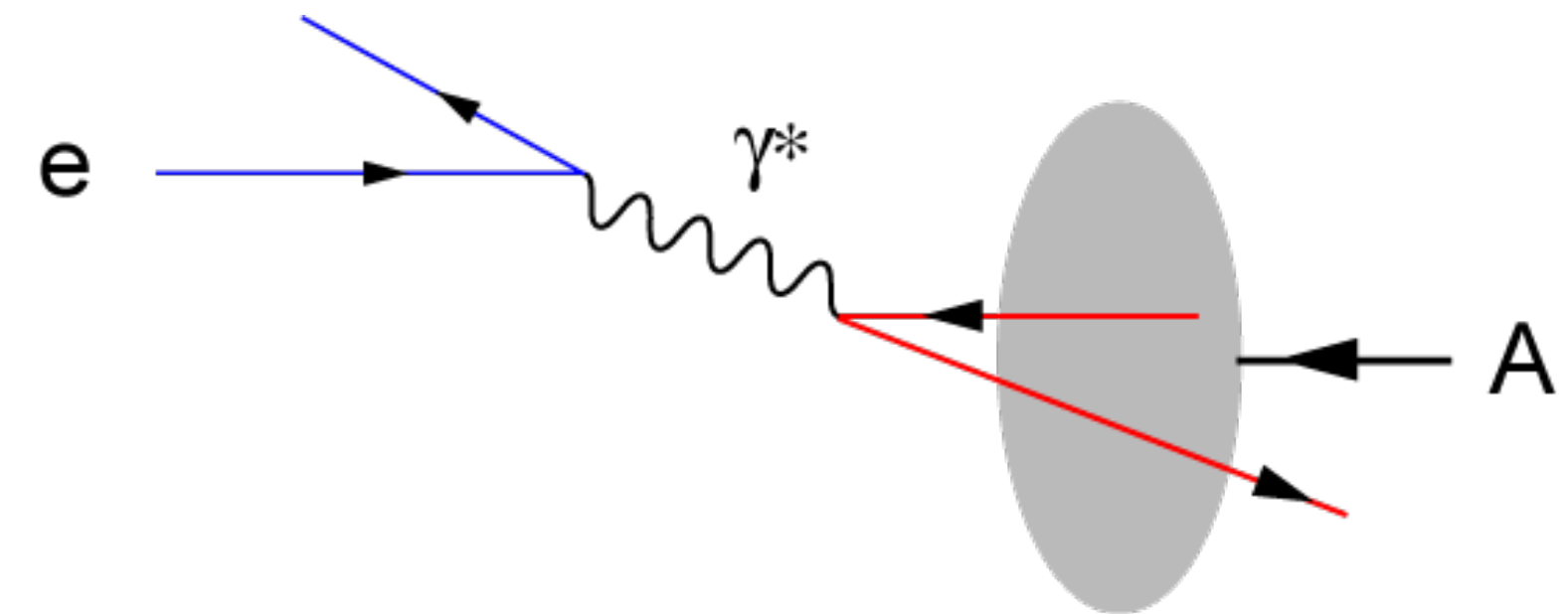

- Explore QCD & Hadron Structure
- Indirect access to glue
- High precision & access to partonic kinematics

Both are **complementary** and provide excellent information on properties of gluons in the nuclear wave functions

**Precision measurements**  $\Rightarrow$  **DIS** due to unprecedented exact knowledge of QED

# General: Category of Processes to Study

DIS event kinematics - scattered electron or final state particles (CC DIS, low  $y$ )

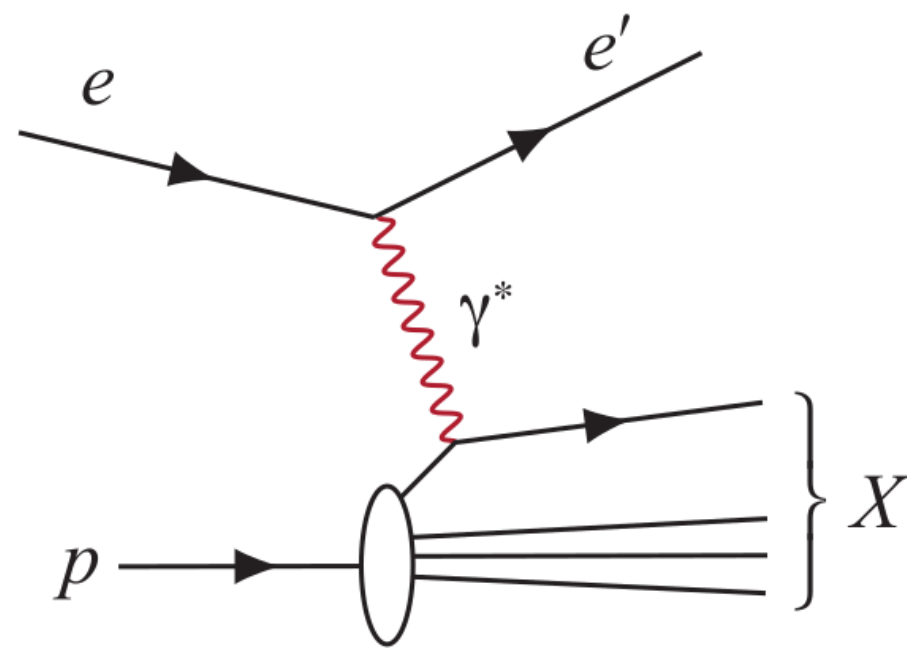

## Neutral Current DIS

- Detection of **scattered electron** with high precision - event kinematics

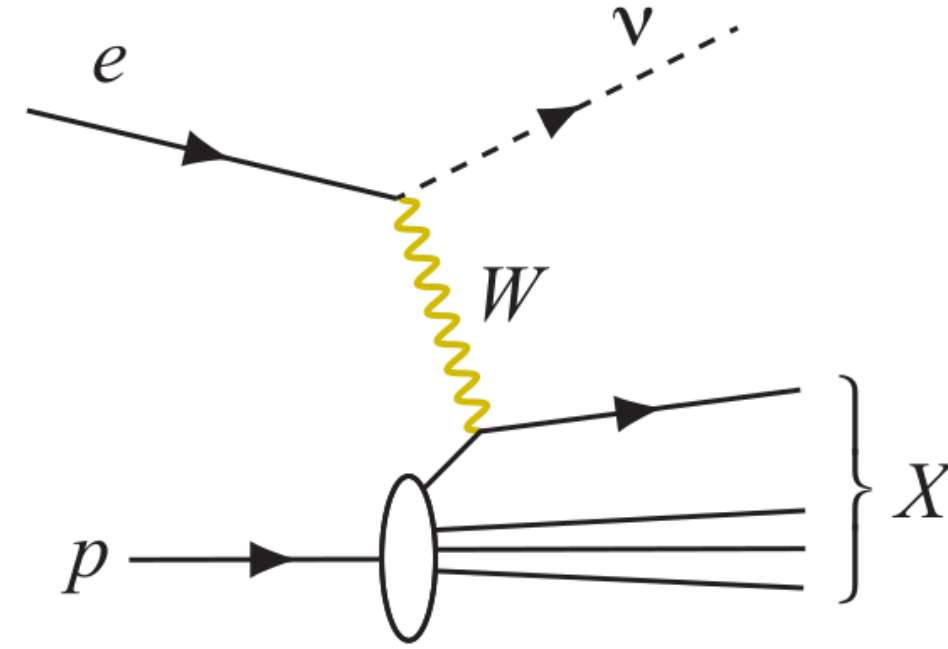

## Charged Current DIS

- Event kinematics from the **final state particles** (Jacquet-Blondel method)

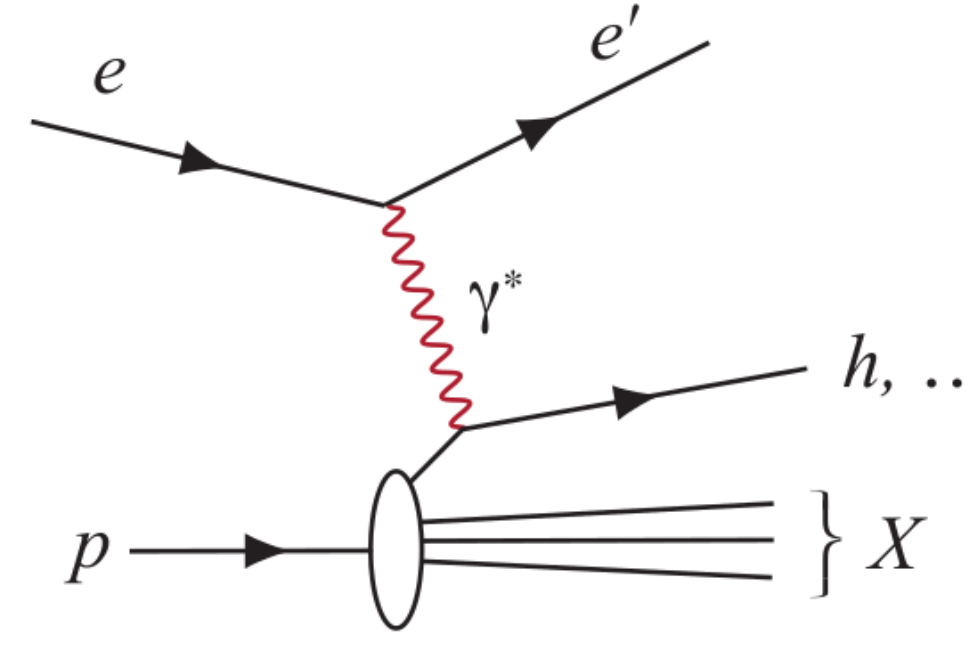

## Semi-Inclusive DIS

- Precise detection of **scattered electron** in coincidence with at least 1 hadron

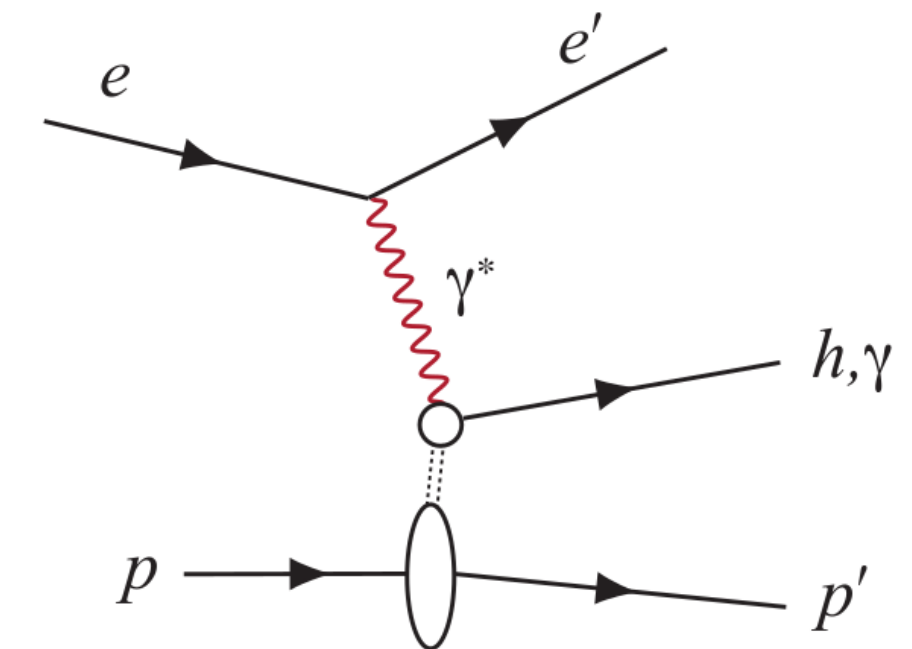

## Deep Exclusive Processes

- Detection of **all particles** in event

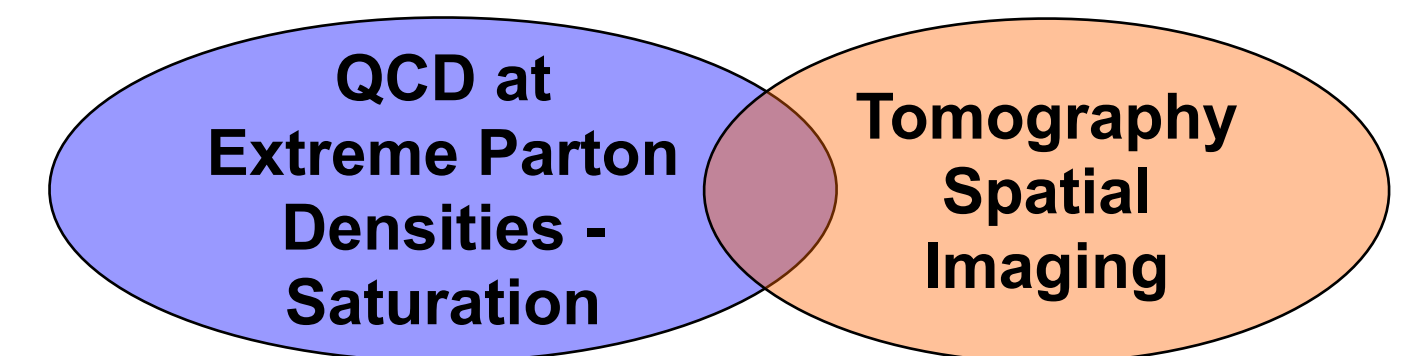
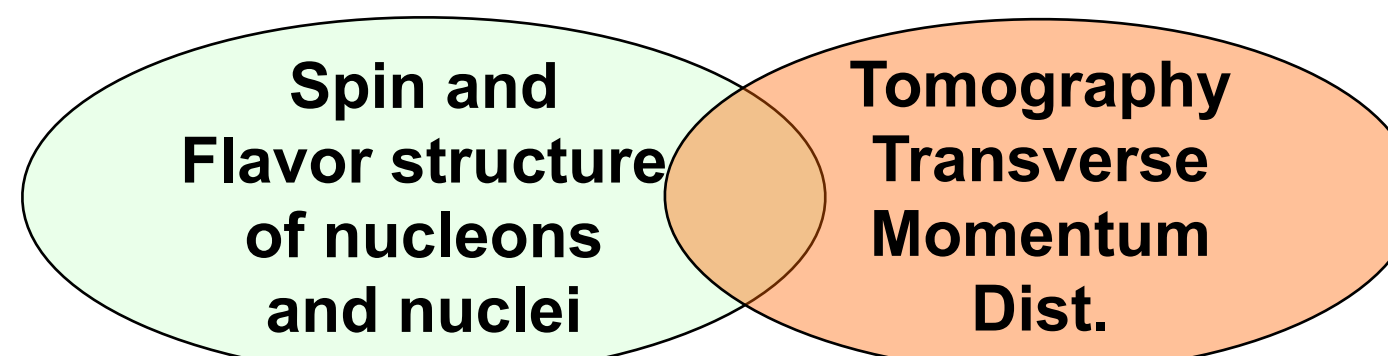
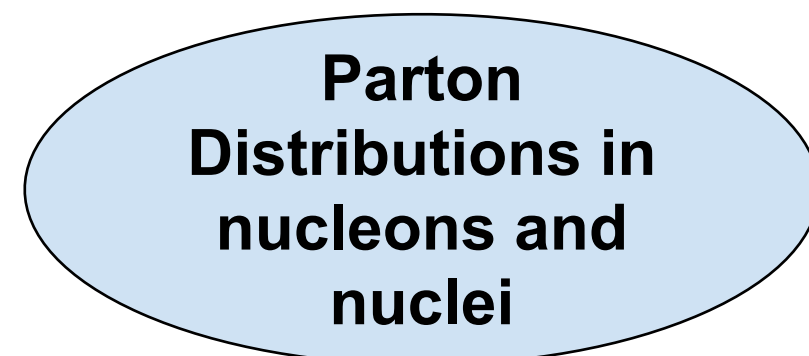

# What Else?

- ▶ Access to gluon dominated region and wide kinematic range in  $x$  and  $Q^2$ 
  - ➔ Large center-of-mass energy range  $\sqrt{s} = 20 - 14000$  GeV
- ▶ Access to spin structure and 3D spatial and momentum structure
  - ➔ Polarized electron and proton and light nuclear beams  $\geq 70\%$  for both
- ▶ Accessing the highest gluon densities ( $Q_s^2 \sim A^{1/3}$ )
  - ➔ Nuclear beams, the heavier the better (up to U)
- ▶ Studying observables as a fct. of  $x$ ,  $Q^2$ ,  $A$ , etc.
  - ➔ High luminosity (100x HERA):  $10^{33-34} \text{ cm}^{-2} \text{ s}^{-1}$

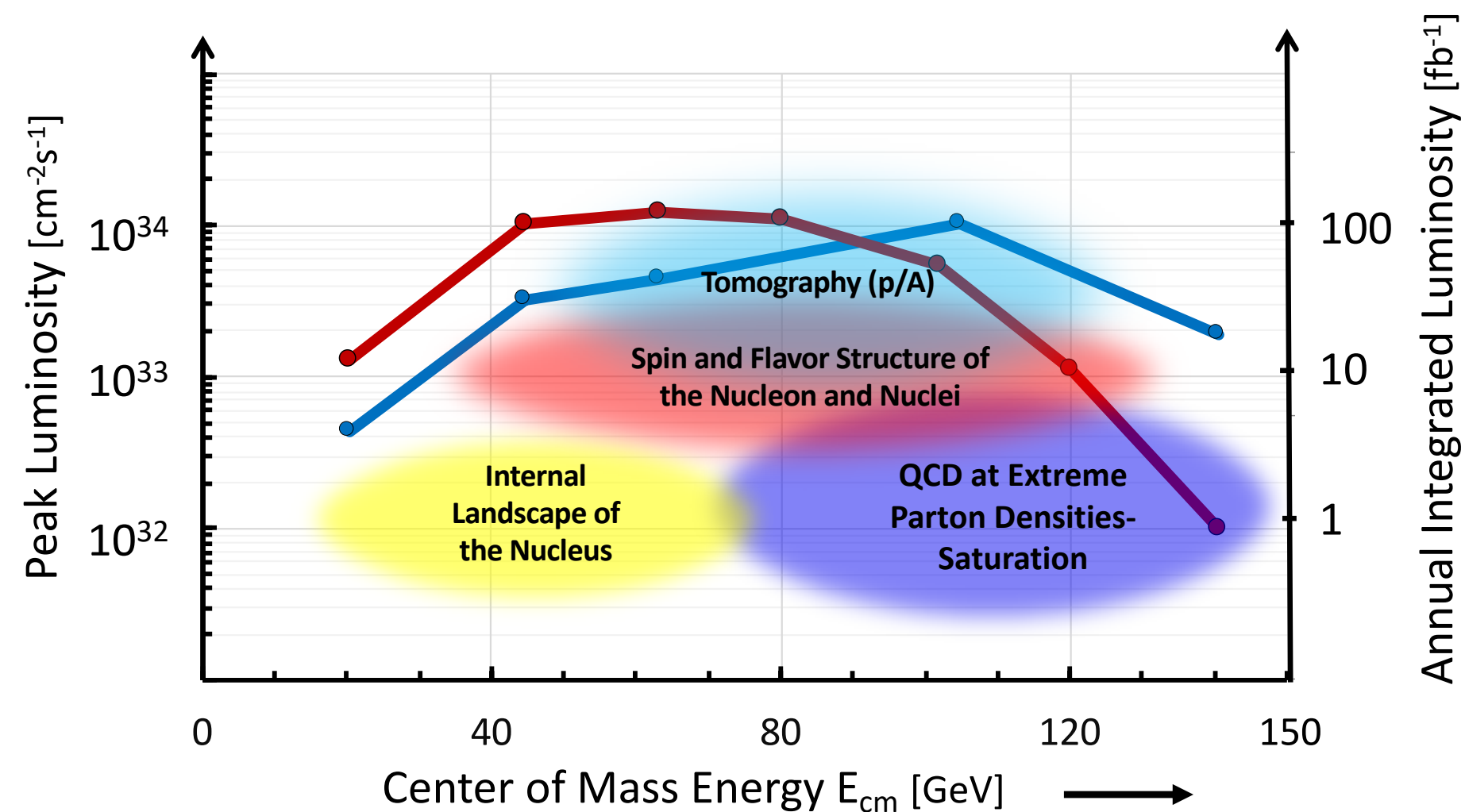

HERA@DESY



Siberian Snakes, RHIC

# Reality Check

---

Designing a dream machine is easy but

- It has to be fundable
- The technology has to be available
- Path of failed efforts is long: Isabelle, SSC, ...

Find the parameters that do the job and that actually can be realized!

EIC:

- Highly polarized (70%) e- and p beams
- Ion beams from D to U
- Variable center-of-mass energies from  $\sqrt{s}=20-140$  GeV
- High collision luminosity  $10^{33-34}$  cm<sup>-2</sup>s<sup>-1</sup> (HERA  $\sim 10^{31}$ )
- Possibilities of having more than one interaction region

# Landscape of DIS: The Uniqueness of EIC

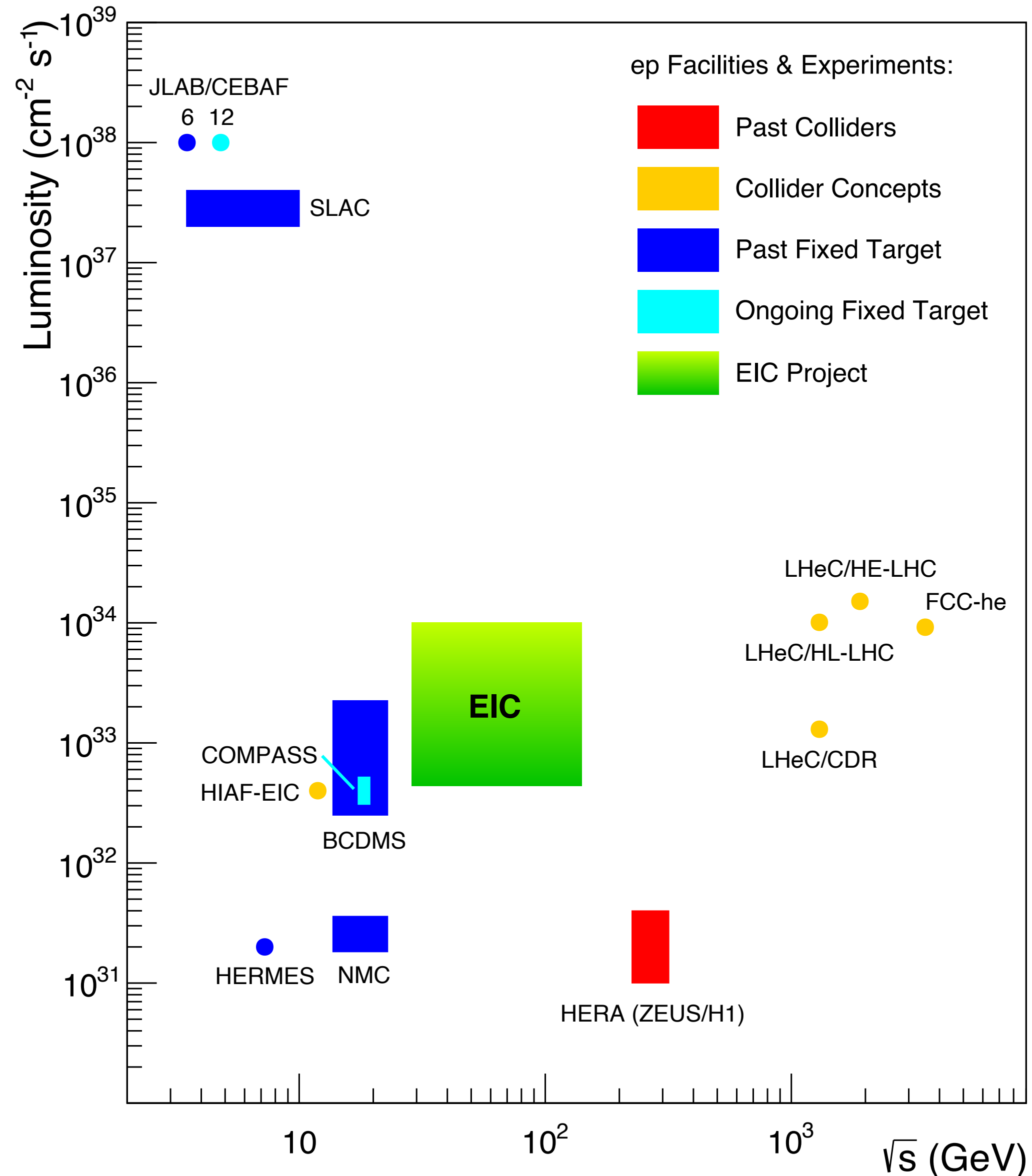

- EIC cannot compete with e+p at HERA ( $\sqrt{s} = 318 \text{ GeV}$ )
- EIC's strength is polarized  $e\uparrow+p\uparrow$  and e+A collisions
- Here the kinematic reach extends substantially compared to past (fixed target) coverage
  - ▶  $Q^2 \times 20, x/20$  for e+A
  - ▶  $Q^2 \times 20, x/100$  for polarized  $e\uparrow+p\uparrow$

# Landscape of DIS: The Uniqueness of EIC

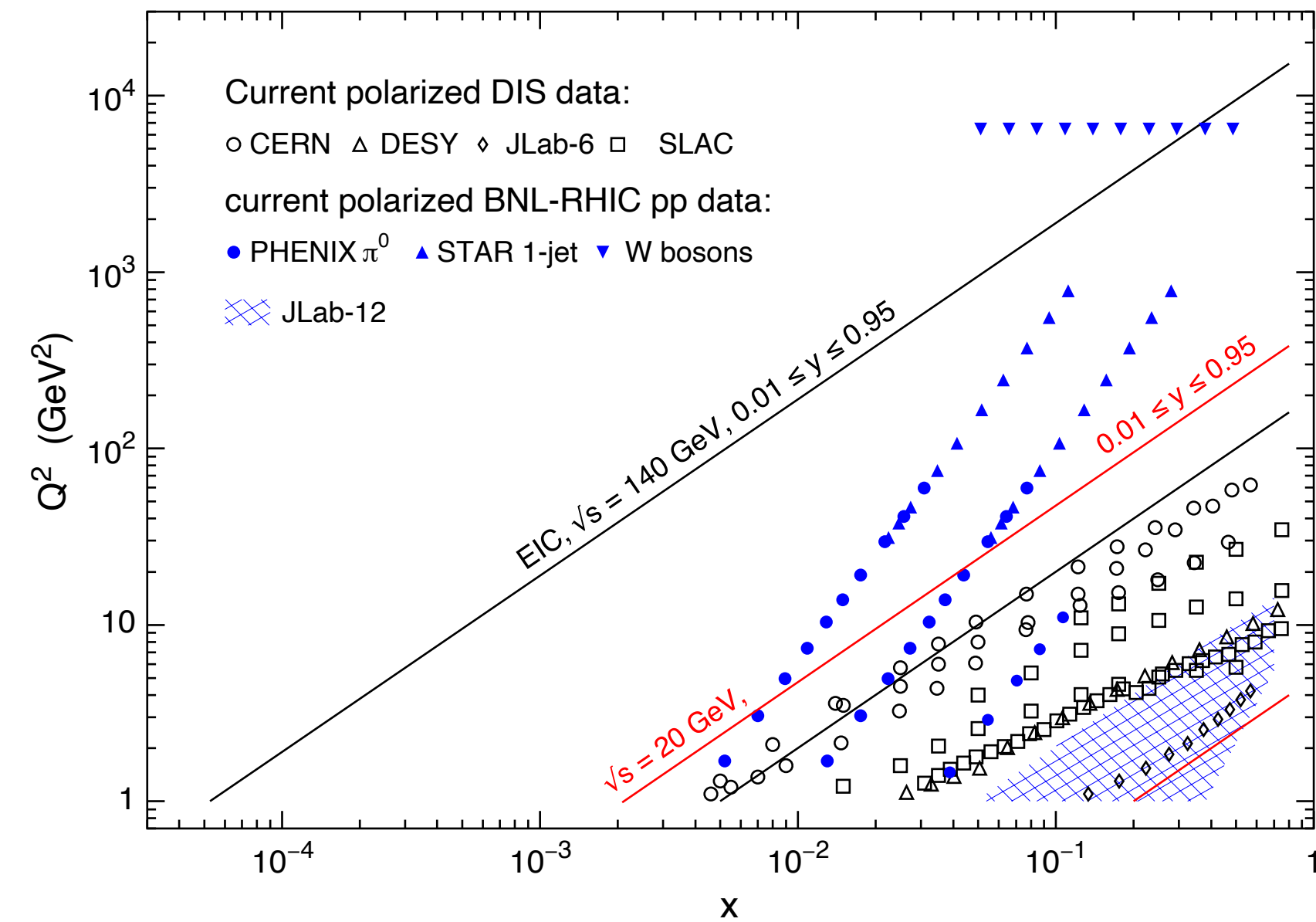

- EIC cannot compete with e+p at HERA ( $\sqrt{s} = 318 \text{ GeV}$ )
- EIC's strength is polarized  $e\uparrow+p\uparrow$  and e+A collisions
- Here the kinematic reach extends substantially compared to past (fixed target) coverage
  - ▶  $Q^2 \times 20, x/20$  for e+A
  - ▶  $Q^2 \times 20, x/100$  for polarized  $e\uparrow+p\uparrow$

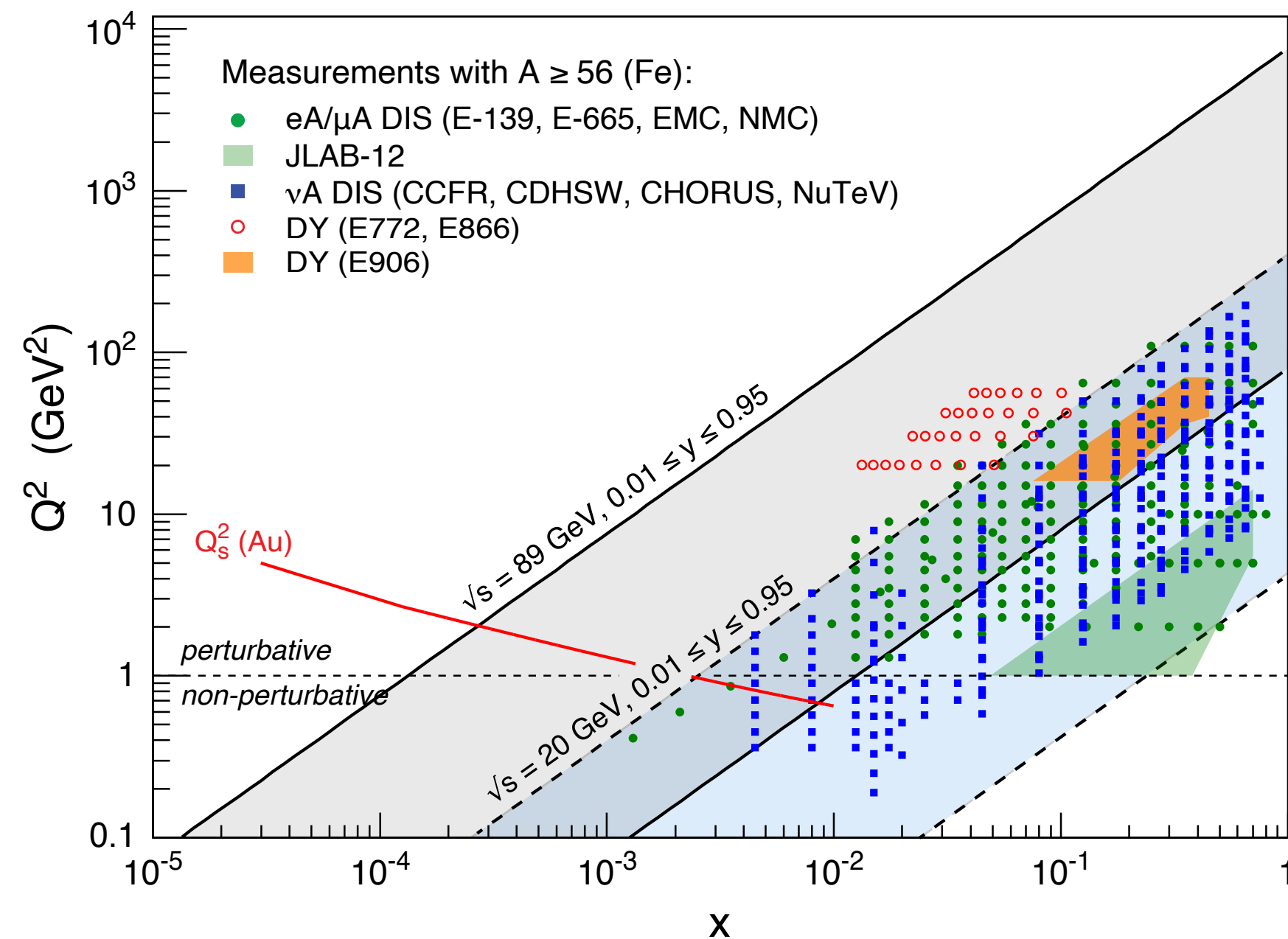

# Status of EIC

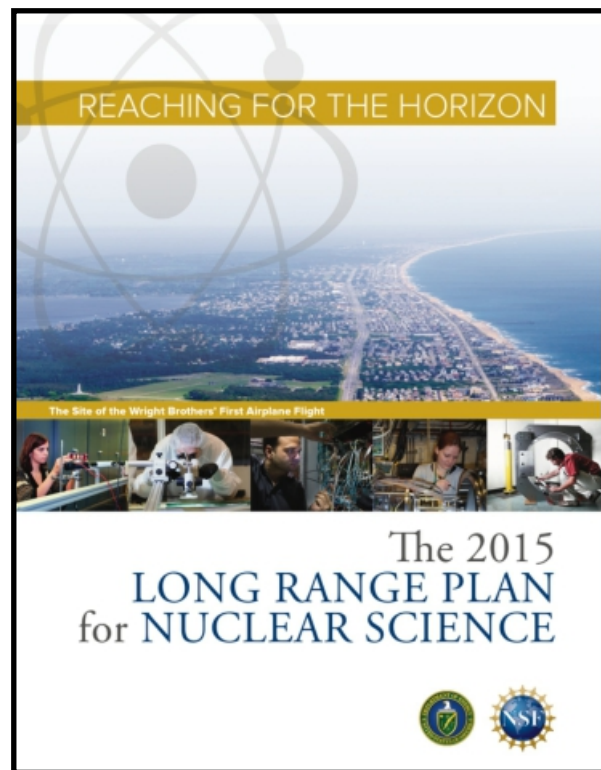

2015: US Nuclear Physics Long Range Plan:  
“We recommend a high-energy high-luminosity polarized EIC as the highest priority for new facility construction following the completion of FRIB.”

2018: National Academy EIC Review  
“The committee finds that the science that can be addressed by an EIC is compelling, fundamental and timely.”

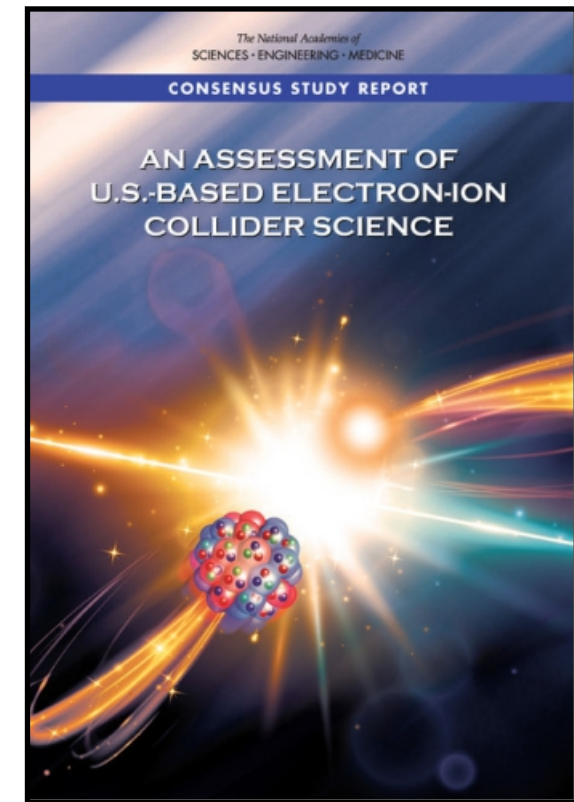

December 2019/January 2020:  
After science, cost, and host review DoE gives EIC CD-0 (*Approve Mission Need*) and selects BNL as the hosting site. BNL and JLab are the hosting labs. Project management officially started 4/1/2020.

January/February 2021: Release of CDR, CD-1 Review

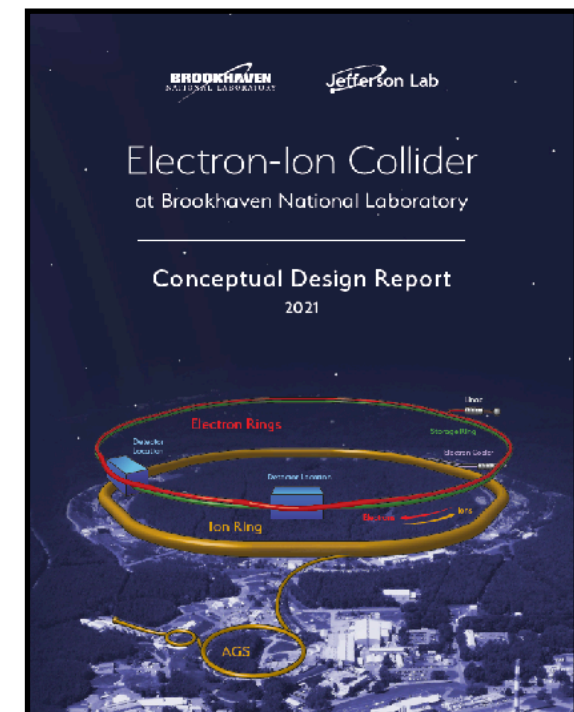

July 2021: CD-1 (*Approve Alternative Selection and Cost Range*) received.

Original cost estimate: \$2 - 2.6 B  
\$100M from New York State towards infrastructure



April 2024: EIC project passes CD-3A for Long-Lead Procurements

# EIC Machine Overview

---

EIC is using part of RHIC facility at BNL which is operating at its peak



# EIC Machine Overview

EIC is using part of RHIC facility at BNL which is operating at its peak

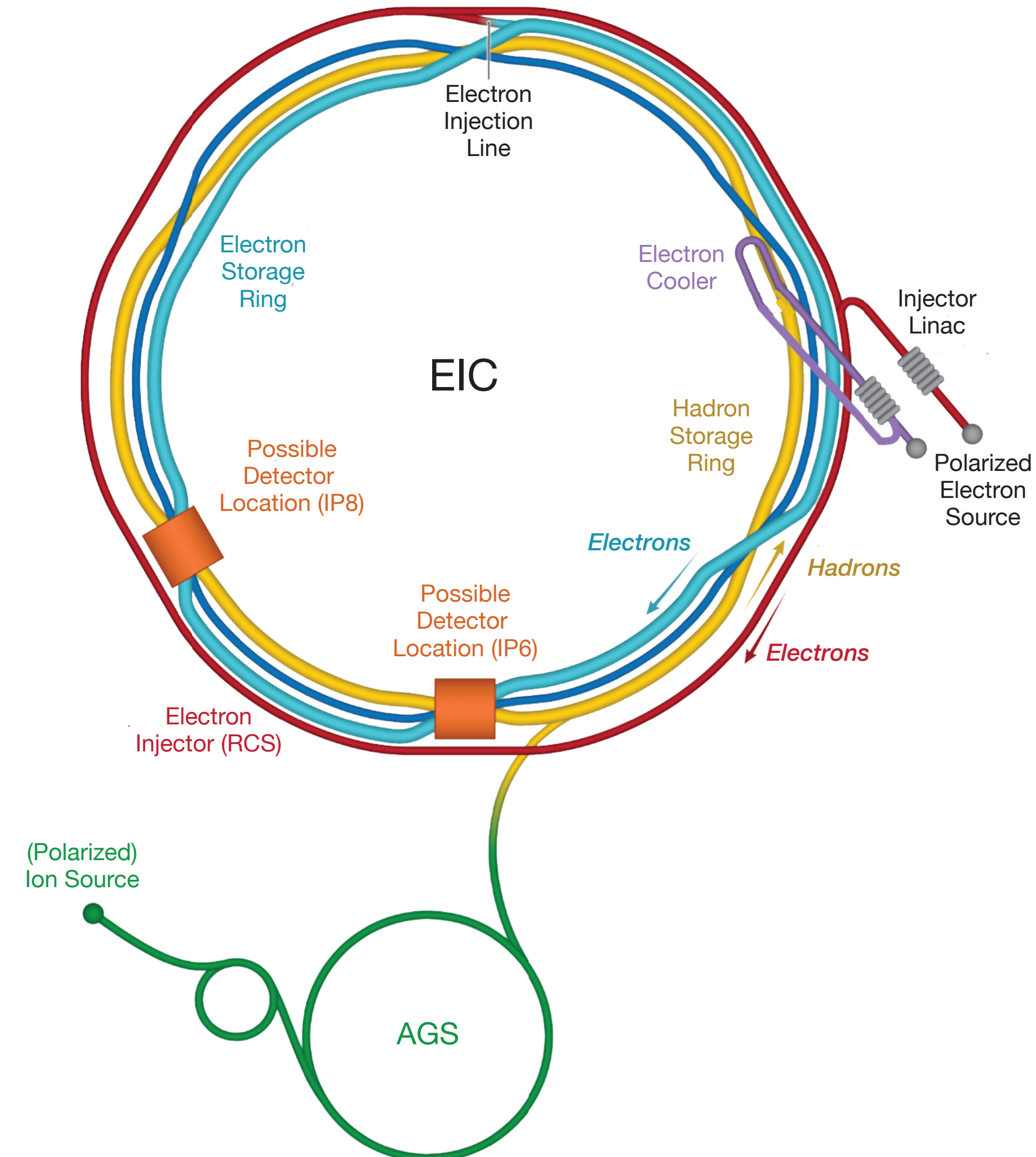
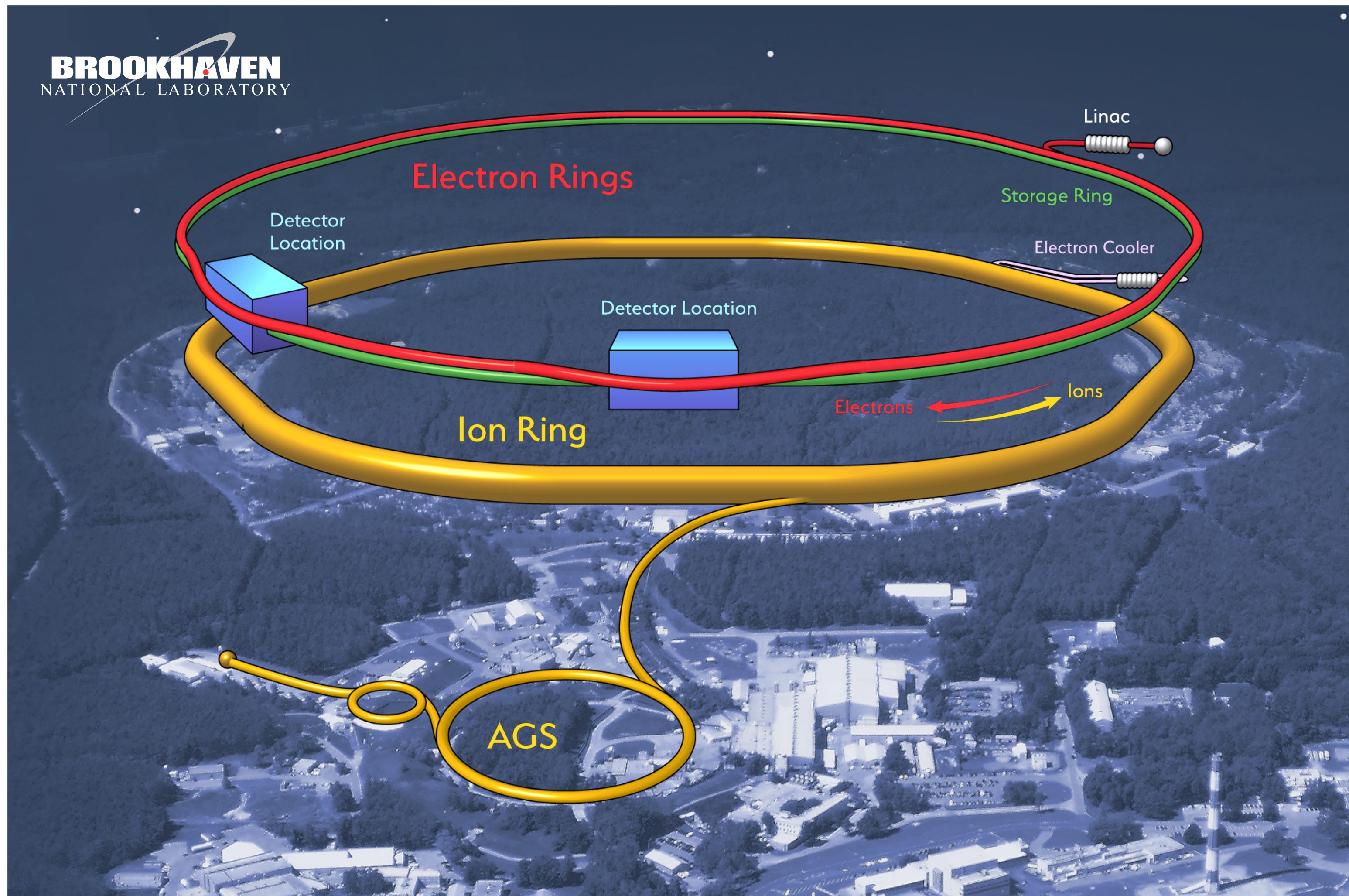

# EIC Machine Overview

EIC is using part of RHIC facility at BNL which is operating at its peak

## Three Ring Design

- Hadron storage ring 40-275 GeV (**existing**)
  - ▶ Many bunches, 1160 @ 1A beam current
  - ▶ Need strong cooling
- Electron rapid cycling synchrotron (**new**)
  - ▶ 1-2 Hz
  - ▶ Spin transparent due to high periodicity
- Electron storage ring (2.5–18 GeV, **new**)
  - ▶ Many bunches
  - ▶ Large beam current (2.5 A) → 10 MW S.R. power
  - ▶ S.C. RF cavities
- High luminosity interaction region(s) (**new**)
  - $L = 10^{34} \text{cm}^{-2}\text{s}^{-1}$
  - Superconducting magnets
  - 25 mrad crossing angle with crab cavities

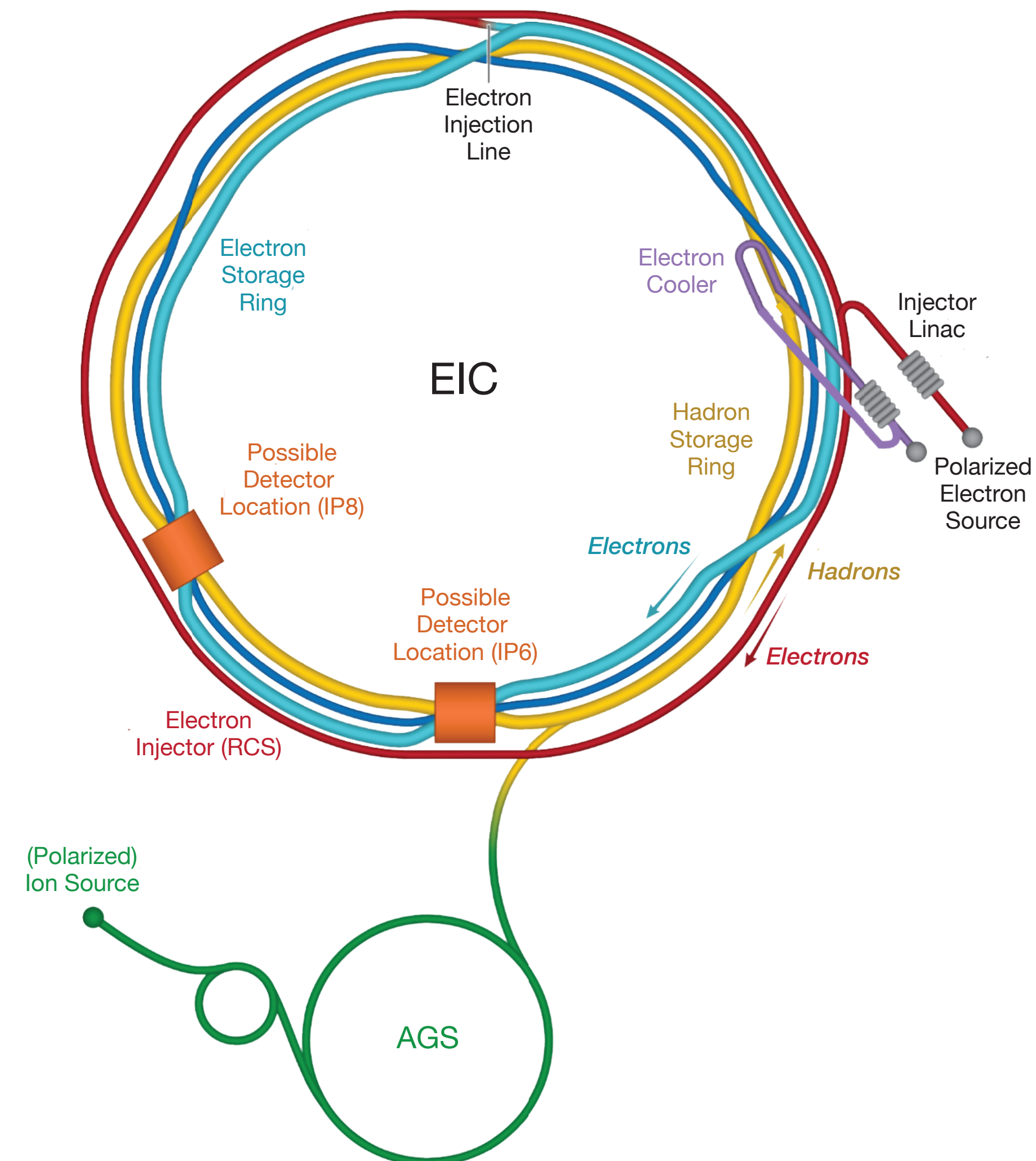

# EIC IR Layout

## High luminosity:

- 25 mrad crossing angle
- Small  $\beta^*$  for high luminosity with limited IR chromaticity contributions
- Large final focus quadrupole aperture

## Machine Detector Interface

- Large detector acceptance
- Forward spectrometer
- No magnets within - 4.5 / +5 m from IP
- Space for luminosity detector, neutron detector, "Roman Pots"

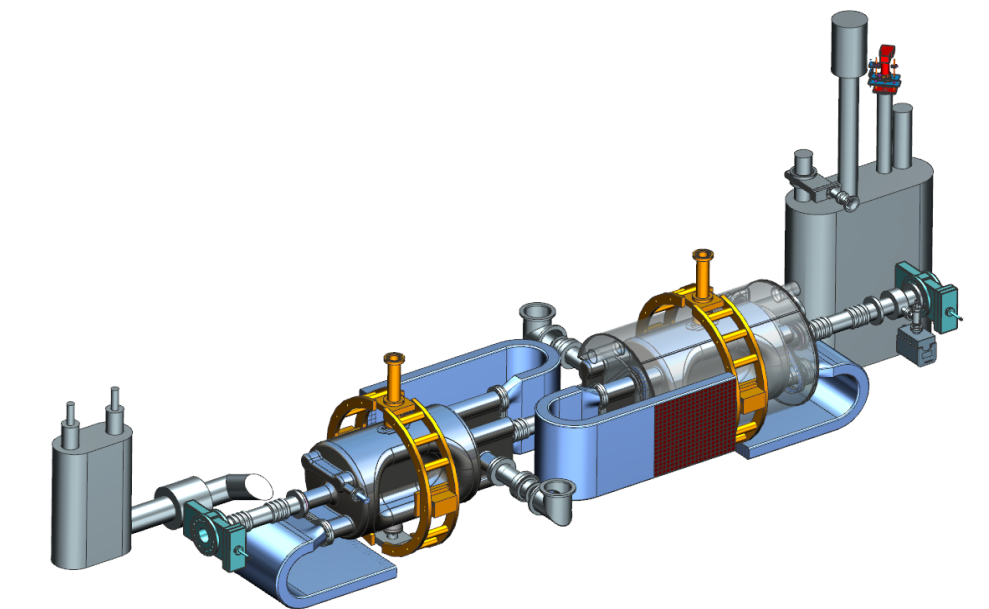
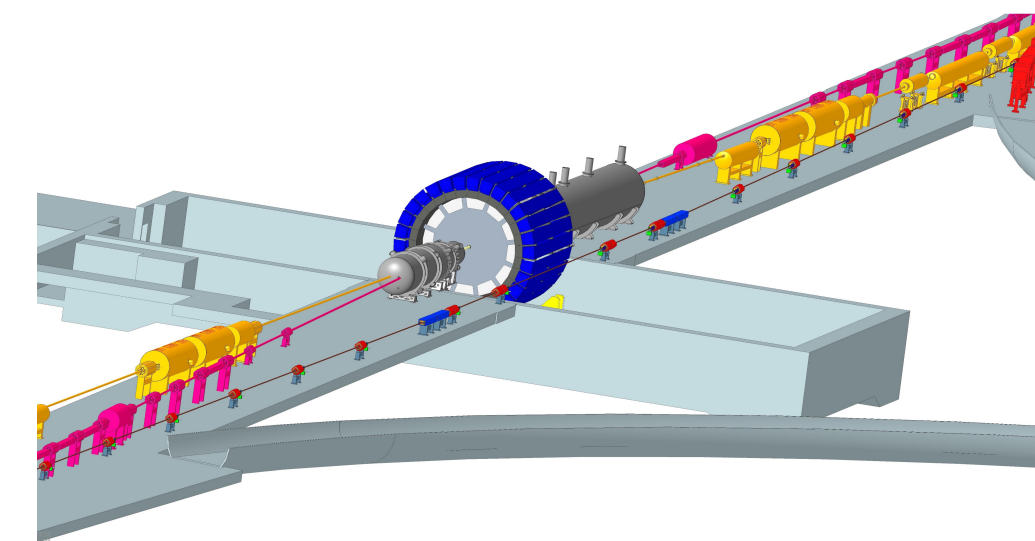
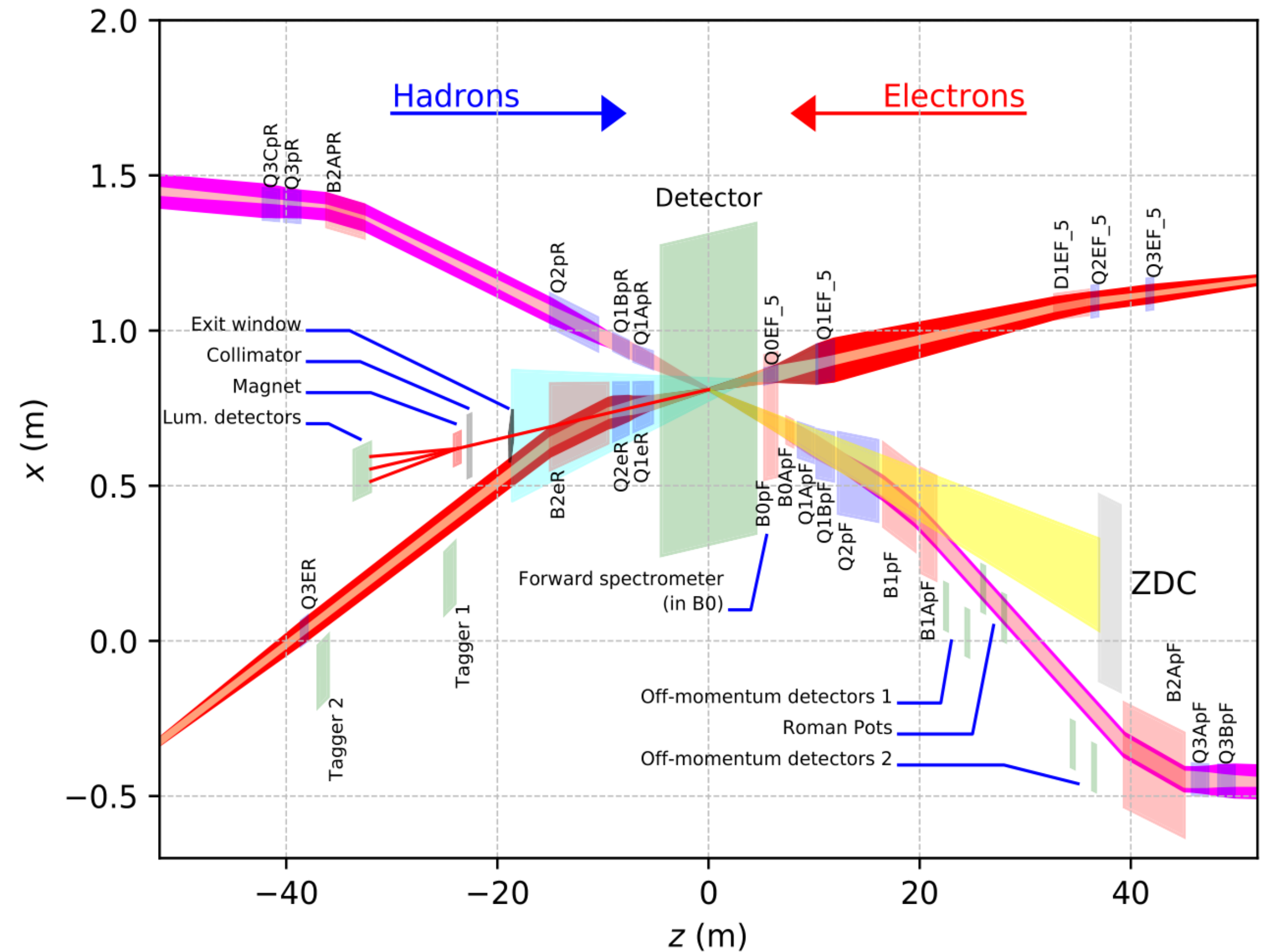
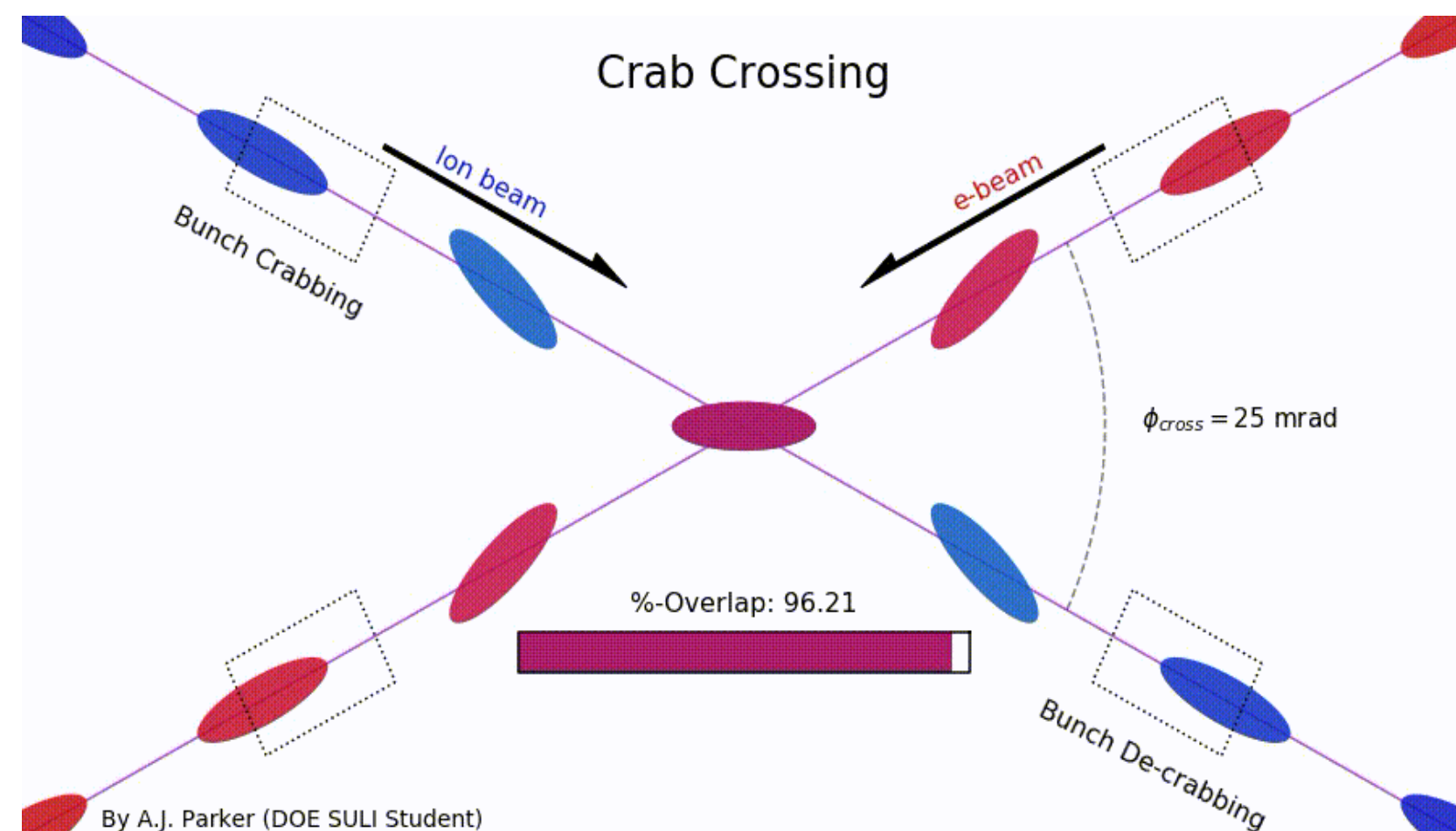

# EIC IR Layout

## High luminosity:

- 25 mrad crossing angle
- Small  $\beta^*$  for high luminosity with limited IR chromaticity contributions
- Large final focus quadrupole aperture

## Machine Detector Interface

- Large detector acceptance
- Forward spectrometer
- No magnets within - 4.5 / +5 m from IP
- Space for luminosity detector, neutron detector, "Roman Pots"

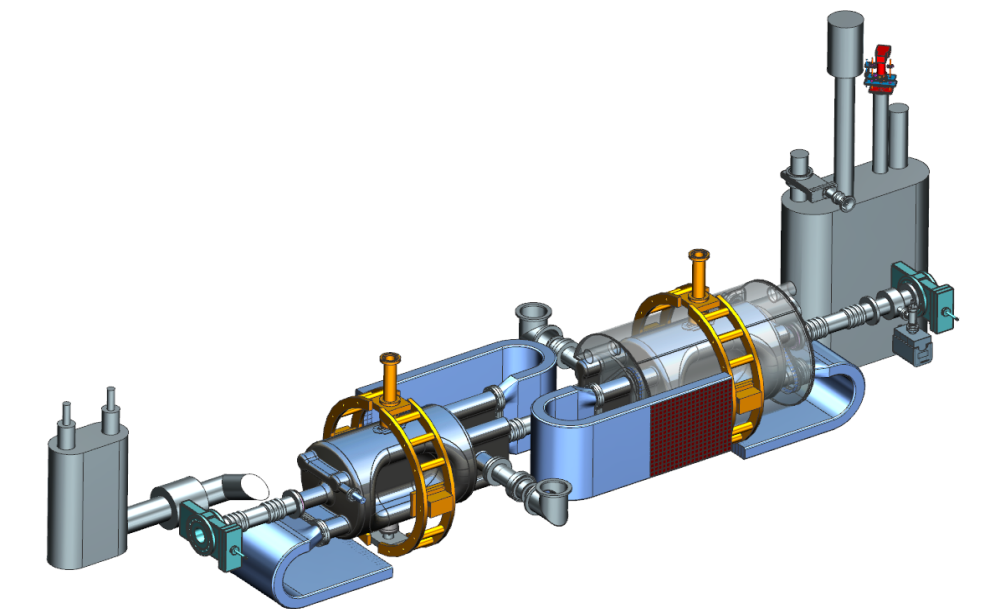
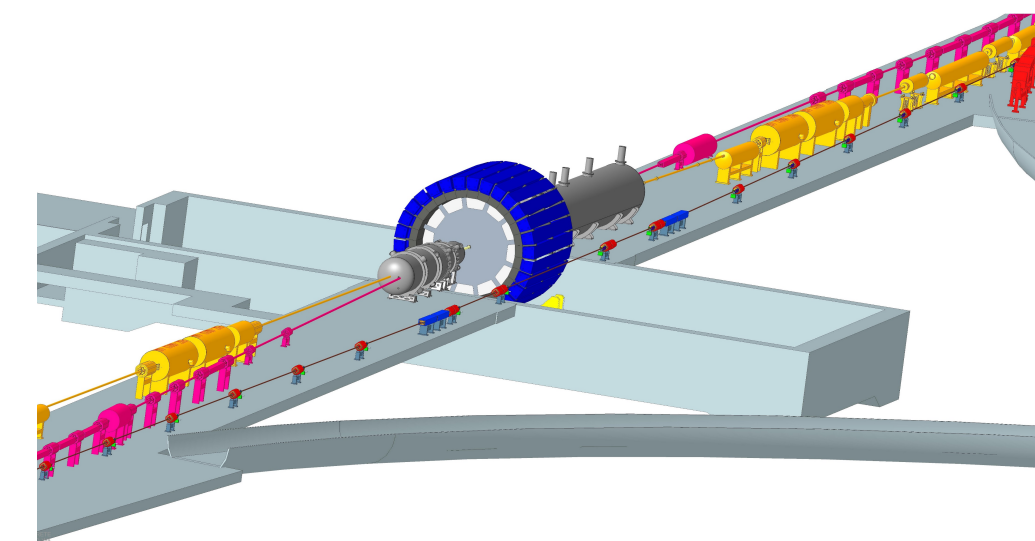
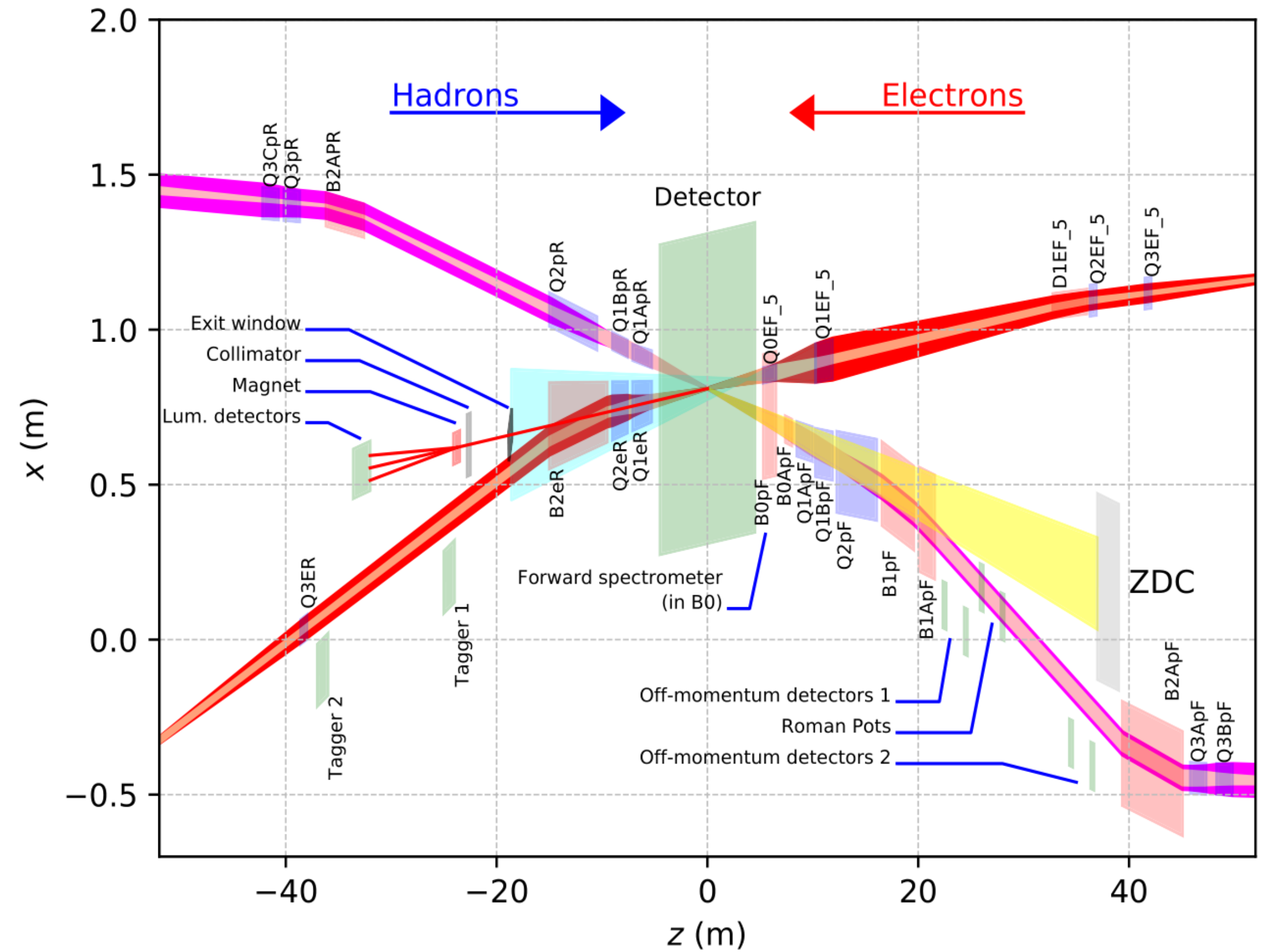
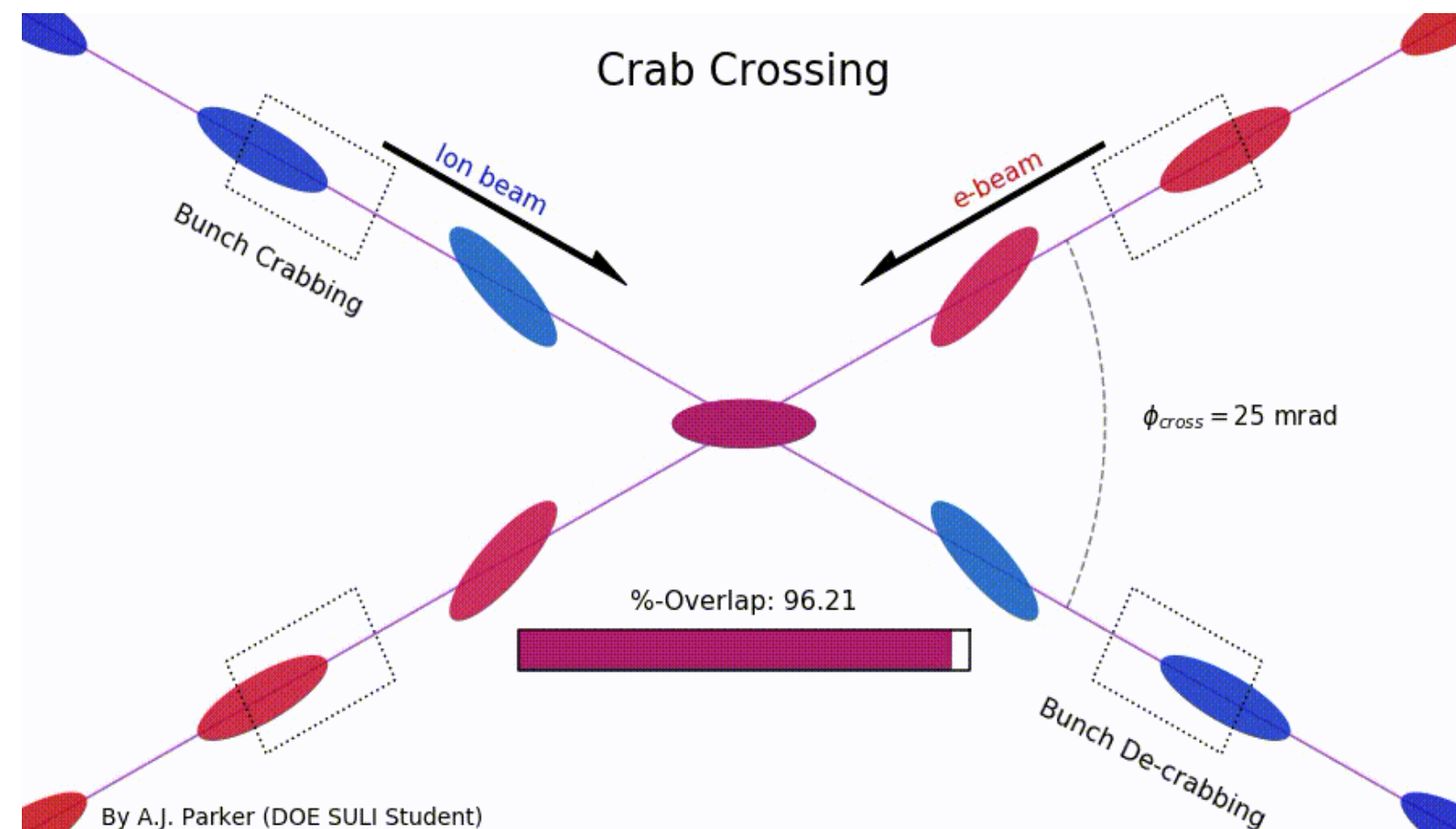

# e+p Luminosity versus Center-of-Mass Energy

EIC peak luminosities (CDR)

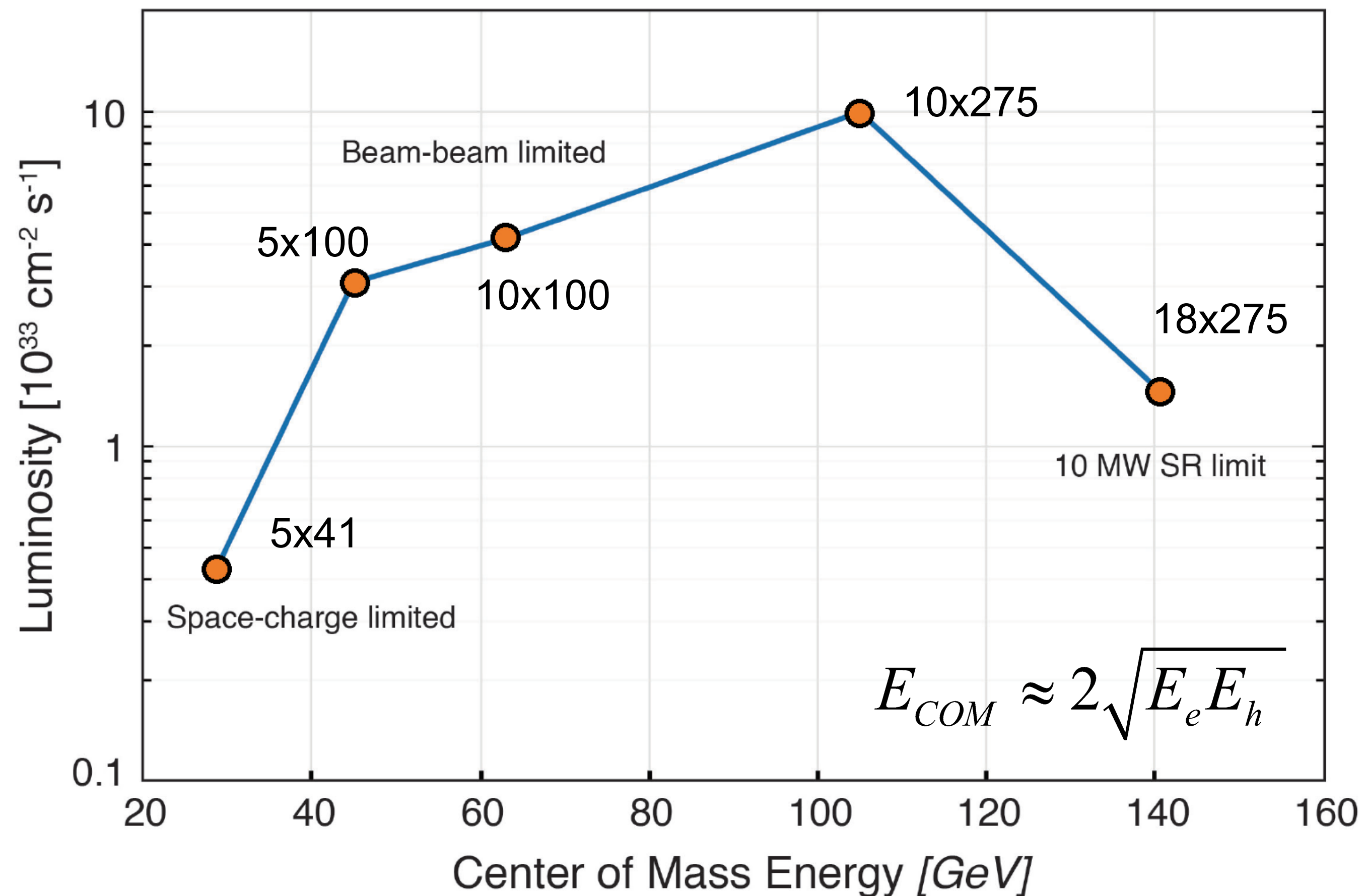

- Planning of beam use will be critical to increase physics output
  - ▶ Balance:  $\mathcal{L}, \sqrt{s}, A$
- Electron-nucleon luminosities in e-A collisions are similar within a factor of 2 to 3

Recall in pp colliders:  $\mathcal{L} \propto \sqrt{s}$

# Detector Planning

- The DOE-NP supported EIC Project includes **one** detector and **one** IR in the reference costing
- The EIC is capable of supporting a science program that includes **two** detectors and **two** interaction regions.
- The community (EIC User Group) is strongly in favor of two general purpose detectors
  - ▶ Complementarity, cross-checking, cross-calibration/reduction of systematics (see HERA), mitigating of overall risk
- **EIC User Group “Yellow Report” Effort**
  - ▶ Initiative to advance the state and detail of requirements and detector concepts in preparation for the realization of the EIC.
  - ▶ 1 year effort concluded in March 2021 with a comprehensive “Yellow” Report
  - ▶ 902 Pages, 414 authors from 121 institutions, 675 figures
  - ▶ Nucl. Phys. A 1026 (2022) 122447, arXiv:2103.05419

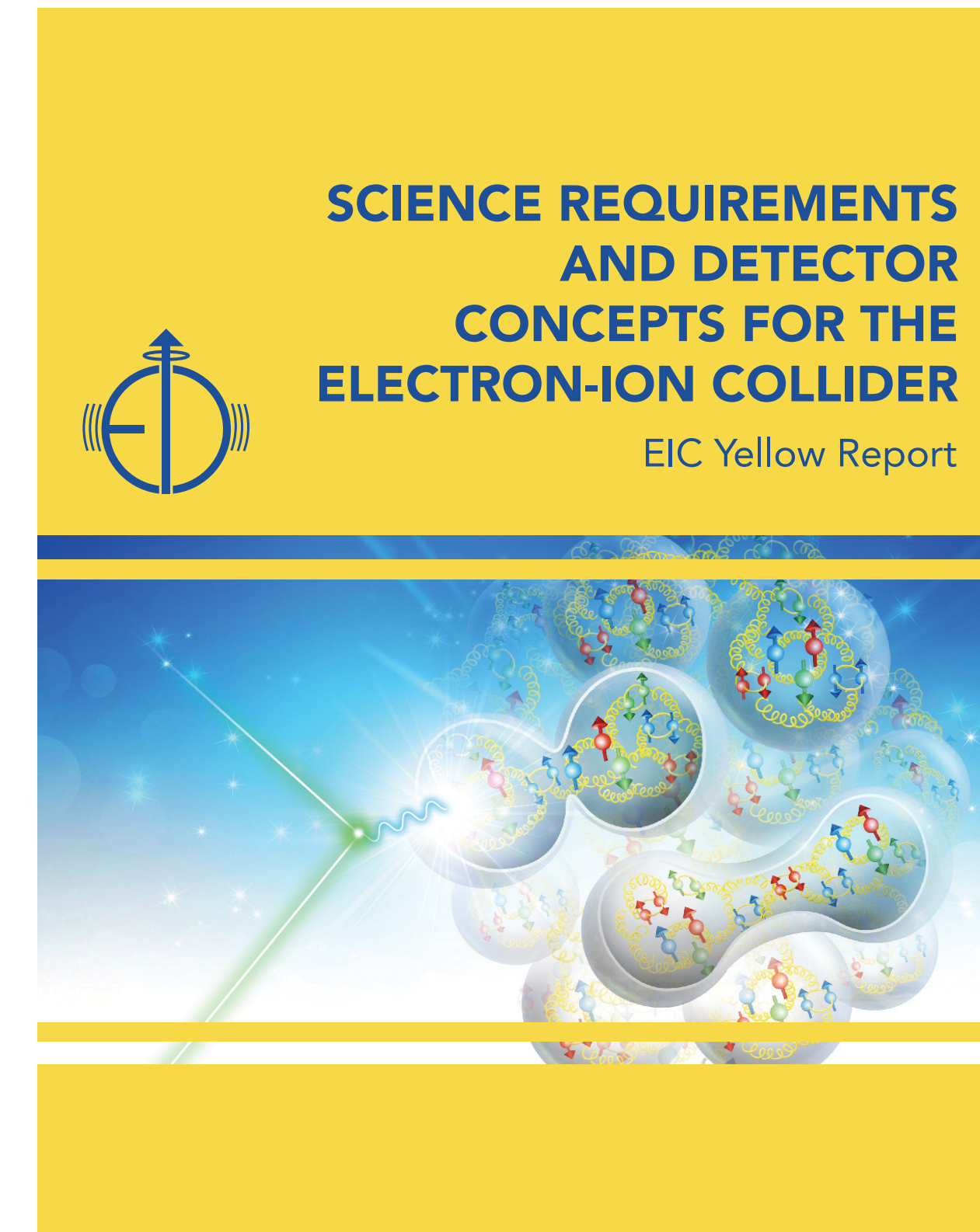

η	Nomenclature	Tracking					Electrons and Photons				ν/Kp		HCAL		Muons	
		Resolution	Relative Momentum	Allowed XZ <sub>rms</sub>	Minimum p <sub>T</sub> (MeV/c)	Transverse Pointing Res.	Longitudinal Pointing Res.	Resolution	PID	Min E Photon	p-Range	Separation	Resolution	Energy		
-4.6	Low-Z2 tagger	Not Accessible														
4.6 to 4.0	Backward Detector	Reduced Performance														
4.0 to 3.5		Not Accessible														
3.5 to 3.0		Not Accessible														
3.0 to 2.5		Not Accessible														
2.5 to 2.0		Not Accessible														
2.0 to 1.5		Not Accessible														
1.5 to 1.0	Barrel	Not Accessible														
1.0 to 0.5		Not Accessible														
0.5 to 0.0		Not Accessible														
0.0 to 0.5		Not Accessible														
0.5 to 1.0	Forward Detectors	Reduced Performance														
1.0 to 1.5		Not Accessible														
1.5 to 2.0		Not Accessible														
2.0 to 2.5		Not Accessible														
2.5 to 3.0		Not Accessible														
3.0 to 3.5		Not Accessible														
3.5 to 4.0	Instrumentation to separate charged particles from photons	Reduced Performance														
4.0 to 4.5	Not Accessible															
4.6	Proton Spectrometer Zero Degree Neutral Detection	Not Accessible														

# Inclusive (All): Scattered Electron Requirements

The energy and angle of scatter electron gives key variables  $x, y, Q^2$

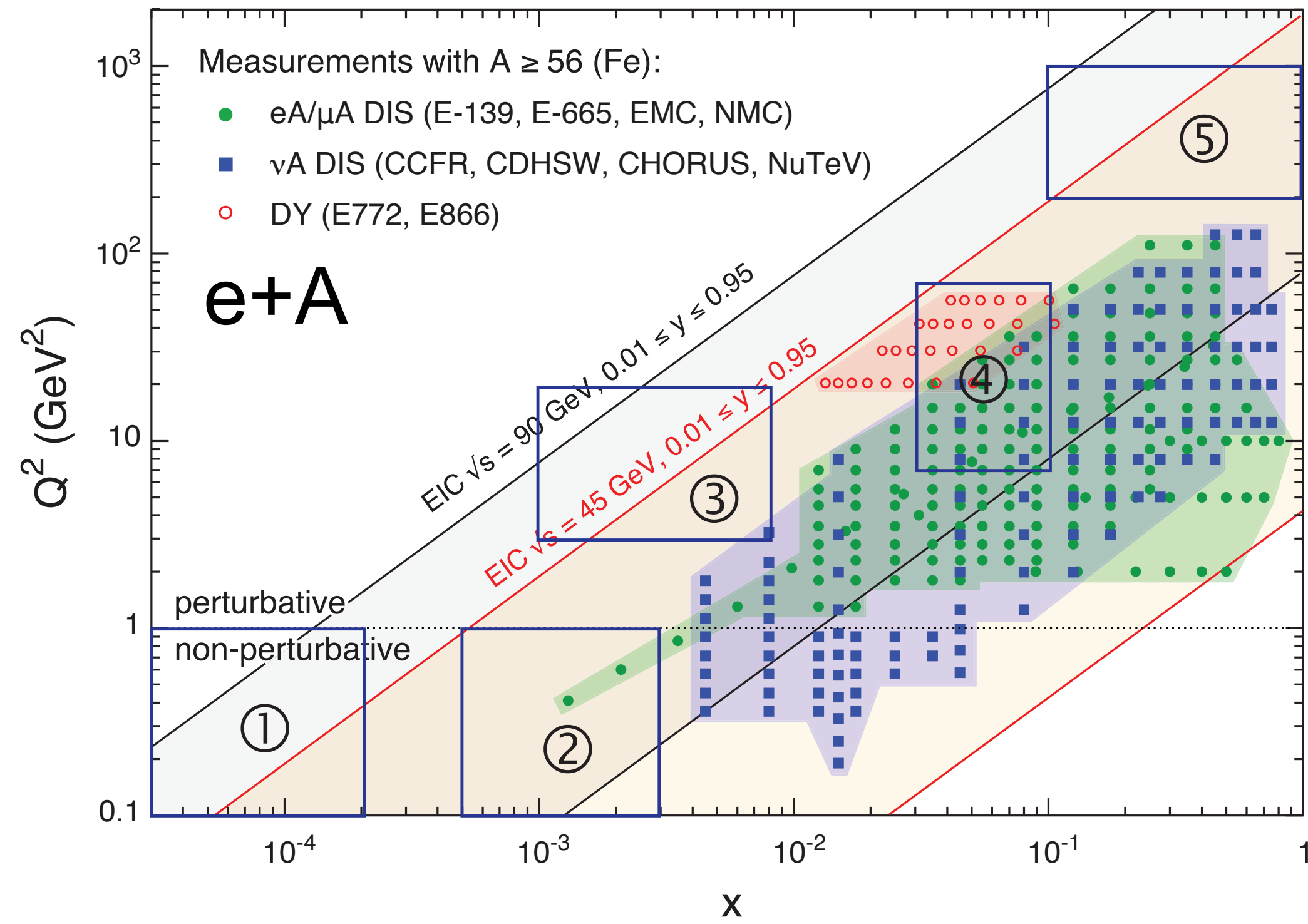

# Inclusive (All): Scattered Electron Requirements

The energy and angle of scatter electron gives key variables  $x, y, Q^2$

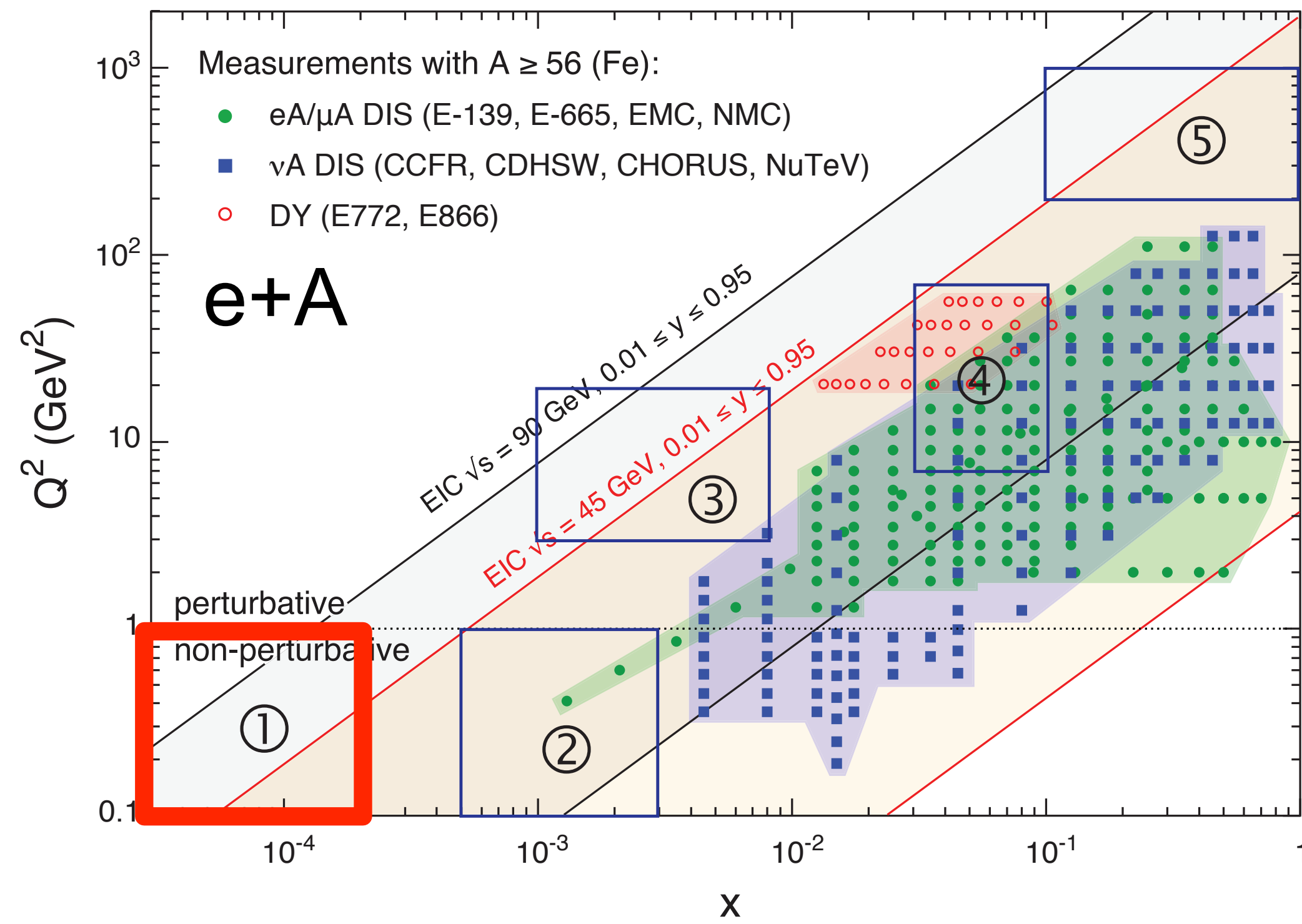

20 GeV on 100 GeV,  $0.1 < Q^2 < 1$  GeV<sup>2</sup>,  $3 \cdot 10^{-5} < x < 2 \cdot 10^{-4}$

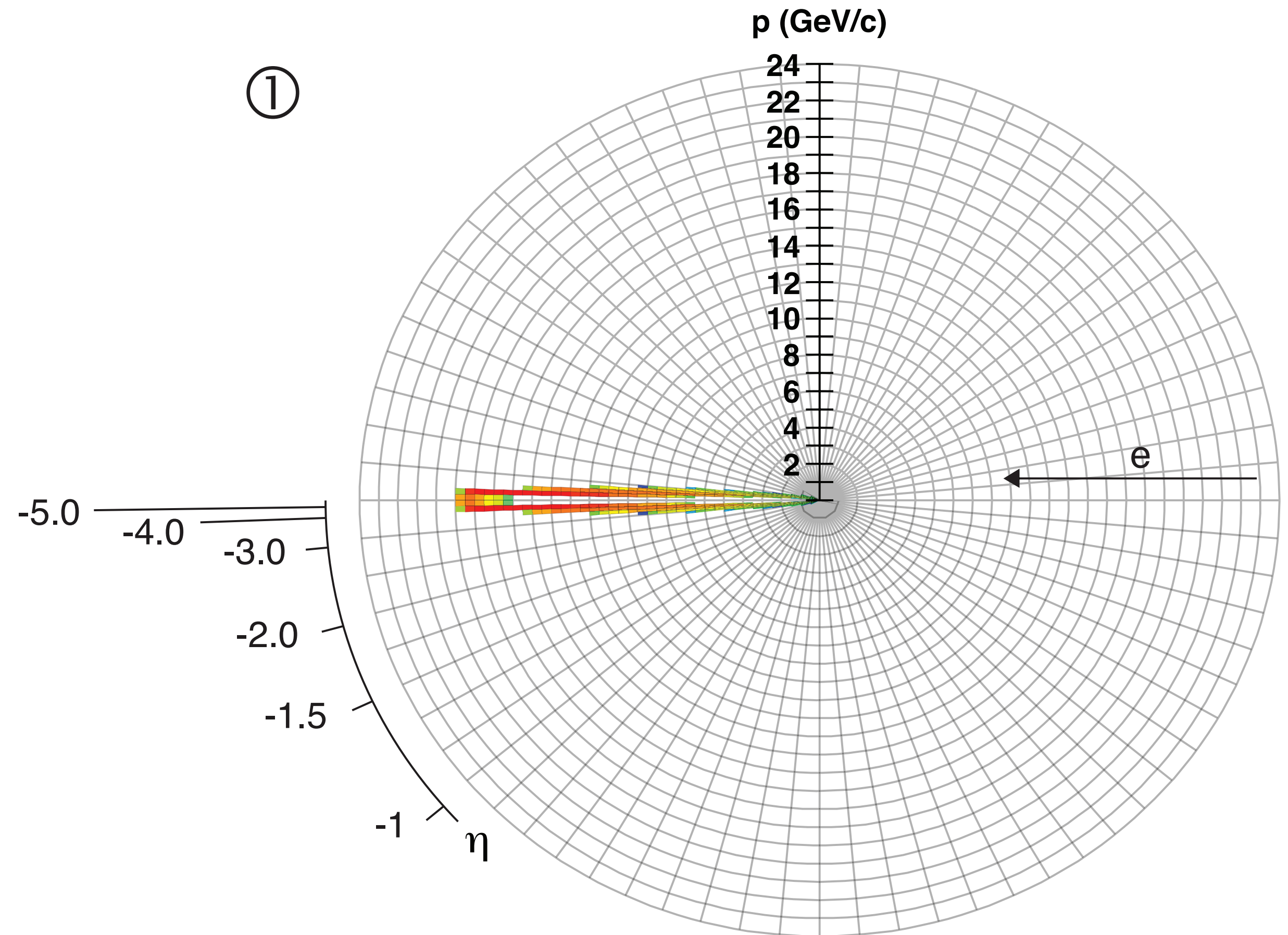

# Inclusive (All): Scattered Electron Requirements

The energy and angle of scatter electron gives key variables  $x, y, Q^2$

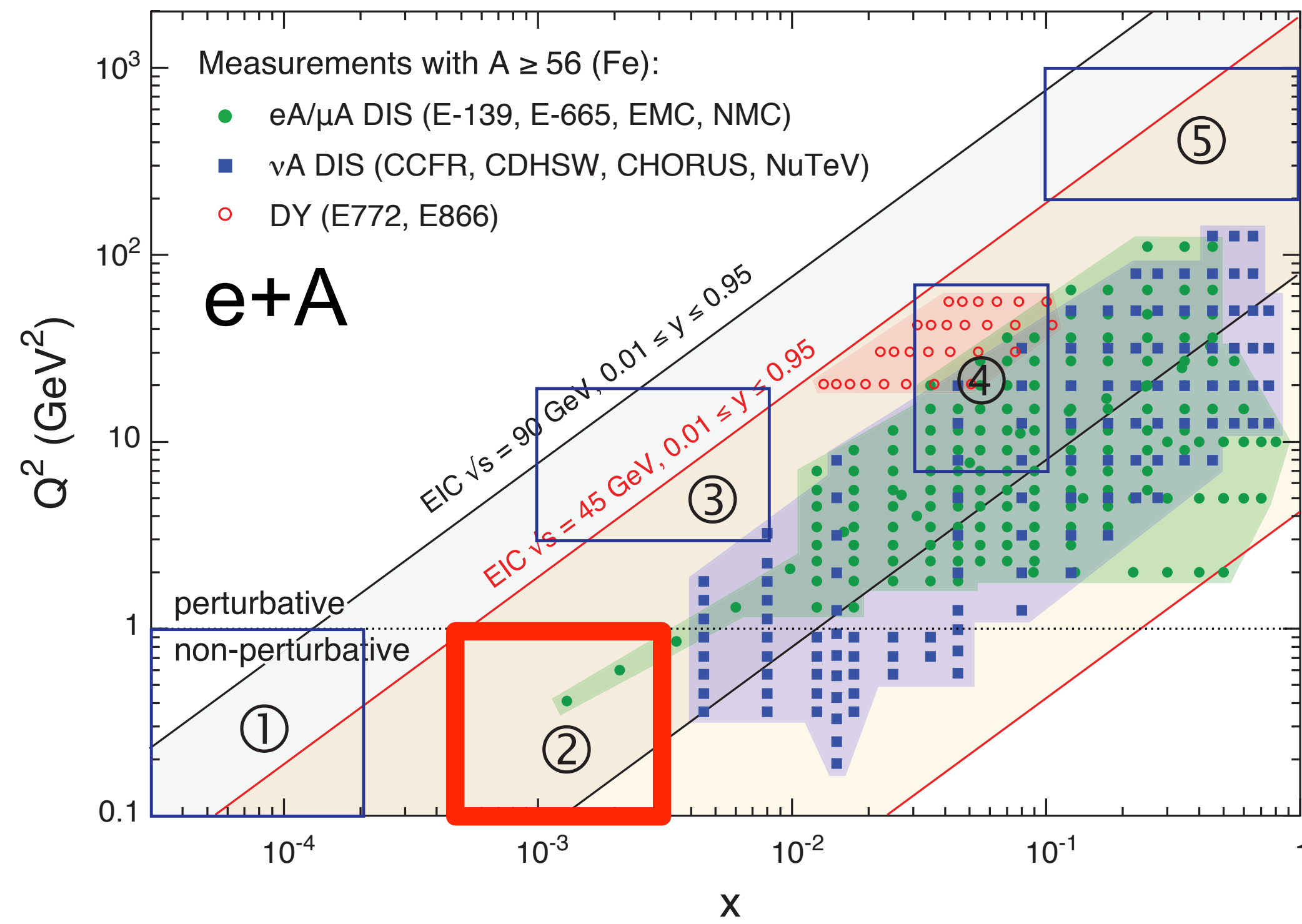

20 GeV on 100 GeV,  $0.1 < Q^2 < 1$  GeV<sup>2</sup>,  $5 \cdot 10^{-4} < x < 3 \cdot 10^{-3}$

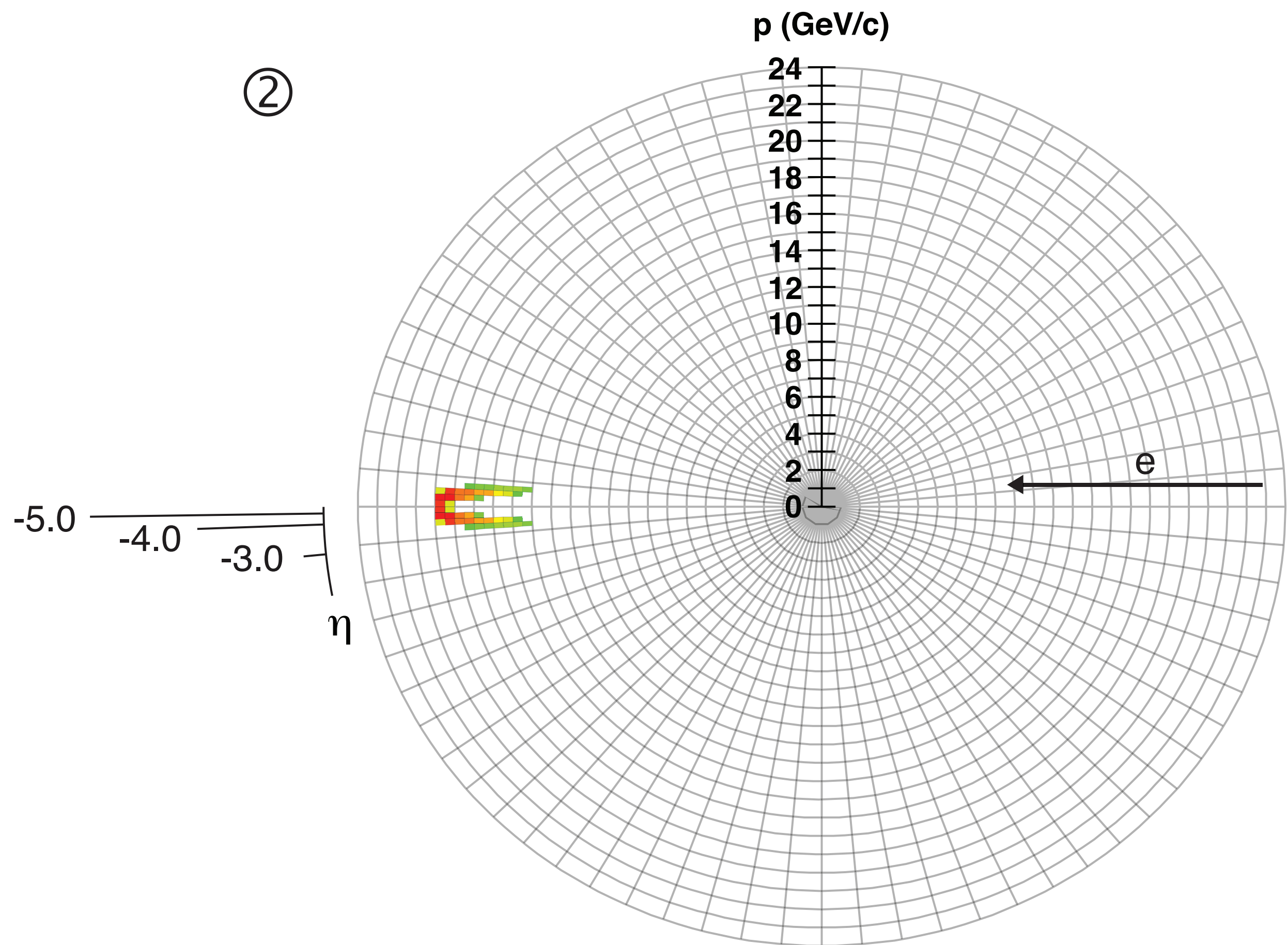

# Inclusive (All): Scattered Electron Requirements

The energy and angle of scatter electron gives key variables  $x, y, Q^2$

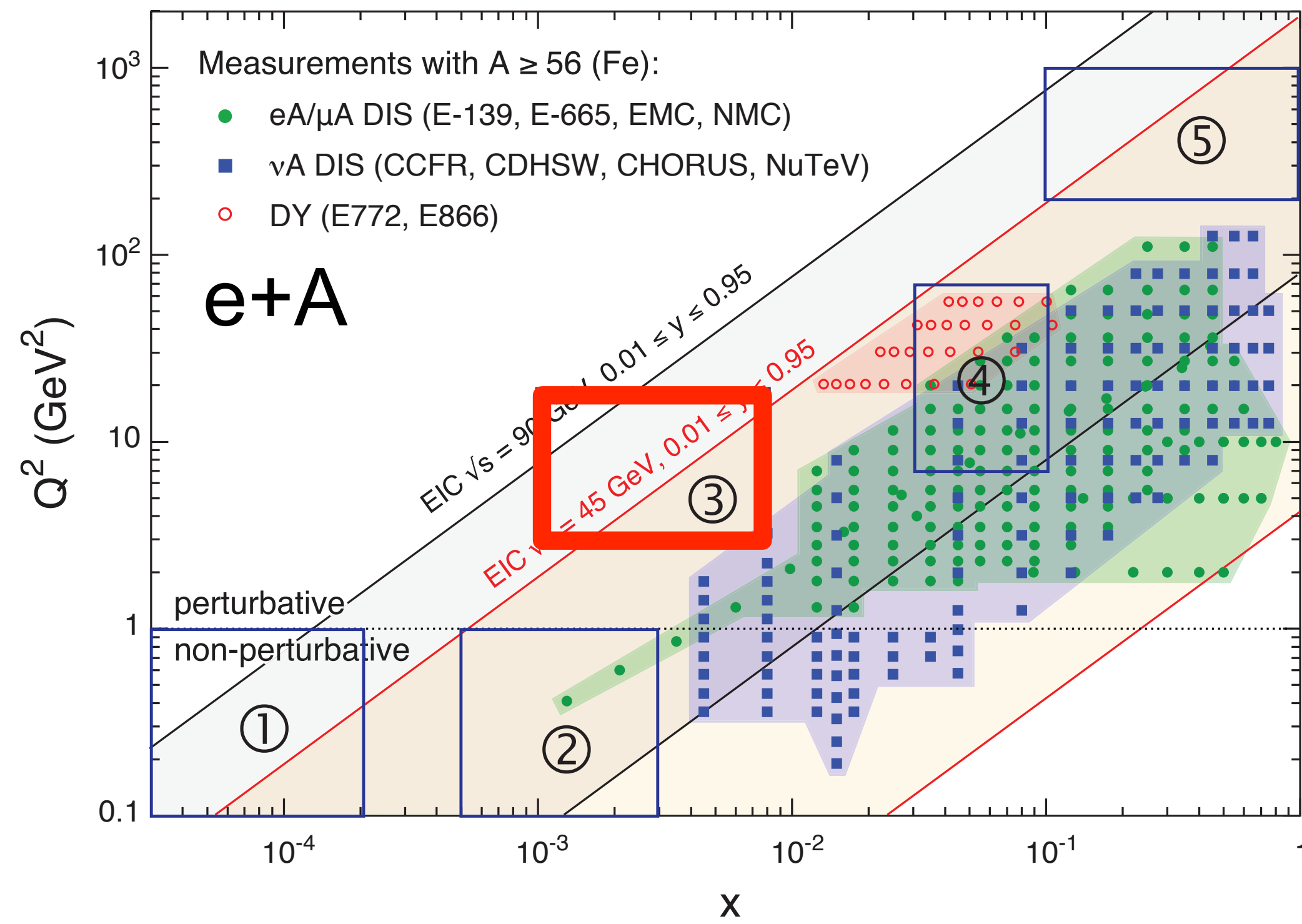

20 GeV on 100 GeV,  $3 < Q^2 < 20 \text{ GeV}^2$ ,  $1 \cdot 10^{-3} < x < 8 \cdot 10^{-3}$

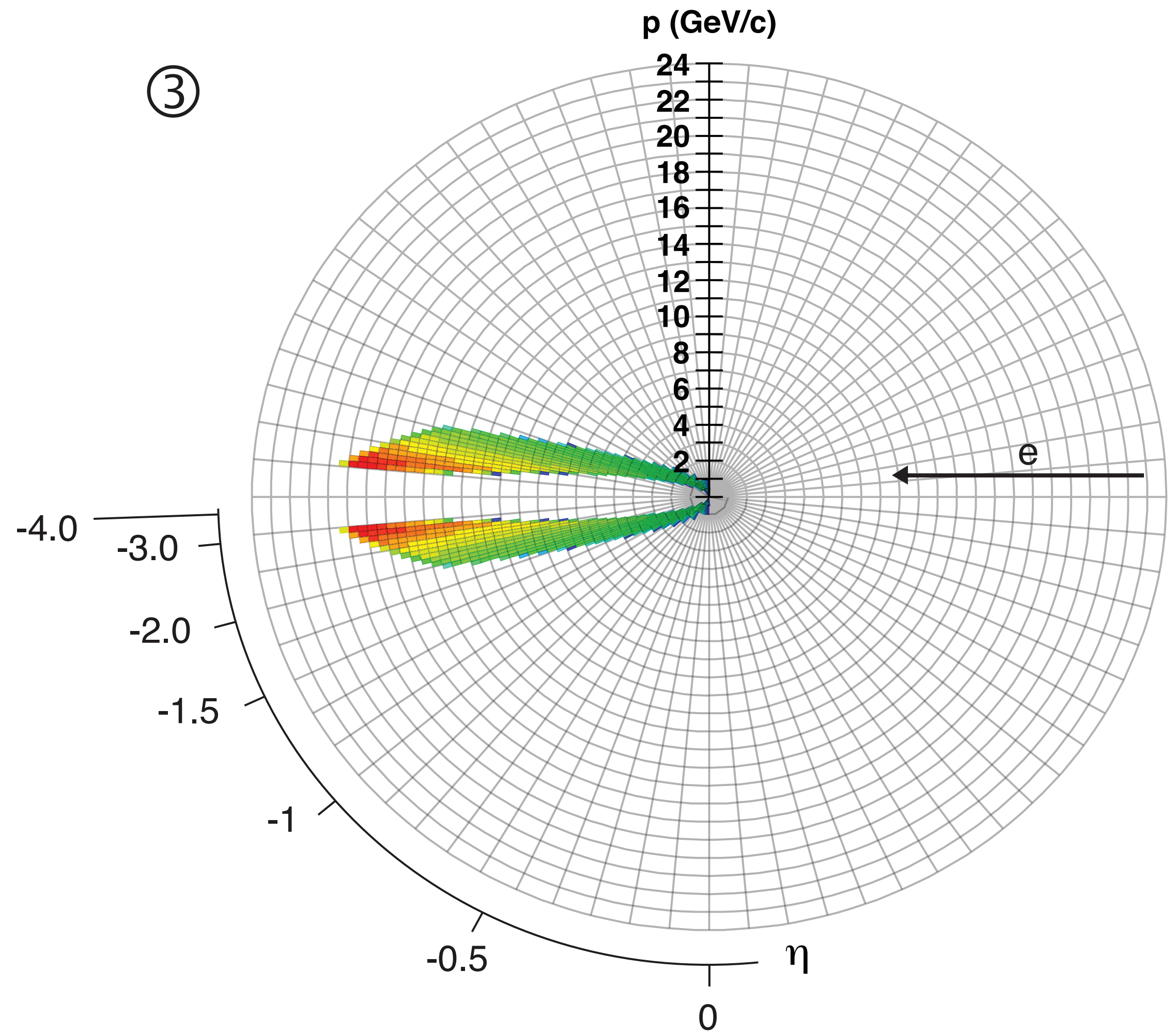

# Inclusive (All): Scattered Electron Requirements

The energy and angle of scatter electron gives key variables  $x, y, Q^2$

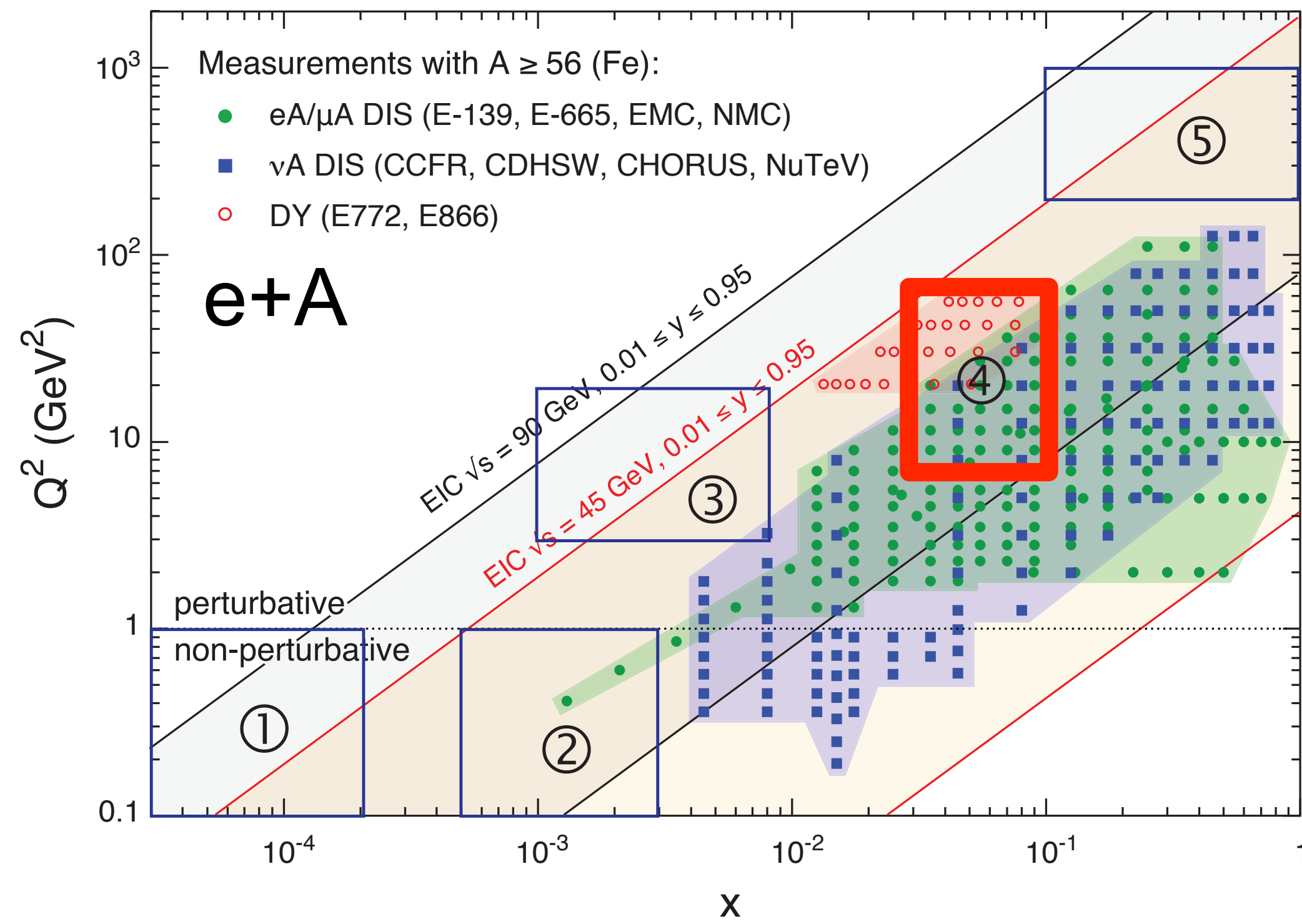

20 GeV on 100 GeV,  $7 < Q^2 < 70$  GeV<sup>2</sup>,  $3 \cdot 10^{-2} < x < 1 \cdot 10^{-1}$

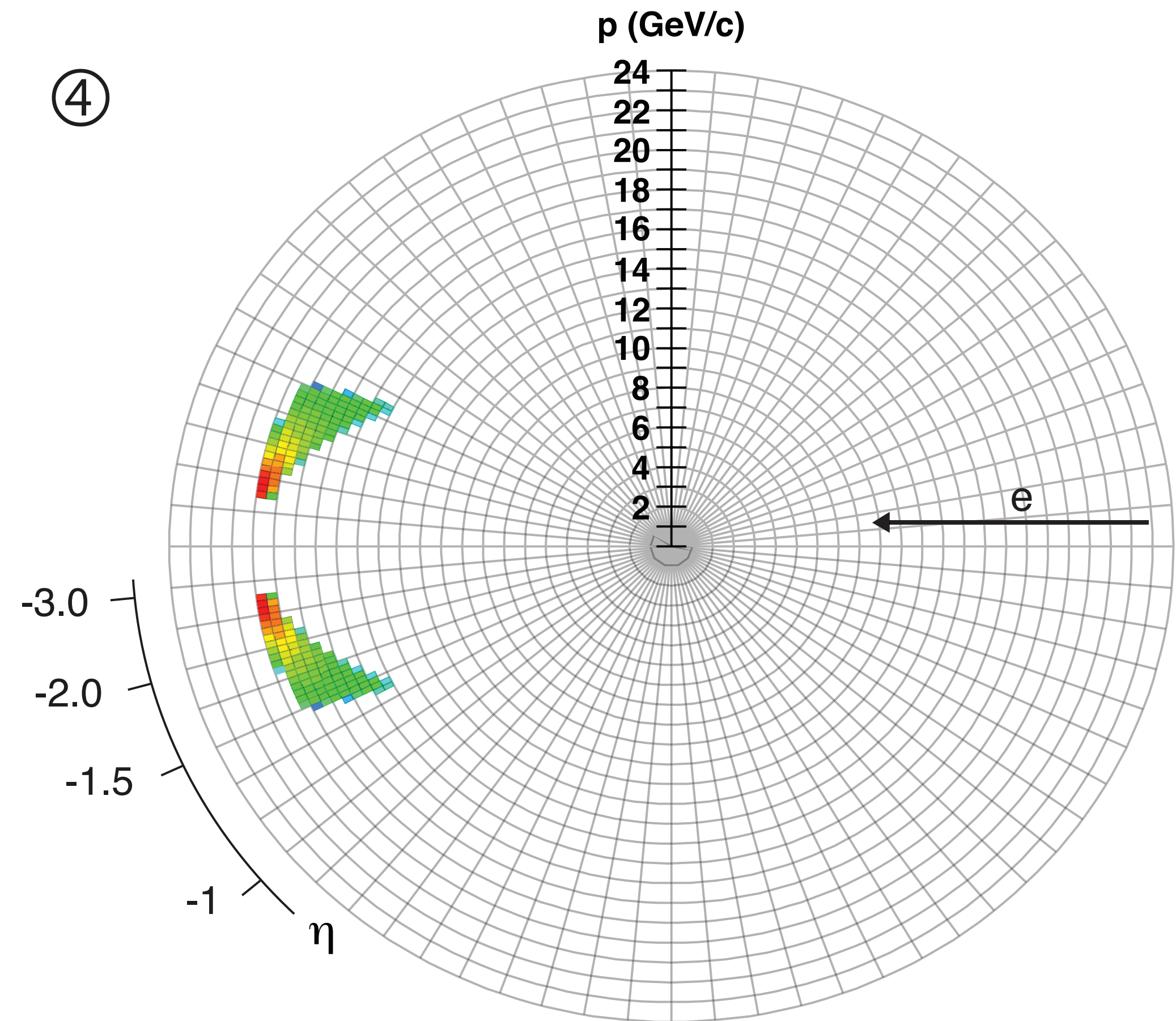

# Inclusive (All): Scattered Electron Requirements

The energy and angle of scatter electron gives key variables  $x, y, Q^2$

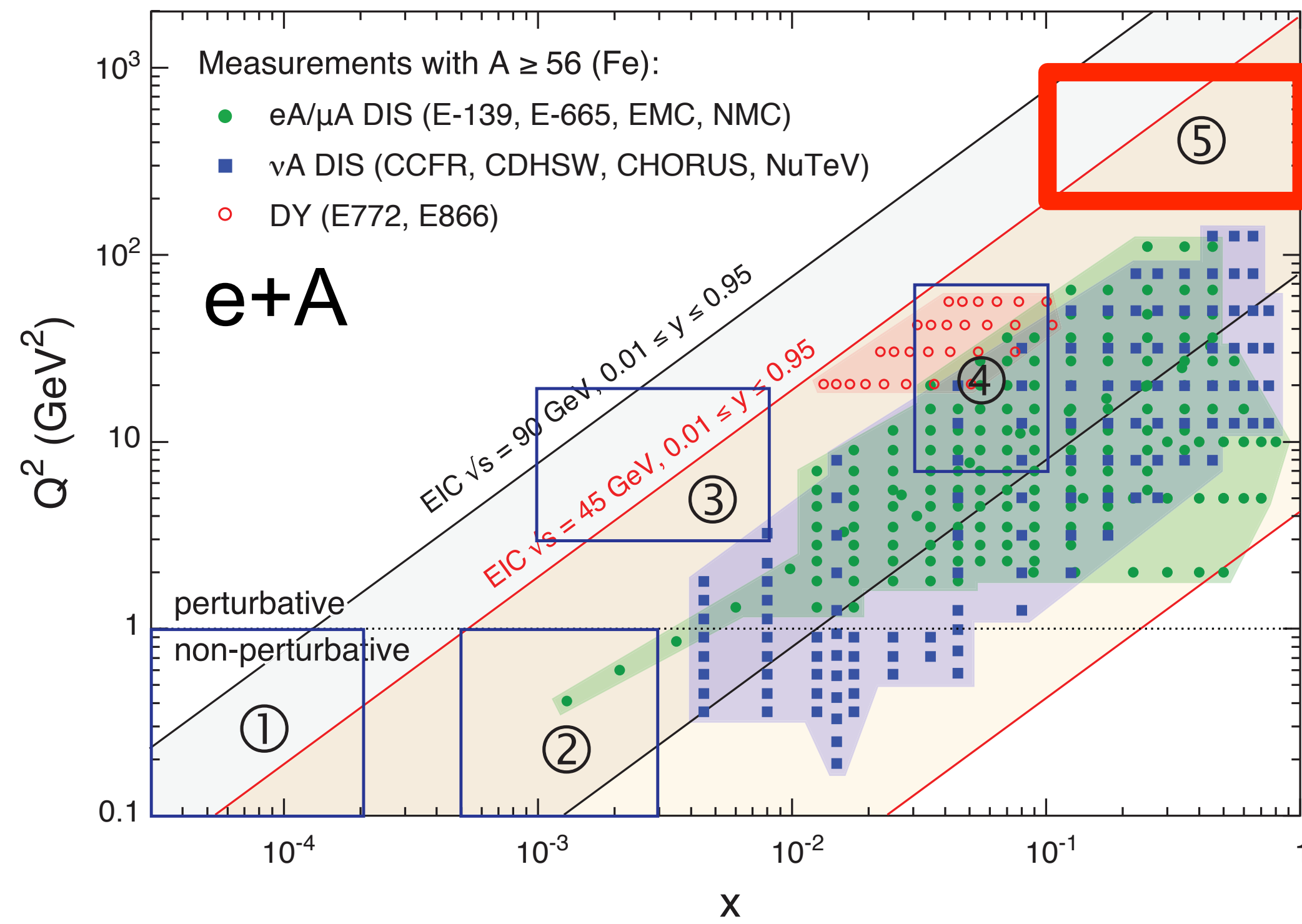

20 GeV on 100 GeV,  $200 < Q^2 < 1000$  GeV<sup>2</sup>,  $0.1 < x < 1$

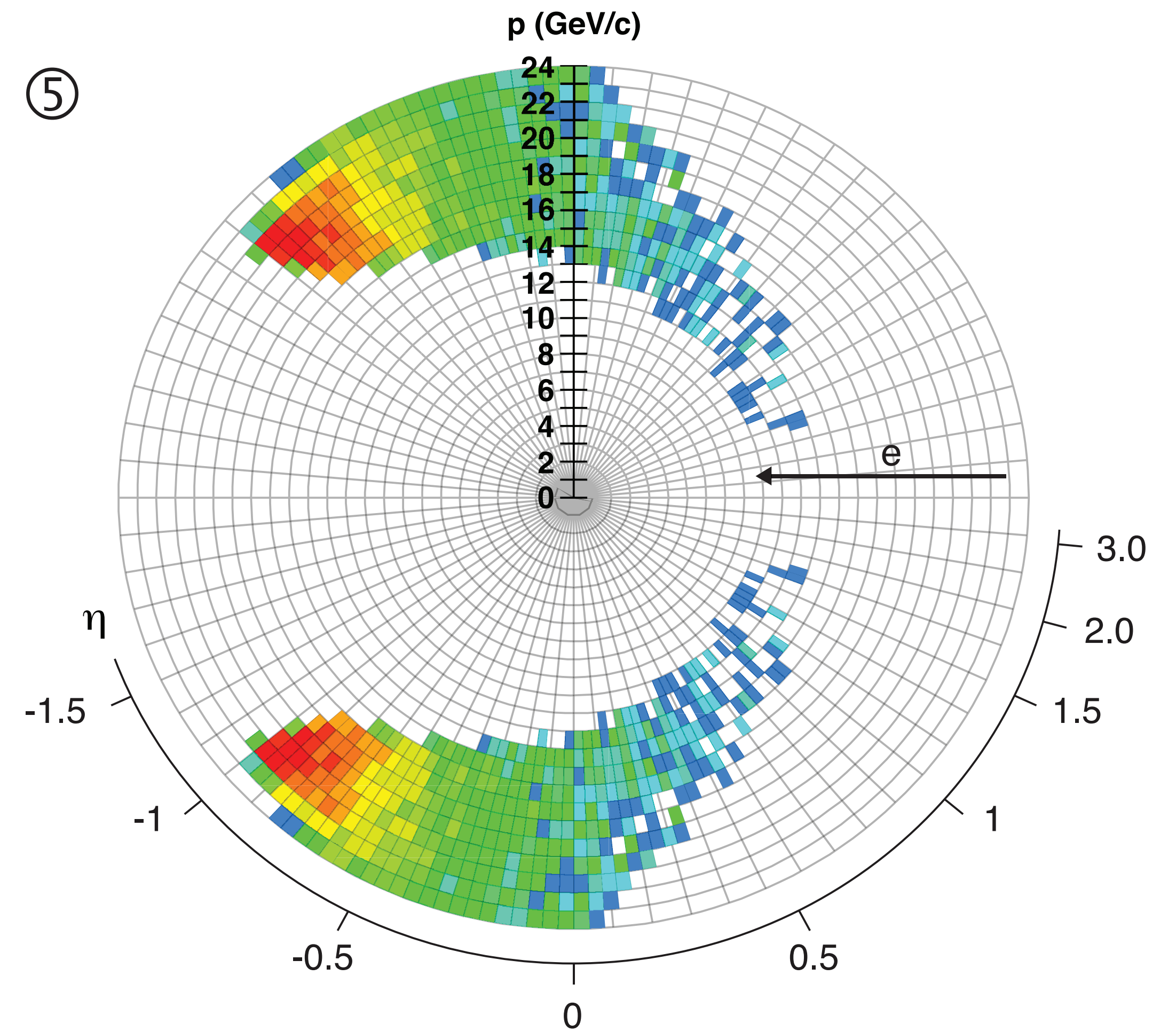

# Inclusive (All): Scattered Electron Requirements

The energy and angle of scatter electron gives key variables  $x, y, Q^2$

- $e'$  Measurement Requires:
  - ⦿ excellent electron identification ( $e/h$ )
  - ⦿ equal rapidity coverage for tracking and calorimeter
  - ⦿ low material budget to reduce bremsstrahlung
  - ⦿ momentum/energy and angular resolution are critical

20 GeV on 100 GeV,  $200 < Q^2 < 1000 \text{ GeV}^2$ ,  $0.1 < x < 1$

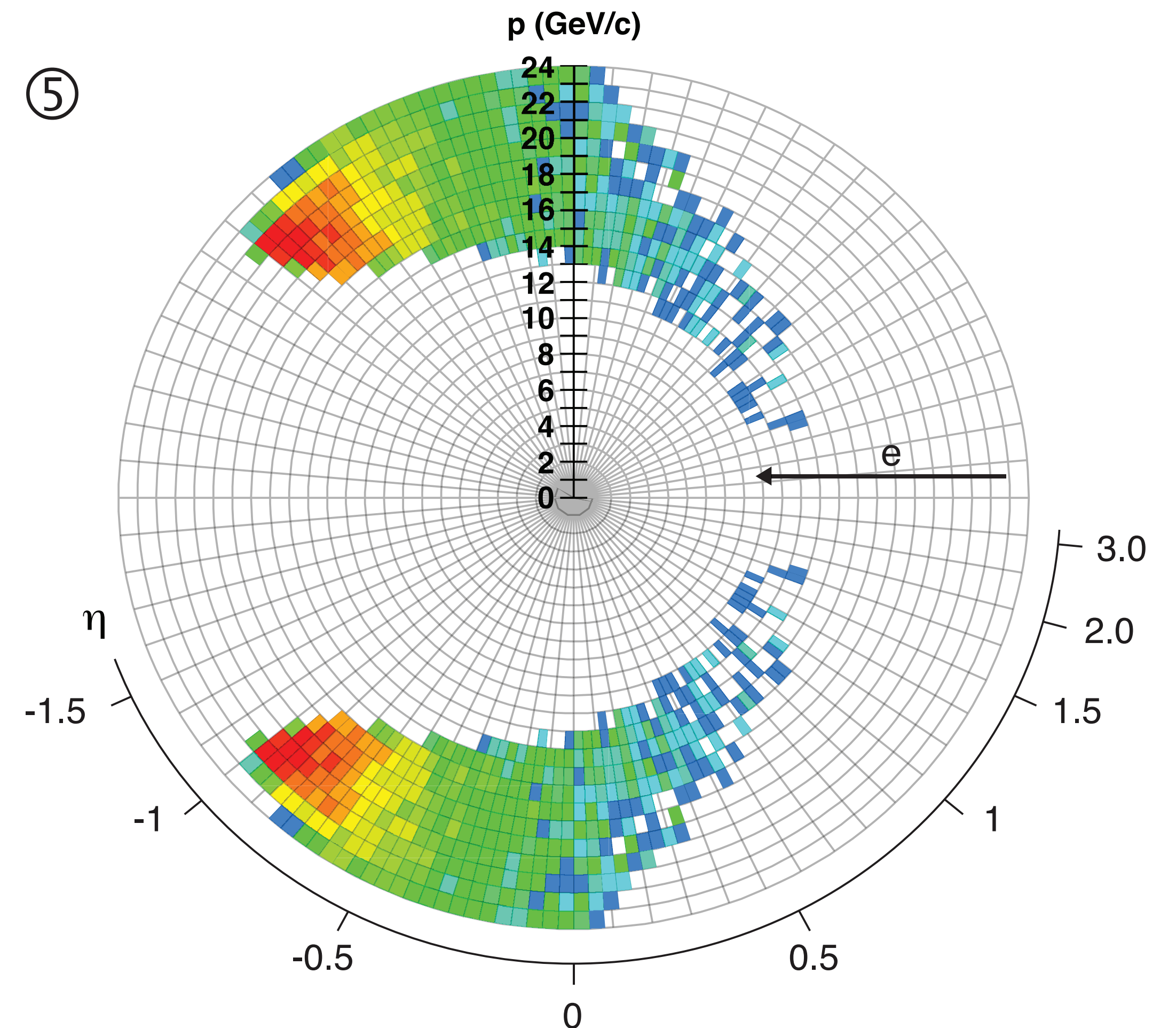

# SIDIS: Hadron Identification Requirements

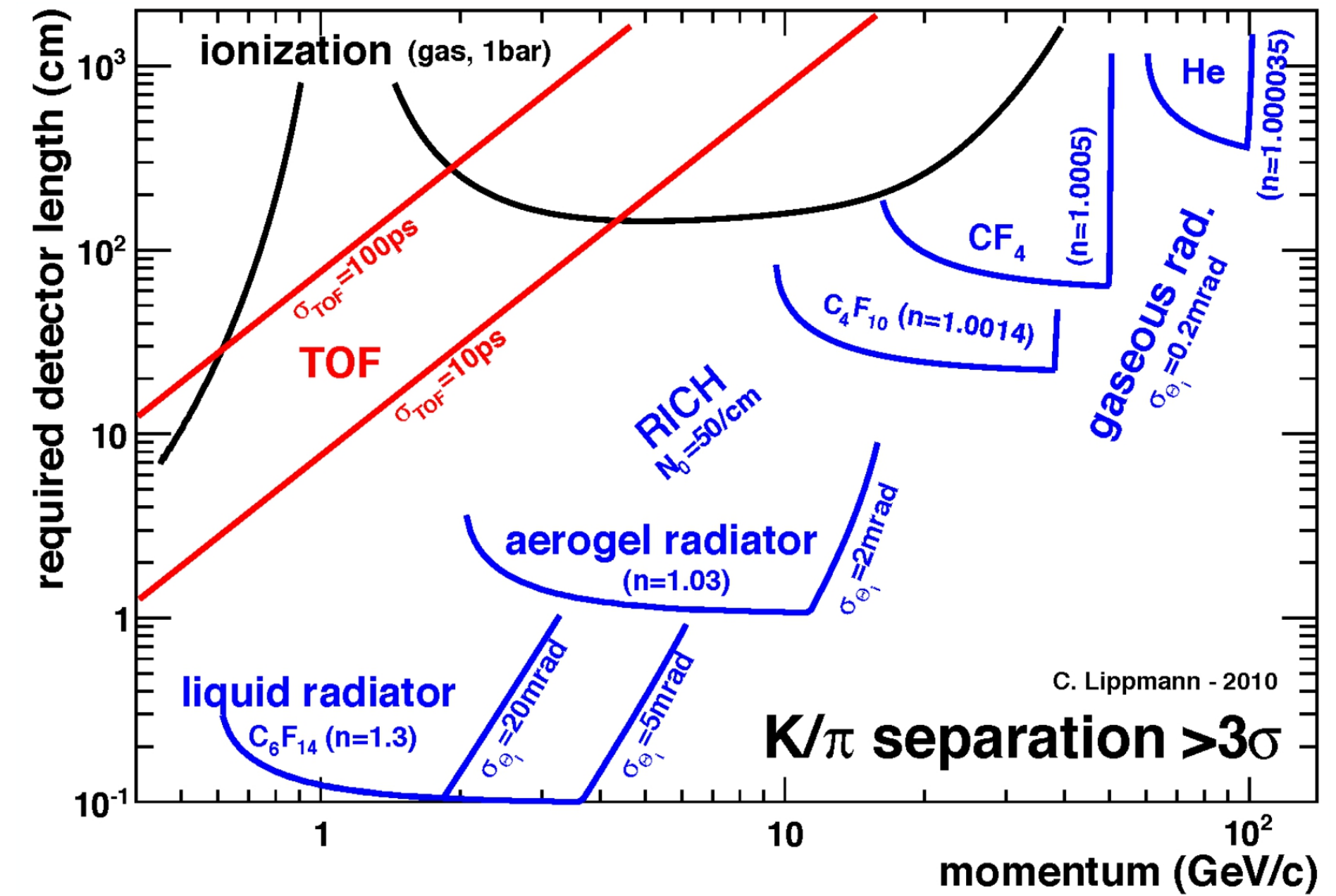
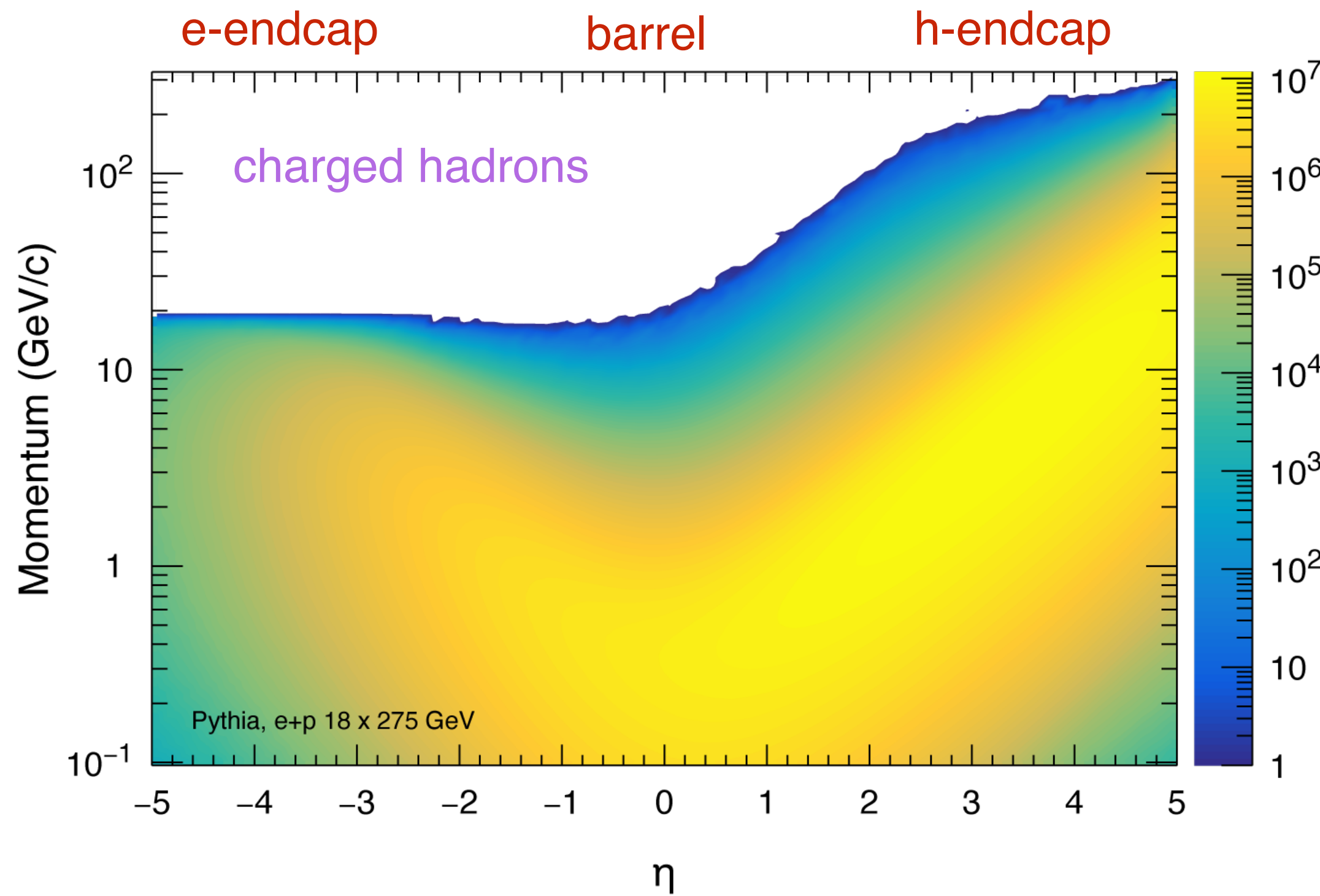

- Physics Requirements

- $\pi^\pm, K^\pm, p^\pm$  separation over a wide range  $|\eta| \leq 3.5$

- Strong Momentum– $\eta$  correlation

- $-5 < \eta < 2$ :  $0.2 < p < 10$  GeV/c
- $2 < \eta < 5$ :  $0.2 < p < 50$  GeV/c

- Need absolute particle numbers at high purity and low contamination
- Require more than one technology to cover the entire range
- EIC PID needs are more demanding than at most collider detector

# EIC General Purpose Detector Concept

## Magnet

- Cannot affect the  $e$  beam to avoid synchrotron radiation  $\Rightarrow$  Solenoidal Field (common in HEP)
- Downside is missing bending power  $\int \mathbf{B} \cdot d\mathbf{l}$  in forward and backward region putting extreme requirements on tracking (h) and calorimetry (e)

very low  $Q^2$  scattered lepton  
Bethe-Heitler photons for luminosity

Luminosity Detector

Low  $Q^2$ -Tagger  
Off-momentum tracker

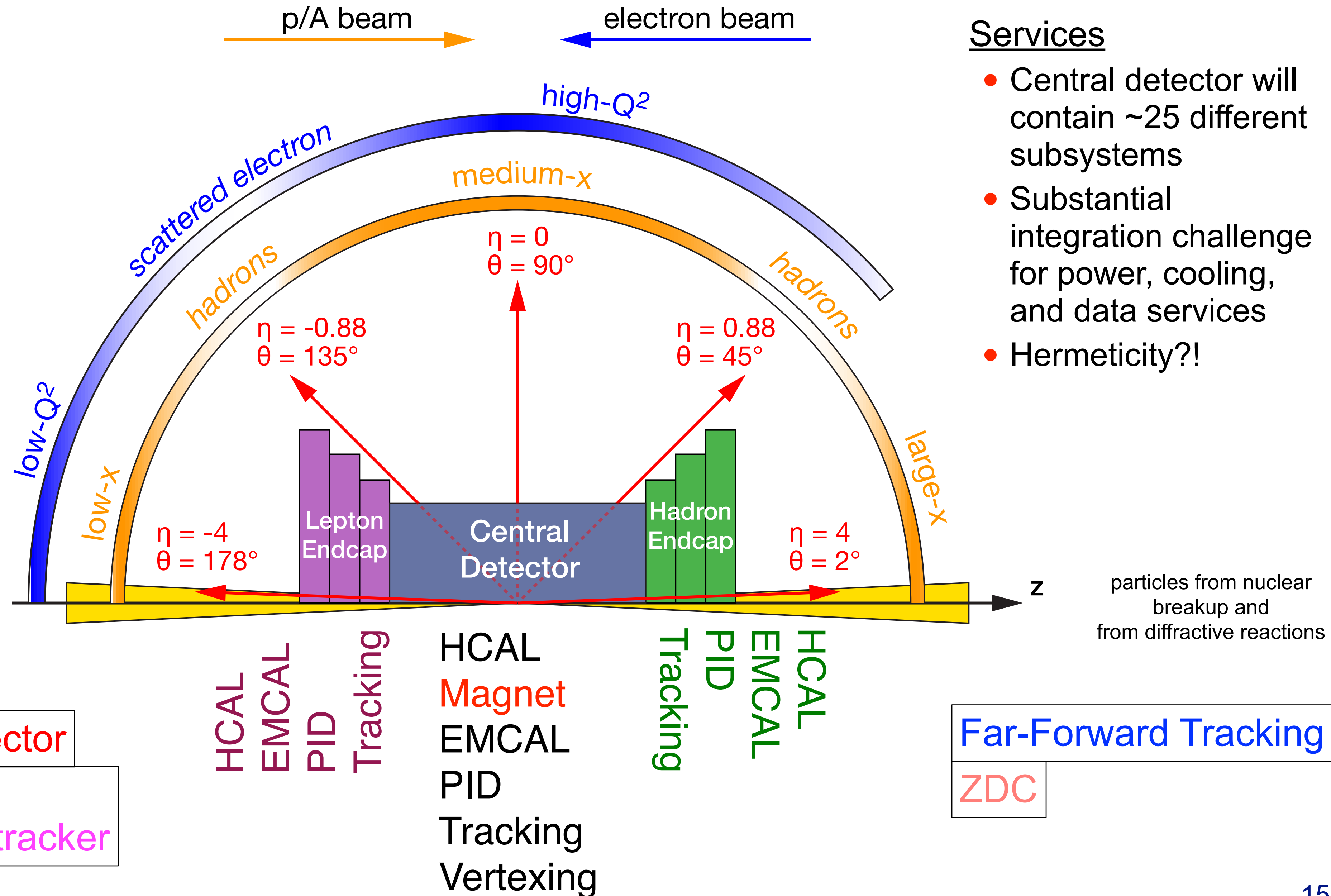

## Services

- Central detector will contain  $\sim 25$  different subsystems
- Substantial integration challenge for power, cooling, and data services
- Hermeticity?!

# Brief Review of Requirements (see Yellow Report)

- Hermetic detector, low mass inner tracking
- Moderate radiation hardness requirements
- Electron measurement & jets in approx.  $-4 < \eta < +4$
- Good momentum resolution
  - ▶ central:  $\sigma(p)/p = 0.05 \% p \oplus 0.5 \%$
  - ▶ fwd/bkd:  $\sigma(p)/p = 0.1 \% \oplus 0.5 \%$
- Good impact parameter resolution:
  - ▶  $\sigma = 5 \oplus 15/p \sin^{3/2} \theta$  ( $\mu\text{m}$ )
- Excellent EM resolution
  - ▶ central:  $\sigma(E)/E = 10 \% / \sqrt{E}$
  - ▶ backward:  $\sigma(E)/E < 2 \% / \sqrt{E}$
- Good hadronic energy resolution
  - ▶ forward:  $\sigma(E)/E \approx 50 \% / \sqrt{E}$
- Excellent PID  $\pi/K/p$ 
  - ▶ forward: up to 50 GeV/c
  - ▶ central: up to 8 GeV/c
  - ▶ backward: up to 7 GeV/c
- Low pile-up, low multiplicity, data rate  $\sim 500\text{kHz}$  (full lumi)

Hermeticity, low mass, and PID requirements make EIC detector design challenging

# electron Proton and Ion Collider experiment ePIC

- ePIC was founded in July 2022
- ePIC is a community of scientists dedicated to realizing the EIC science mission
- They work closely with the EIC Project formed by the two host labs, BNL and JLab
- ePIC is international:
  - ▶ 893 Members
  - ▶ 177 Institutions
  - ▶ 29 Countries

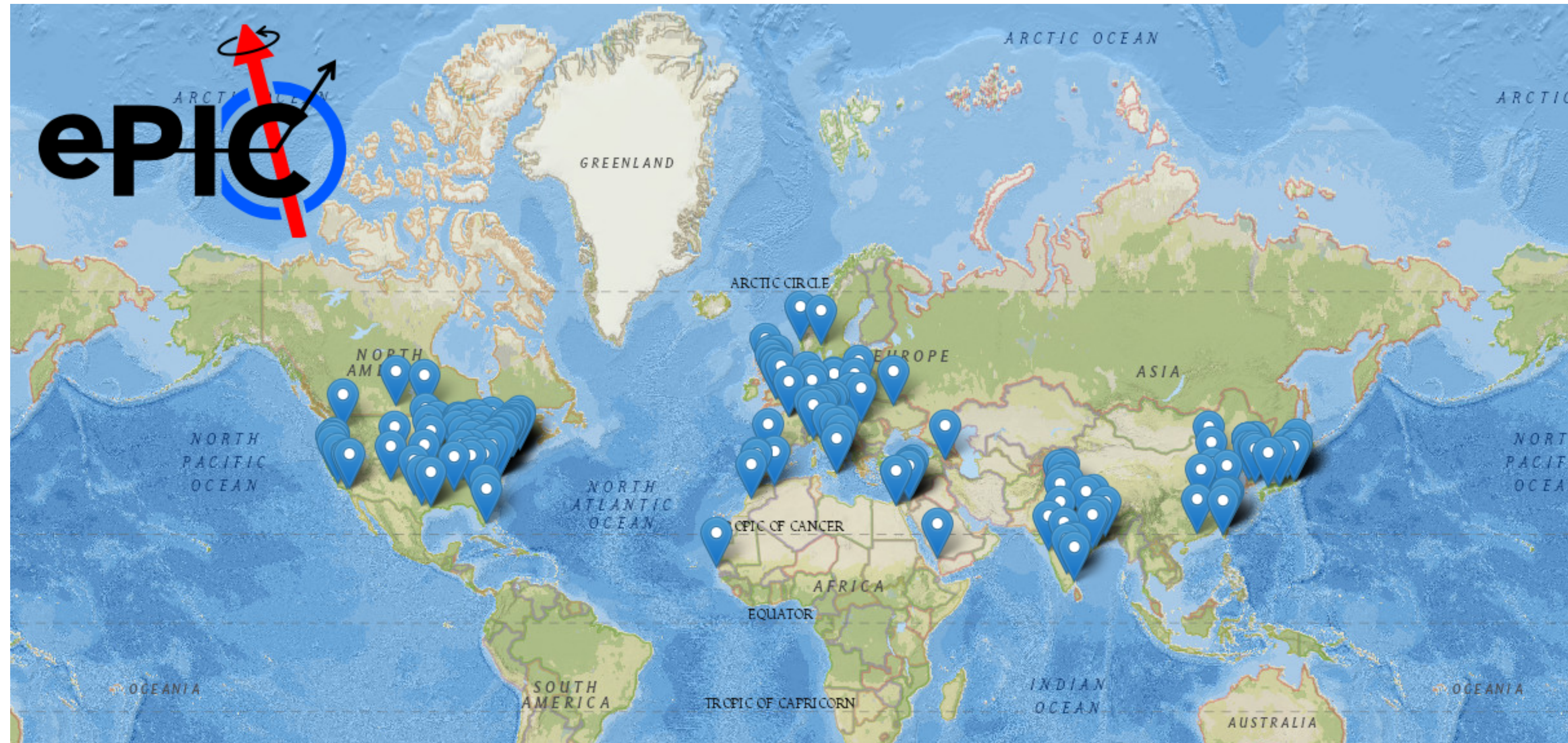

JLab, Jan. 2023



Warsaw, July 2023



ANL, January 2024



Lehigh, July 2024

# ePIC Overview

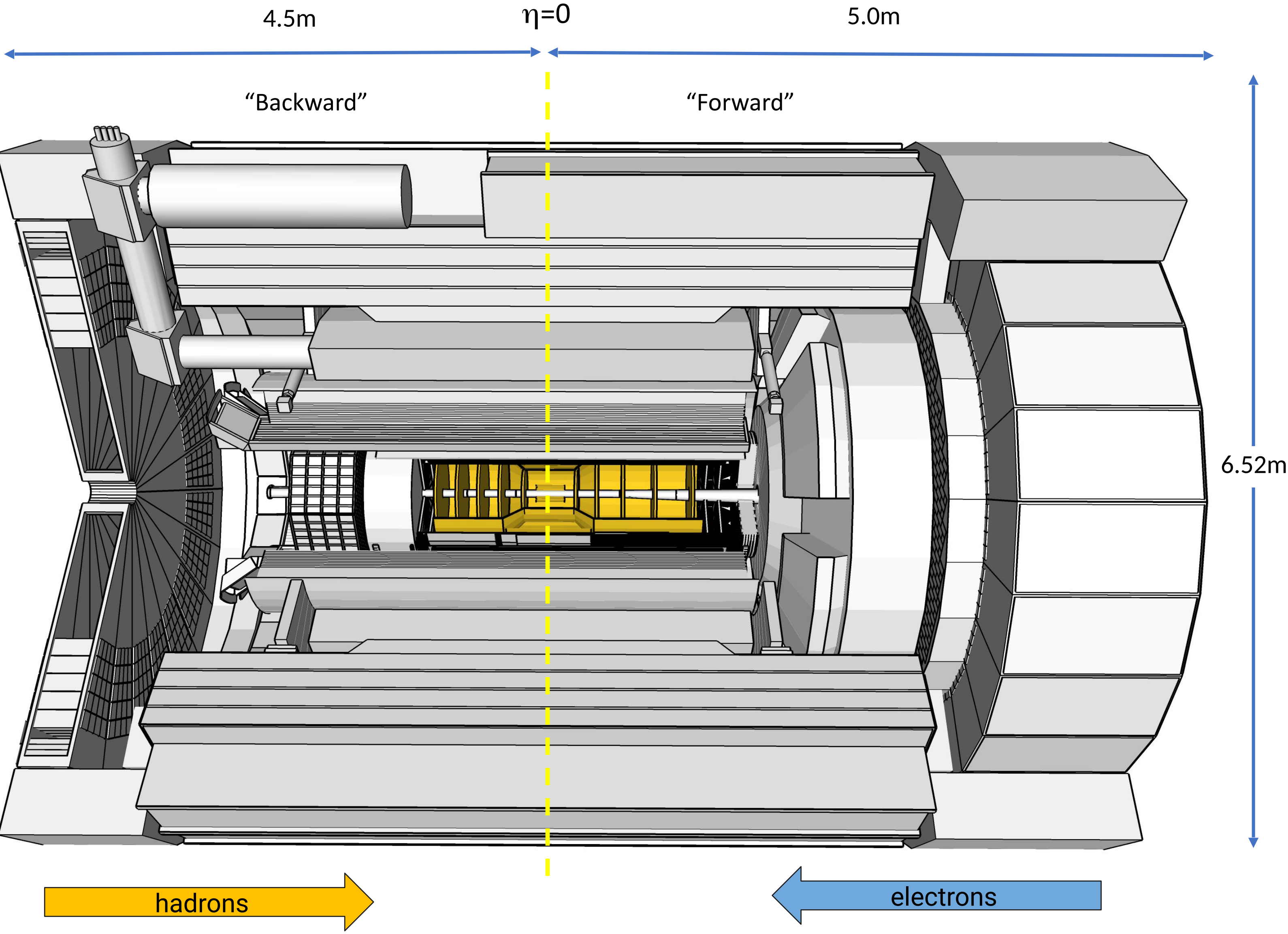
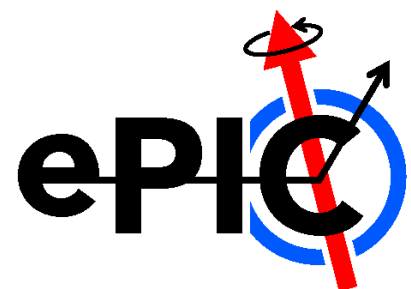

### Tracking:

- New 1.7T (2.0T) solenoid
- Si MAPS Tracker
- MPGDs ( $\mu$ RWELL/ $\mu$ Megas)

# ePIC Overview

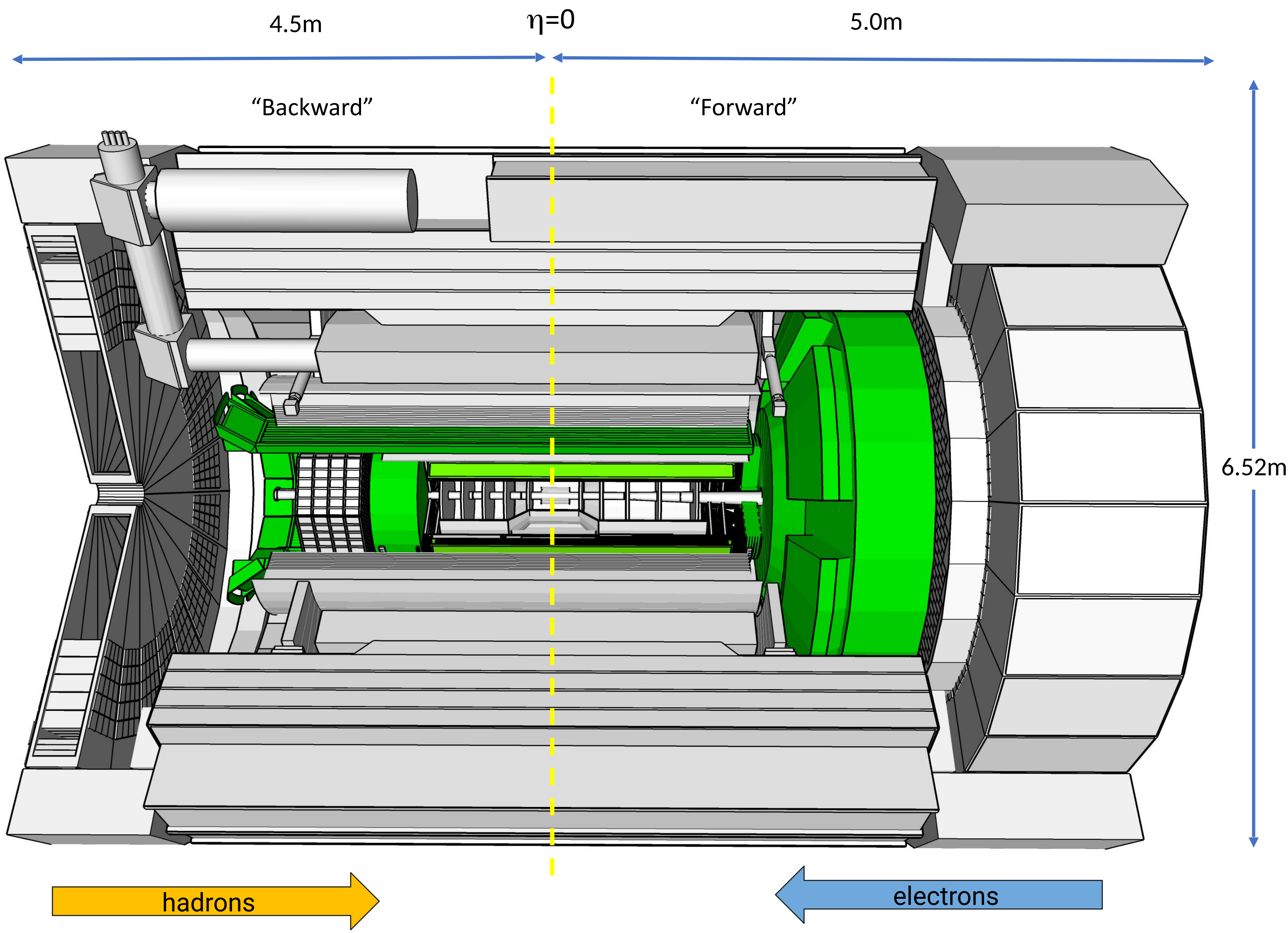
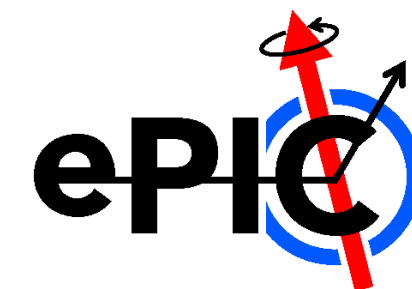

### Tracking:

- New 1.7T (2.0T) solenoid
- Si MAPS Tracker
- MPGDs ( $\mu$ RWELL/ $\mu$ Megas)

### PID:

- high-performance DIRC
- proximity-focused RICH
- dual-radiator RICH
- AC-LGAD ( $\sim 30$ ps TOF)

# ePIC Overview

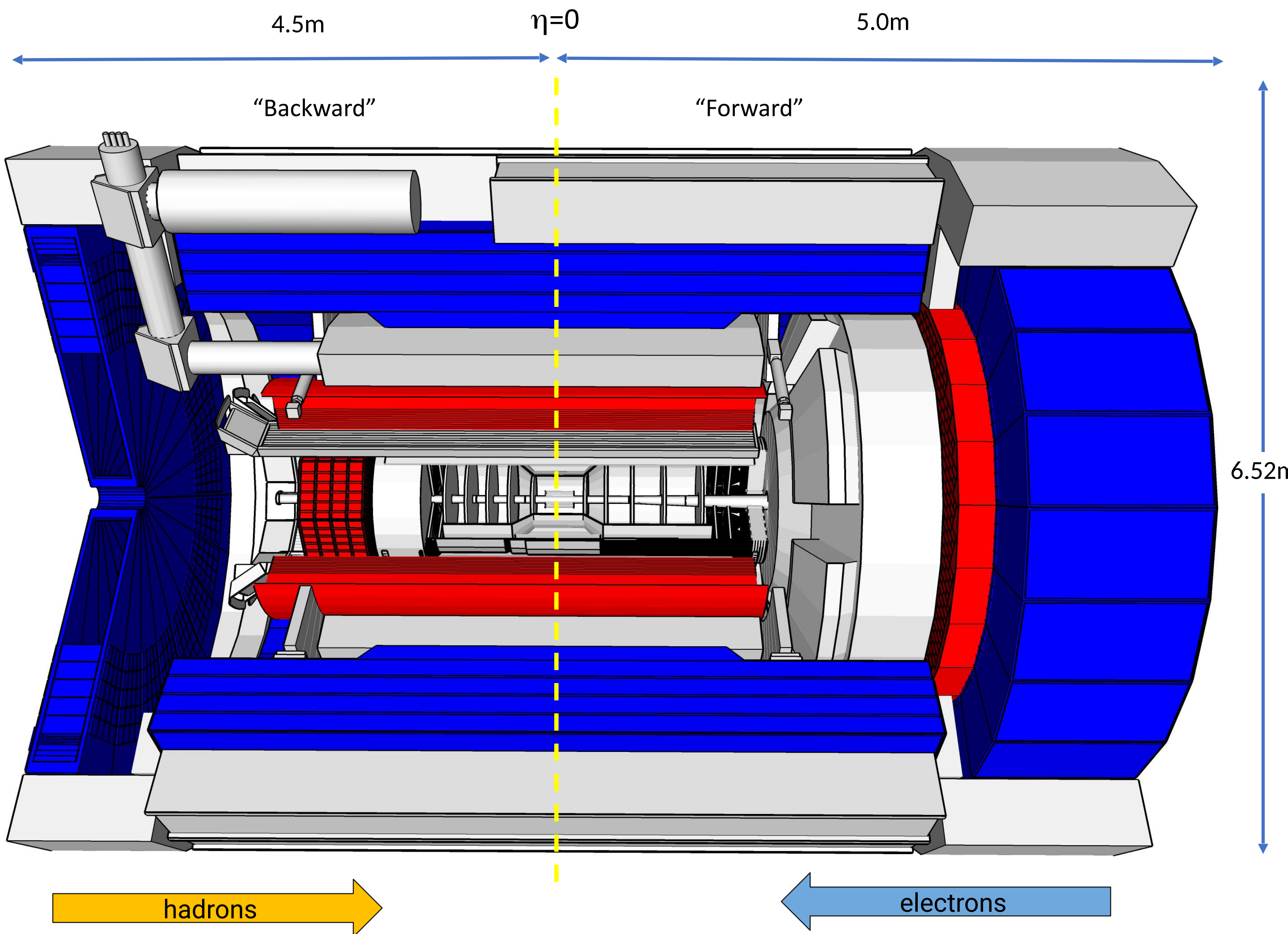
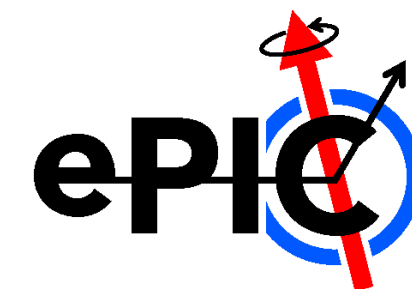

## Tracking:

- New 1.7T (2.0T) solenoid
- Si MAPS Tracker
- MPGDs ( $\mu$ RWELL/ $\mu$ Megas)

## PID:

- high-performance DIRC
- proximity-focused RICH
- dual-radiator RICH
- AC-LGAD ( $\sim 30$ ps TOF)

## Calorimetry:

- Imaging Barrel EMCal
- PbWO4 EMCal (backwards)
- Finely segmented EMCal +HCal in forward direction
- Outer HCal (sPHENIX re-use)
- Backwards HCal (tail-catcher)

# MARCO Magnet

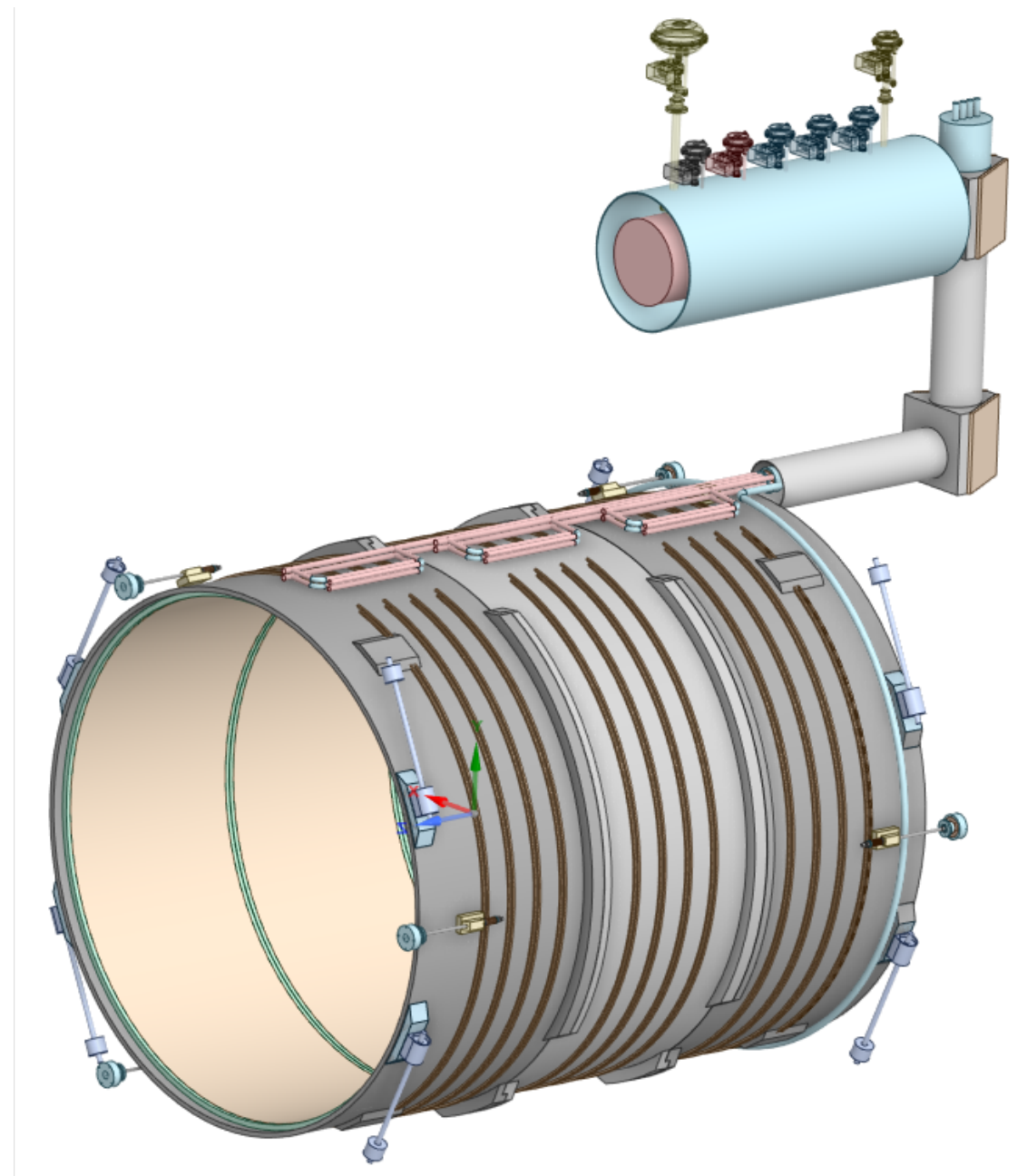
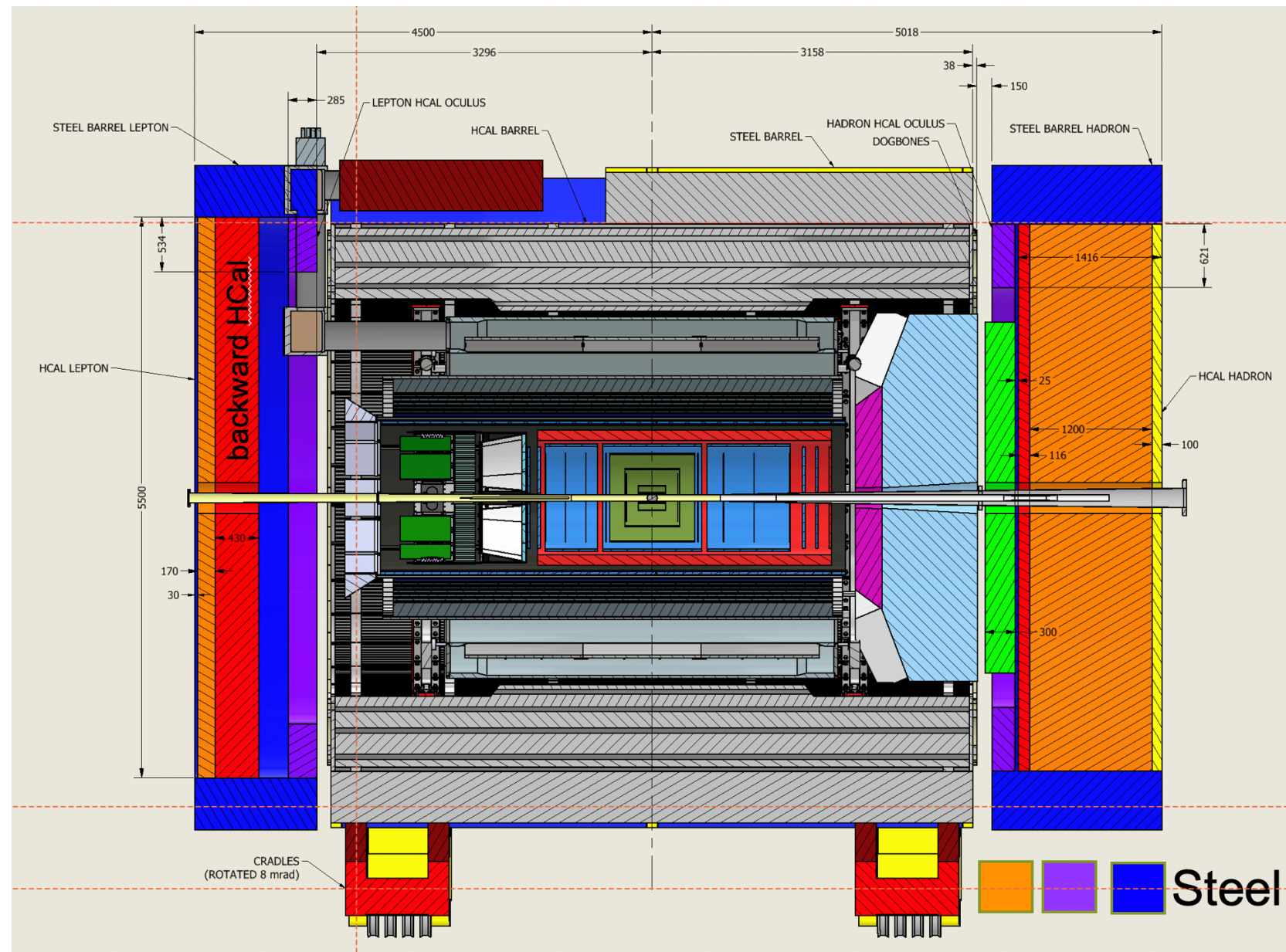

- New solenoidal SC magnet
- Coil is divided in 3 modules with 6 layers each. This is done mainly to accommodate possible conductor length.
- Flux return steel layout fully defined to minimize forces and fringe fields ( $\sim 10\text{G}$ )

## Robust and safe operating parameters

$B_0$	1.5 T	1.7 T	2.0 T	Units
Current	2942	3335	3924	A
$T_{op}$	4.7	4.7	4.7	K
$B_{peak}$	2.00	2.27	2.67	T
Temp. margin	3.06	2.82	2.45	K
Load line margin	59.6	54.2	46.1	%
$I / I_c(T, B_{peak})$	17.9	22.1	29.3	%

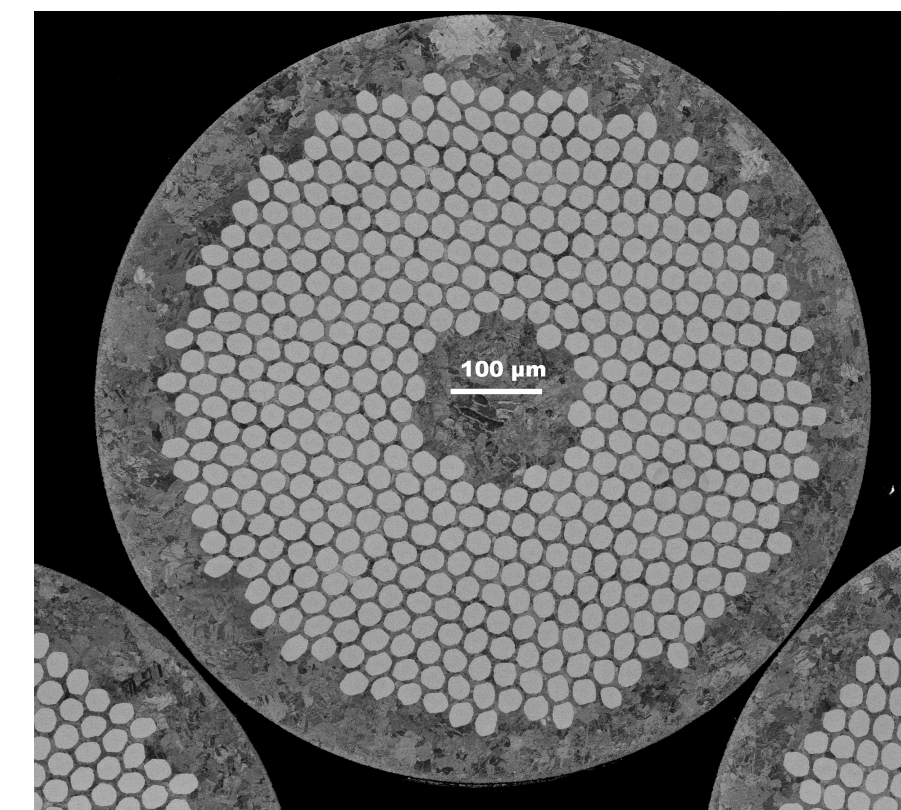

Magnet – strands for sample tests, the filaments are beautifully arranged – These are the final quality assurance tests before starting the long-lead procurement for conductor

# Barrel Tracking

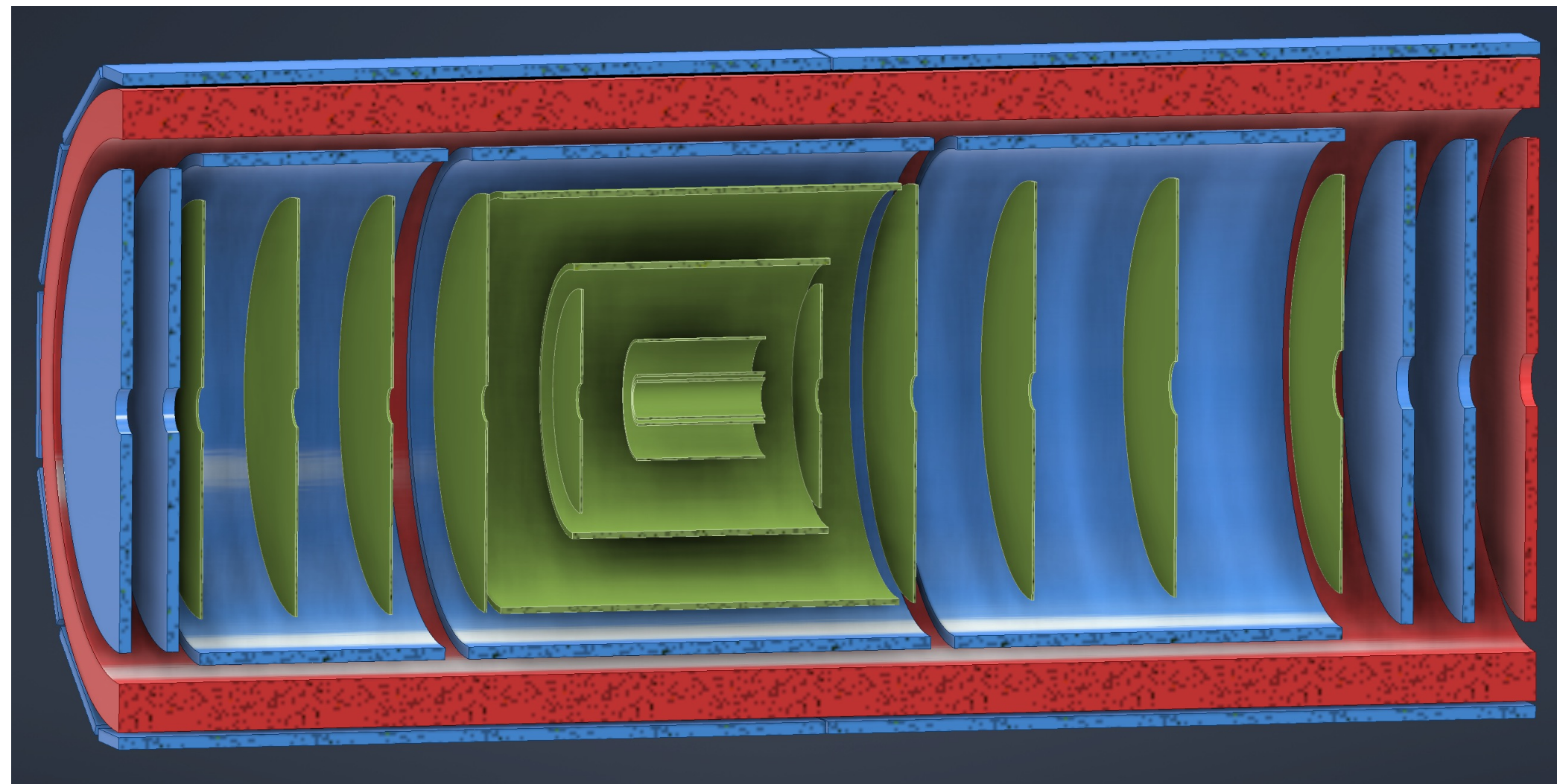

SVT

MPGDs

ToF (fiducial volume)

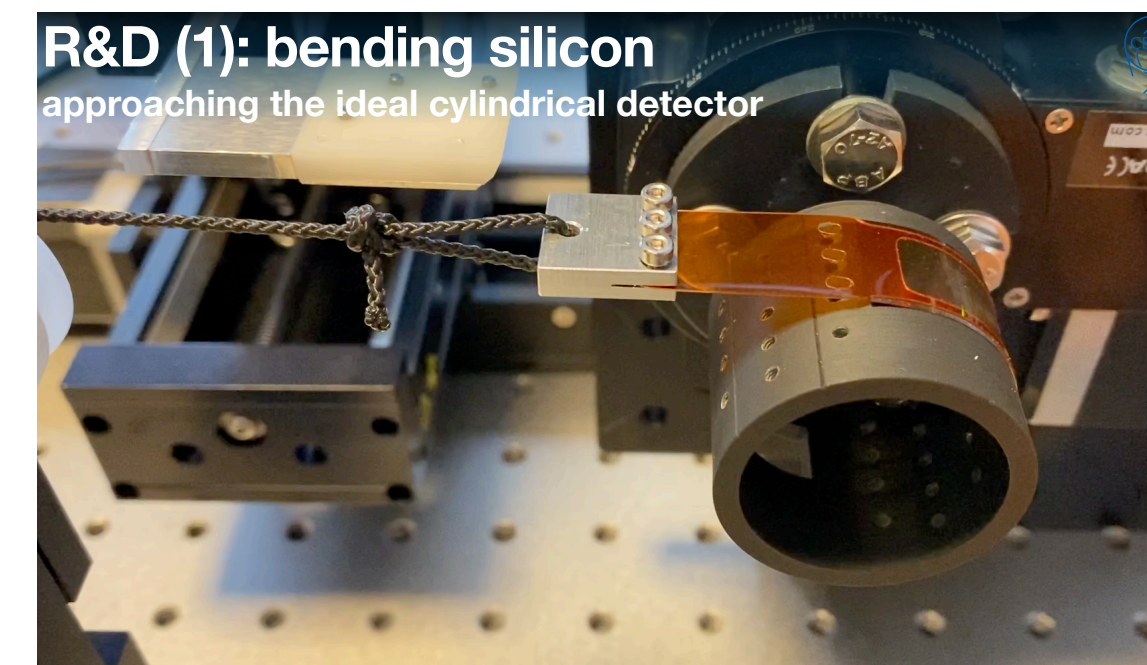
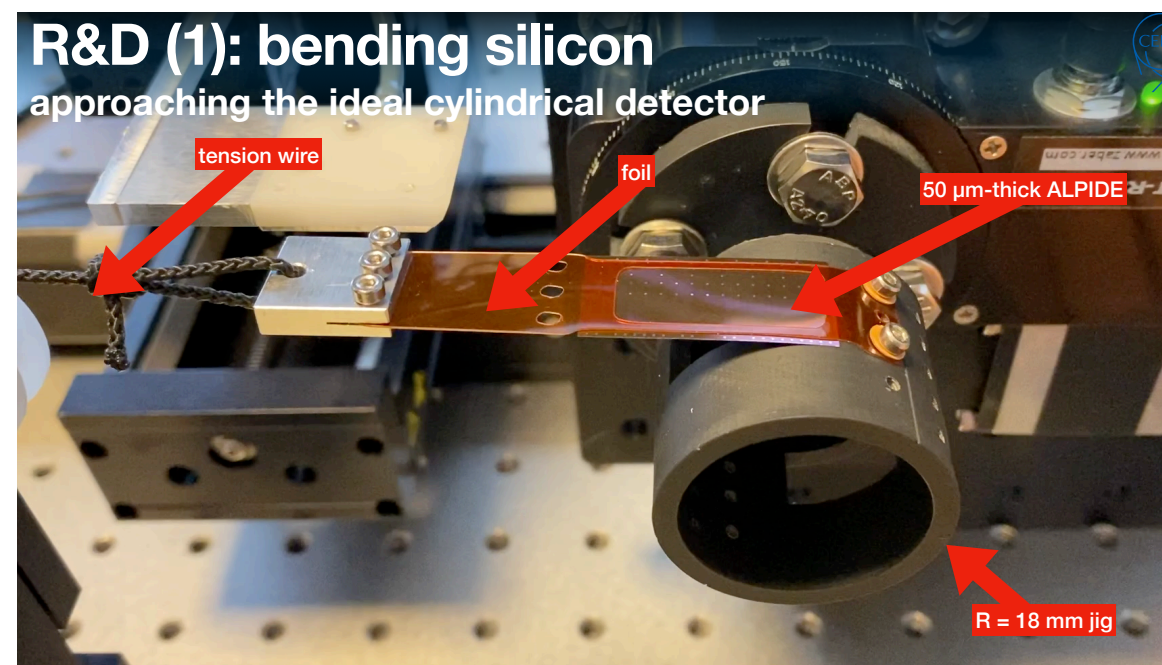

Bending 20  $\mu\text{m}$  silicon



## Si Vertex/Inner Barrel (3 layers)

- ITS3/sensor: Joint effort with ALICE/CERN (SVT Consortium)
- Large-area, wafer-scale, stitched sensors bent around beam pipe using latest 65 nm MAPS technology
- Small pixels (20  $\mu\text{m}$ ), low power consumption (<20 mW/cm<sup>2</sup>) and material budget ( $\sim 0.05\%$   $X/X_0$ ) per layer
- Vertex layers optimized for beam pipe bake-out and ITS-3 sensor size

# Barrel Tracking

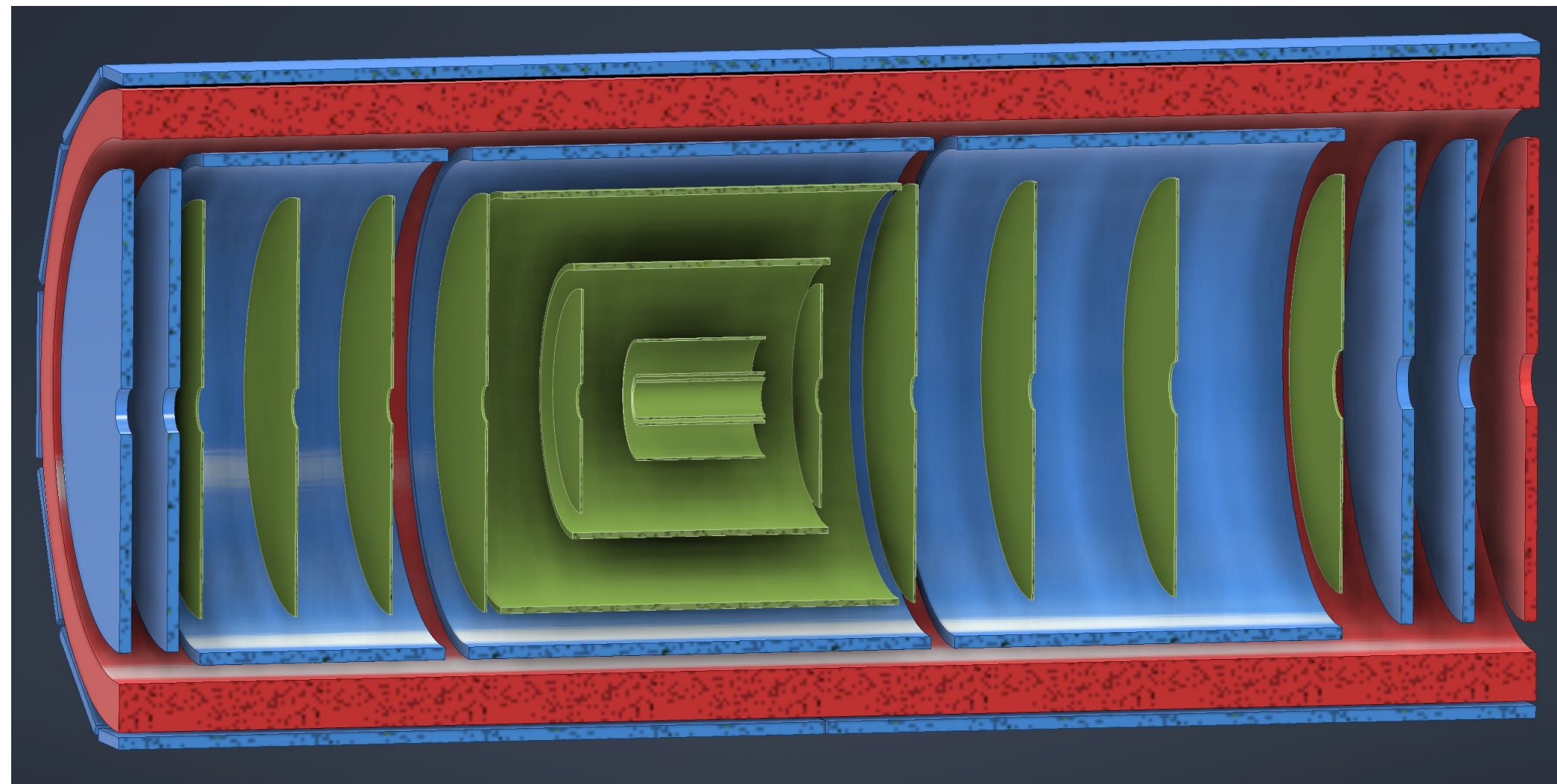

SVT

MPGDs

ToF (fiducial volume)

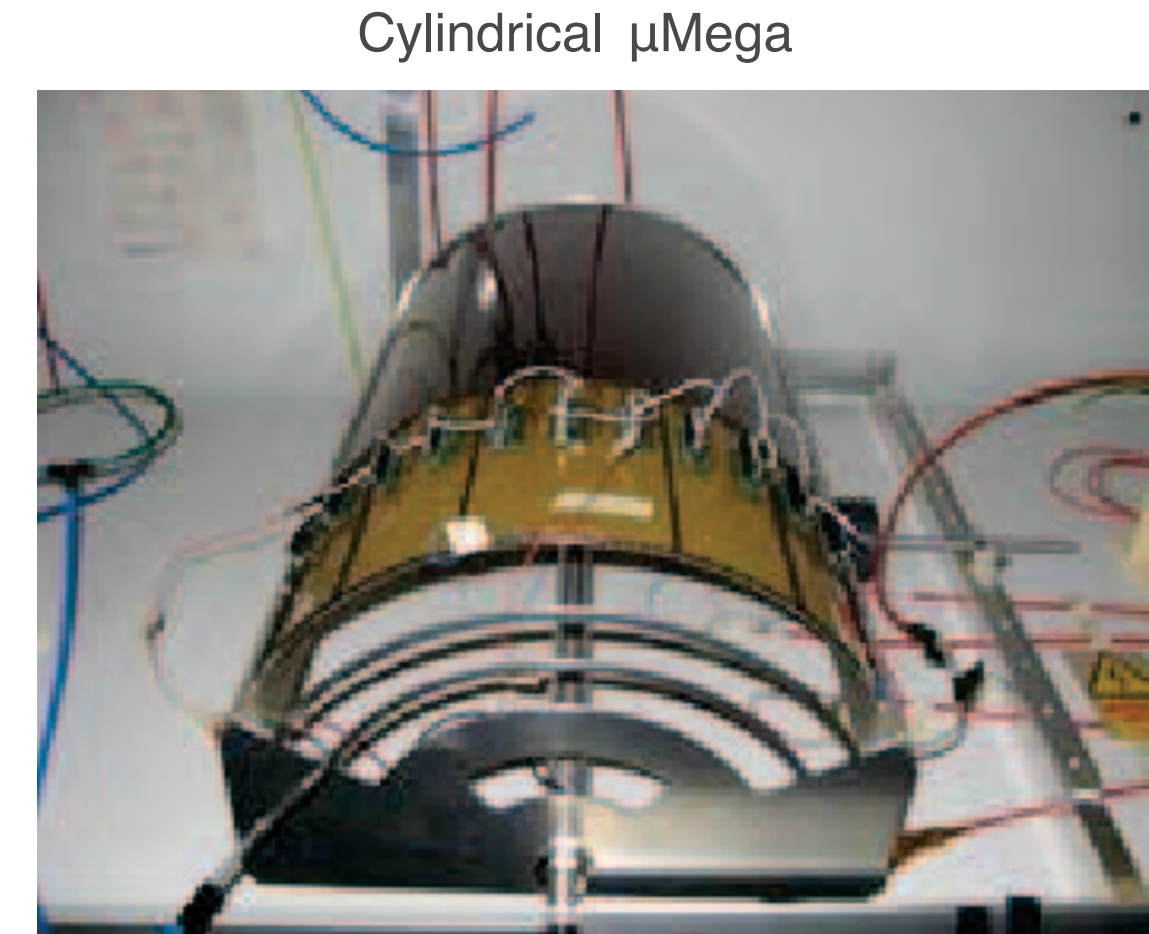
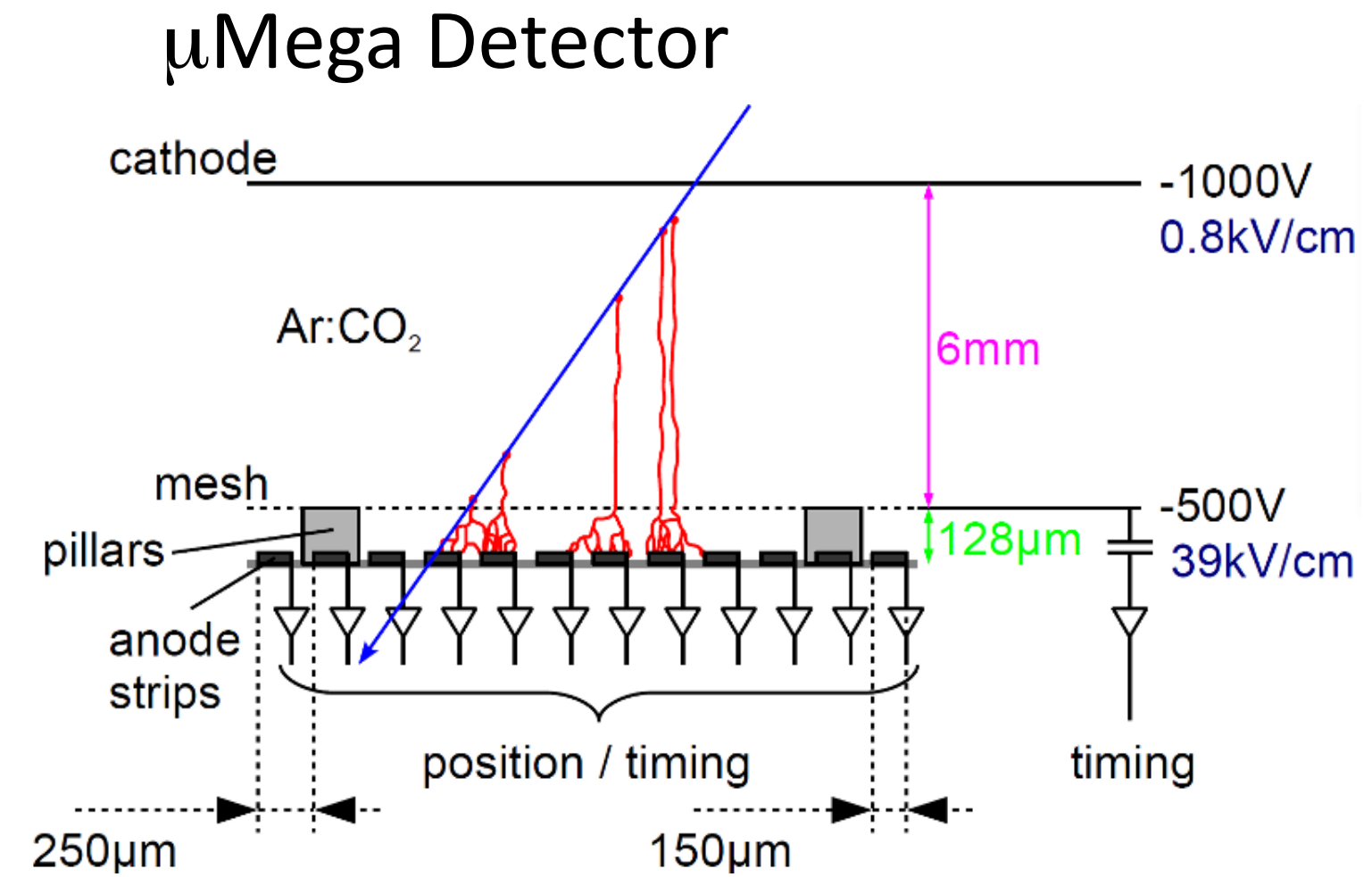

Cylindrical μMega

## Si Tracking/Outer Barrel (2 layers)

- EIC sensors derived from ITS3
  - ▶ not wafer-stitched: too expensive for large area (8 m<sup>2</sup>) due to low yield

## Cylindrical MPGD Layer

- Either Micromegas or Thin Gap MPGDs
- Important for pattern recognition

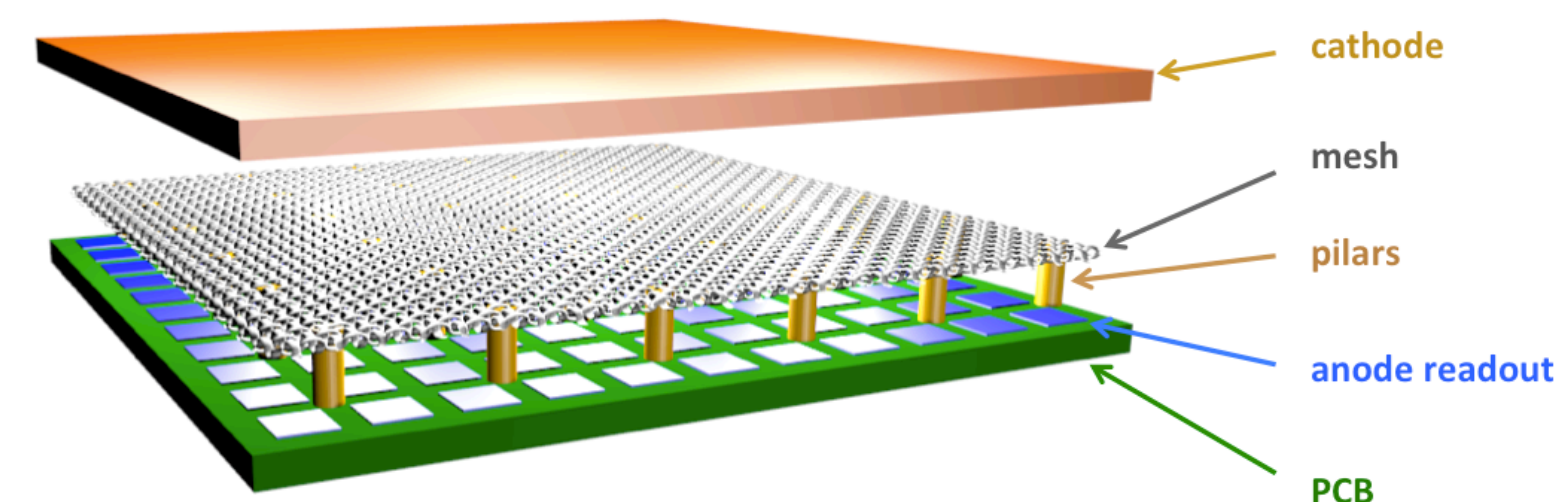

# Barrel Tracking

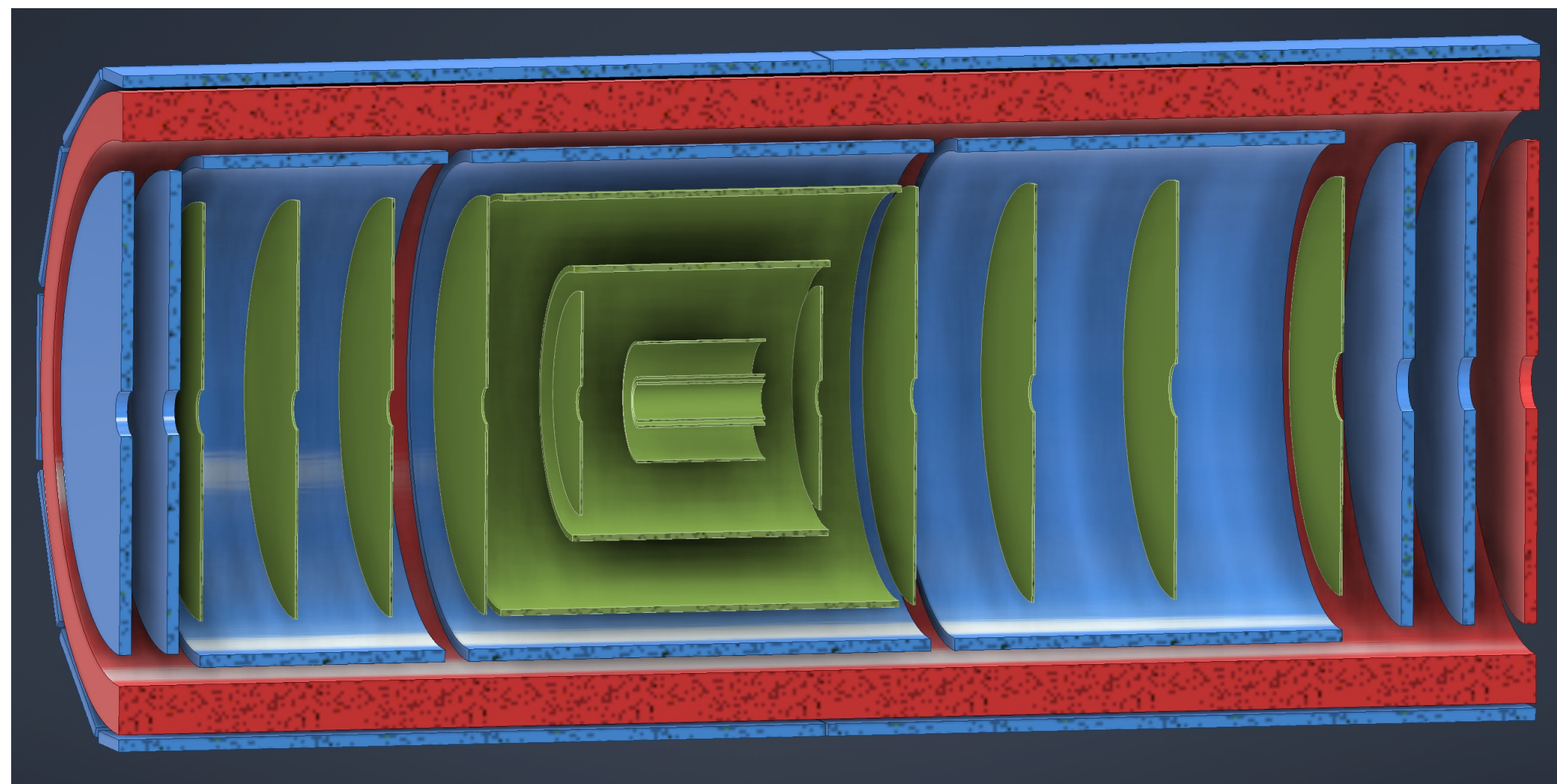

SVT

MPGDs

ToF (fiducial volume)

BTOF

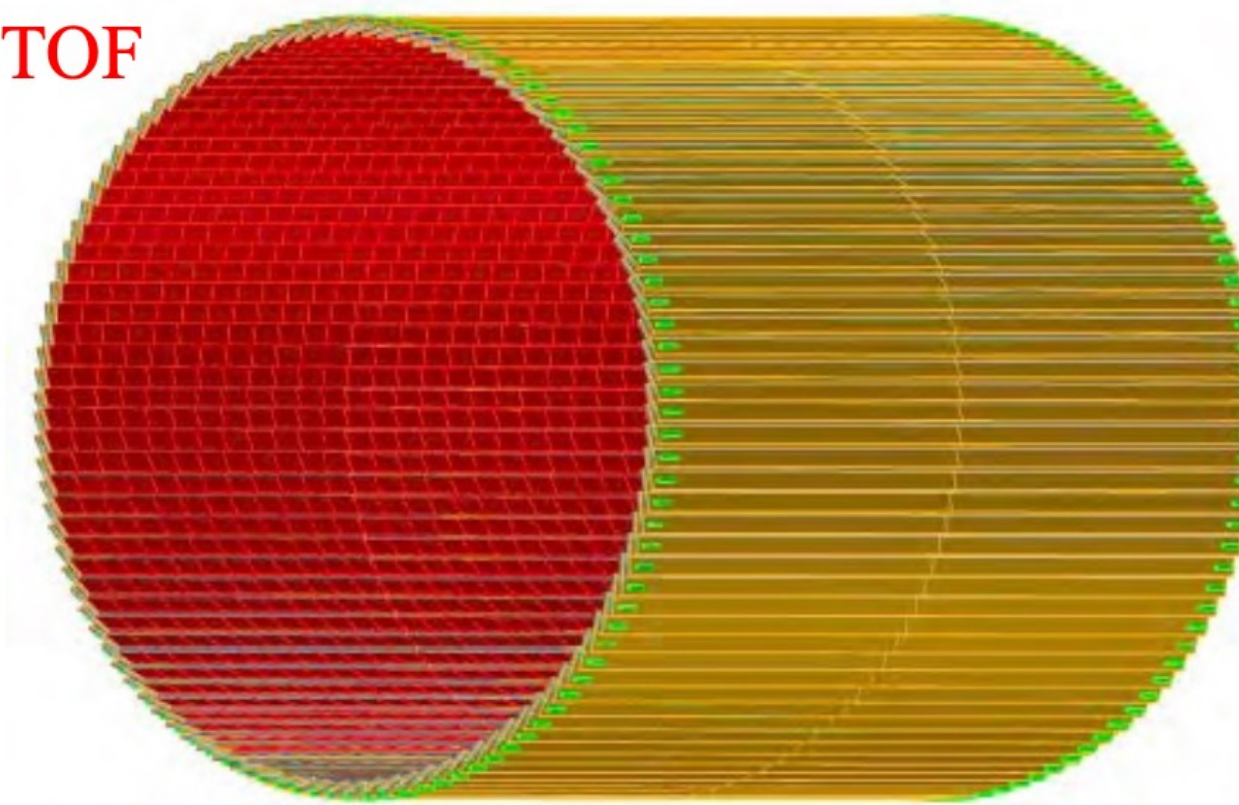

HPK Strip Sensor (4.5x10 mm<sup>2</sup>)

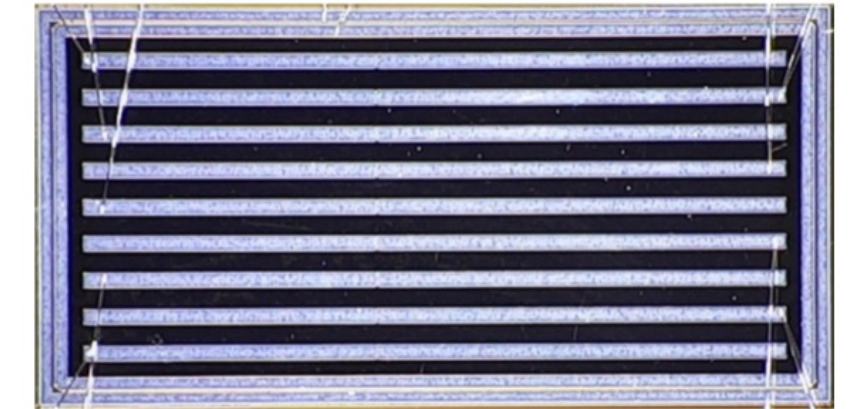

	Area (m <sup>2</sup> )	Channel size (mm <sup>2</sup> )	# of Channels	Timing Resolution	Spatial resolution	Material budget
Barrel TOF	10	0.5*10	2.4M	35 ps	30 $\mu\text{m}$ in $r \cdot \varphi$	0.01 X <sub>0</sub>

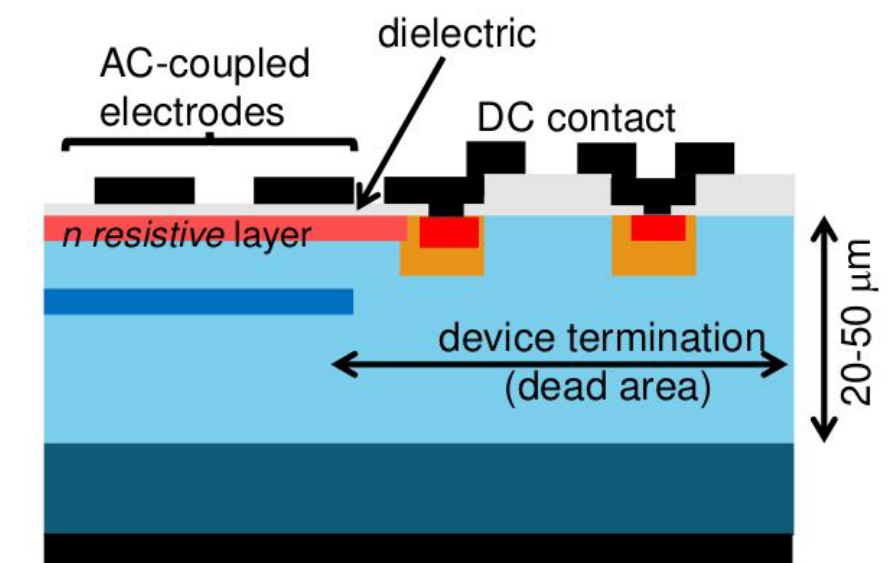

## AC-LGAD TOF

- Serves for tracking and low- $p_T$  PID
- Additional space point for pattern recognition / redundancy

# Forward-Backward Tracking

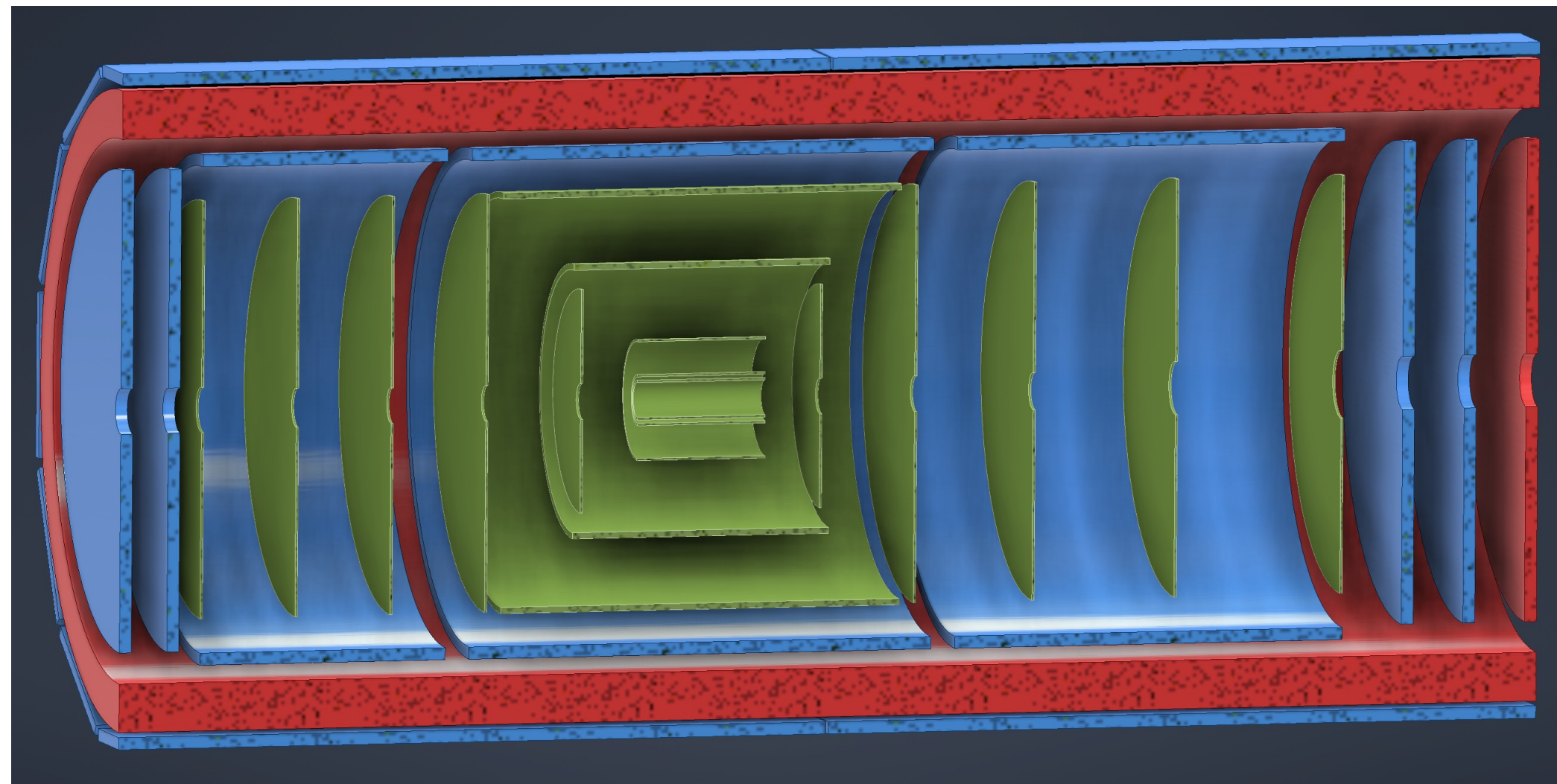

SVT      MPGDs      ToF (fiducial volume)

Disk	-z	+z	X/X <sub>0</sub>
Si 1	250	250	0.24
Si 2	450	450	0.24
Si 3	650	700	0.24
Si 4	850	1000	0.24
Si 5	1050	1350	0.24
MPGD	1100	1480	~1
MPGD	1200	1610	~1

## Disk layout design in progress



- 5 Si + 2  $\mu$ RWell discs in forward/backwards direction (ITS-3 based large area sensor design)
- High resolution requirements hard to meet
  - ▶ Increase lever arm by maximizing tracker extent in z
  - ▶ Pattern recognition with realistic background studied
  - ▶ Ongoing optimization
  - ▶ Can potentially impact  $t$  measurement in e+A

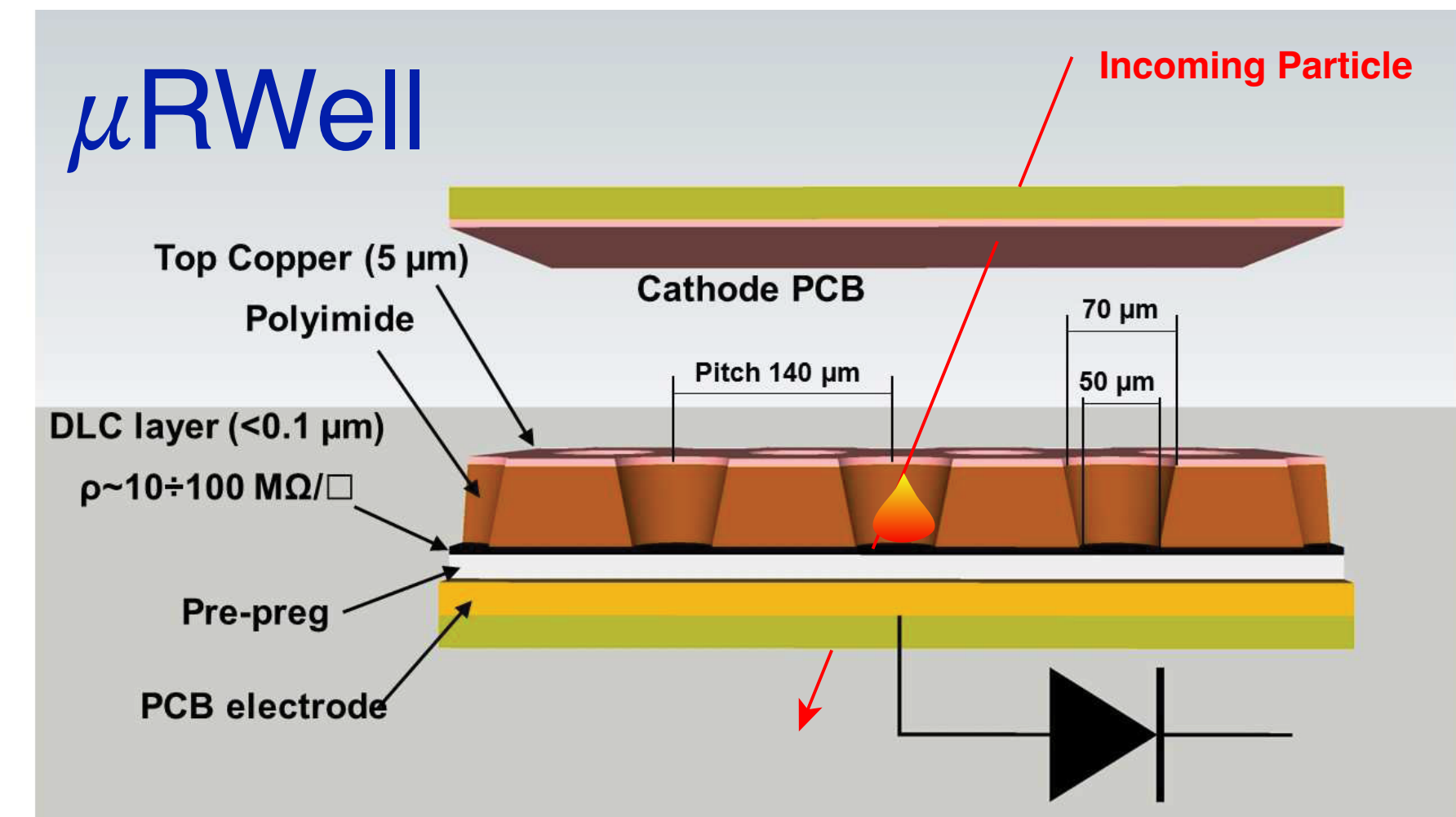

# Forward-Backward Tracking

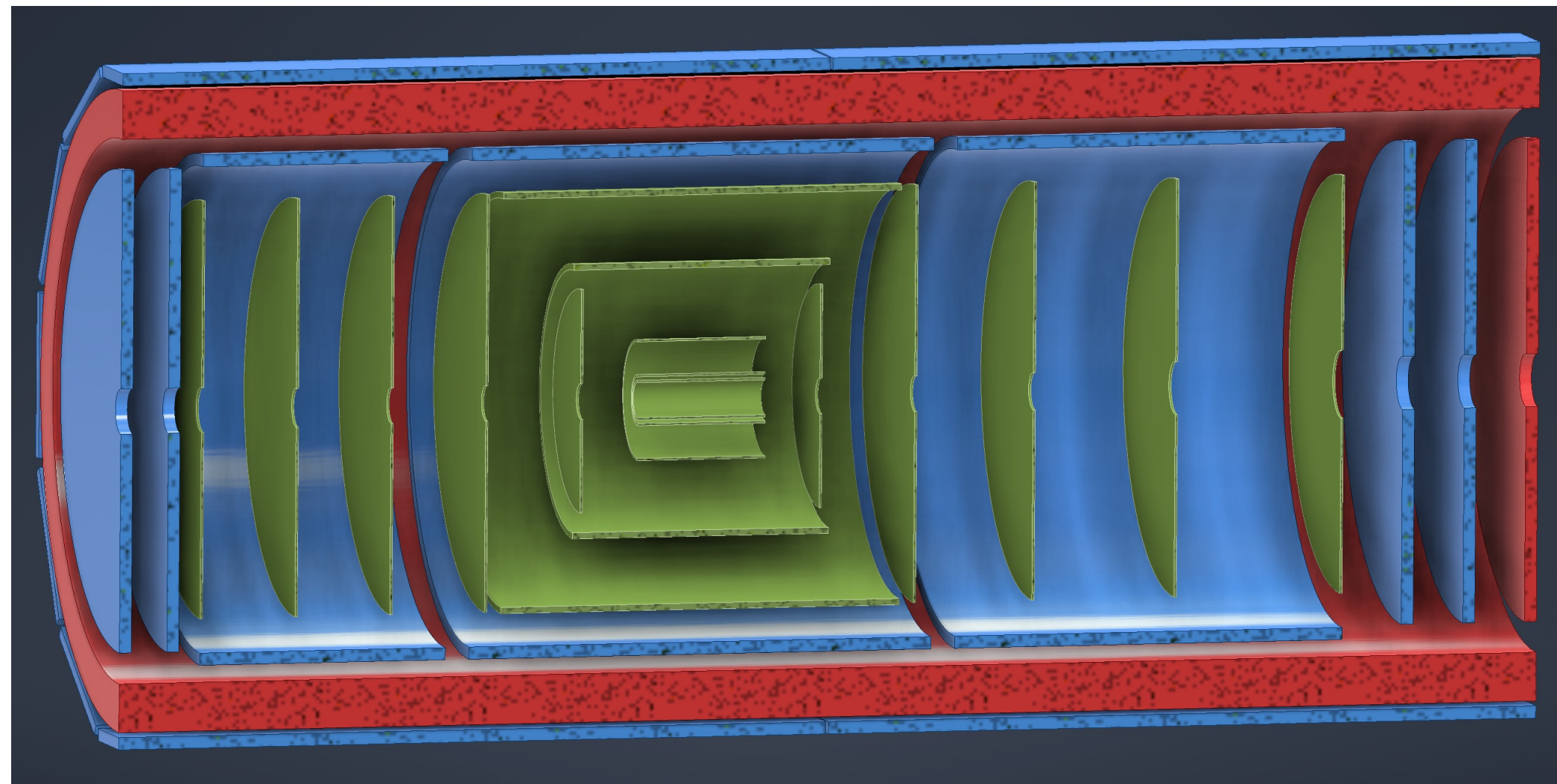

SVT      MPGDs      ToF (fiducial volume)

Disk	-z	+
Si 1	250	
Si 2	450	
Si 3	650	
Si 4	850	
Si 5	1050	
MPGD	1100	
MPGD	1200	

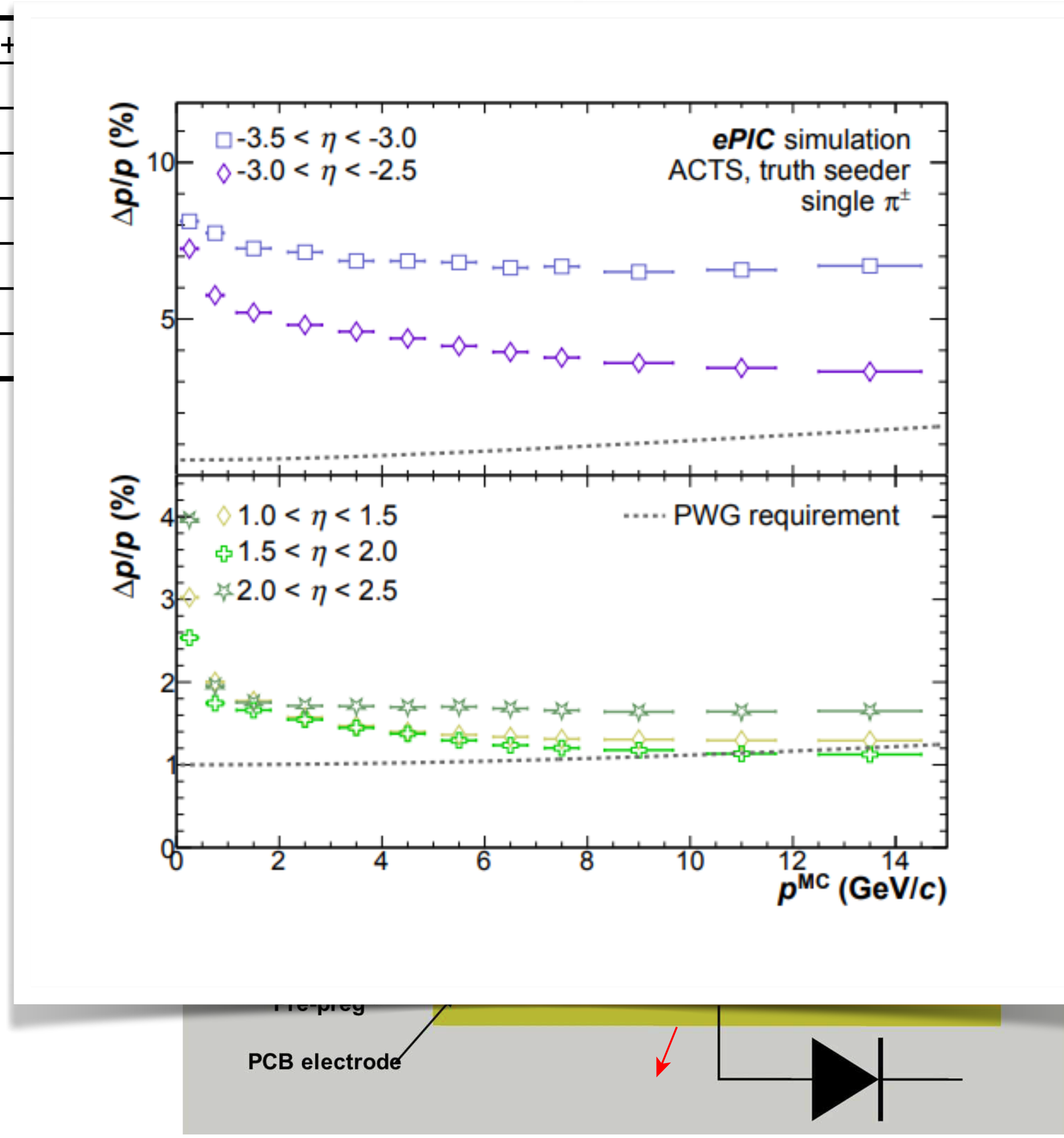

- 5 Si + 2  $\mu$ RWell discs in forward/backwards direction (ITS-3 based large area sensor design)
- High resolution requirements hard to meet
  - ▶ Increase lever arm by maximizing tracker extent in z
  - ▶ Pattern recognition with realistic background studied
  - ▶ Ongoing optimization
  - ▶ Can potentially impact  $t$  measurement in e+A

# Tracking Performance

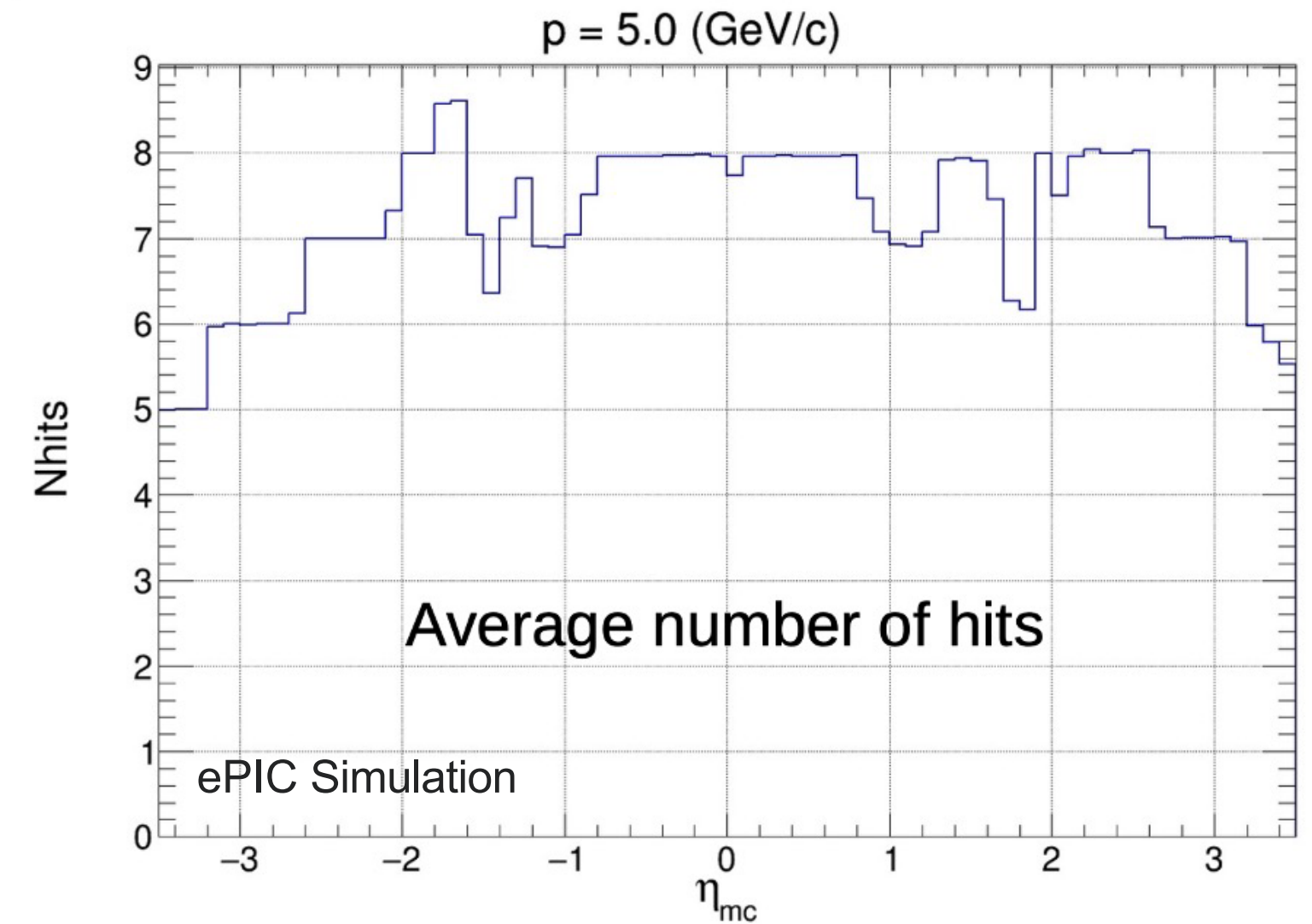
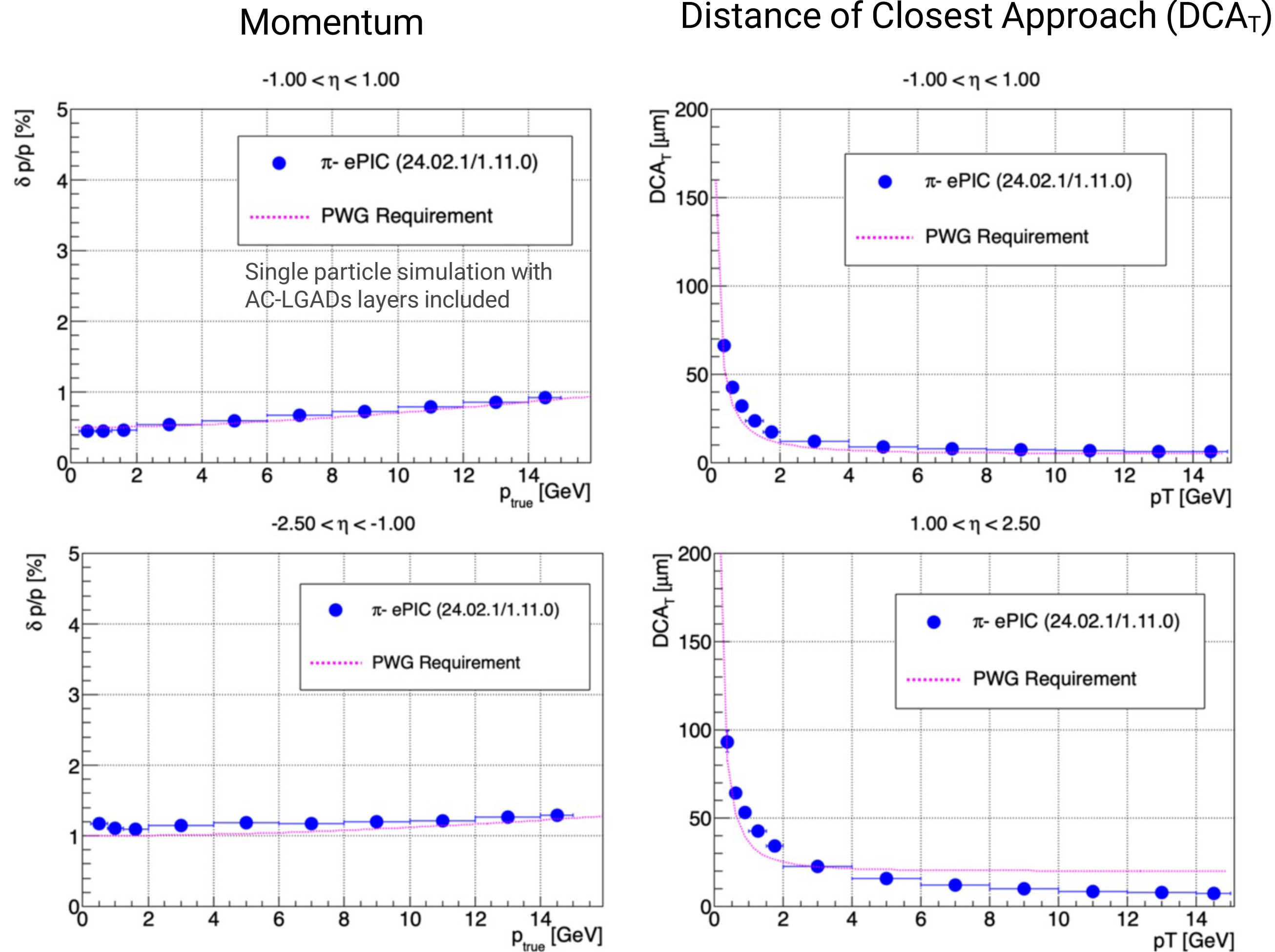

	Momentum Resolution	Spatial Resolution
Backward (-3.5 to -2.5)	$\sim 0.10\% \times p \oplus 2.0\%$	$\sim 30/pT \mu\text{m} \oplus 40 \mu\text{m}$
Backward (-2.5 to -1.0)	$\sim 0.05\% \times p \oplus 1.0\%$	$\sim 30/pT \mu\text{m} \oplus 20 \mu\text{m}$
Barrel (-1.0 to 1.0)	$\sim 0.05\% \times p \oplus 0.5\%$	$\sim 20/pT \mu\text{m} \oplus 5 \mu\text{m}$
Forward (1.0 to 2.5)	$\sim 0.05\% \times p \oplus 1.0\%$	$\sim 30/pT \mu\text{m} \oplus 20 \mu\text{m}$
Forward (2.5 to 3.5)	$\sim 0.10\% \times p \oplus 2.0\%$	$\sim 30/pT \mu\text{m} \oplus 40 \mu\text{m}$

- Backward/Forward momentum resolution in extreme  $\eta$  regions complemented by calorimetric resolution
- Meets PWG requirements elsewhere

# Calorimetry

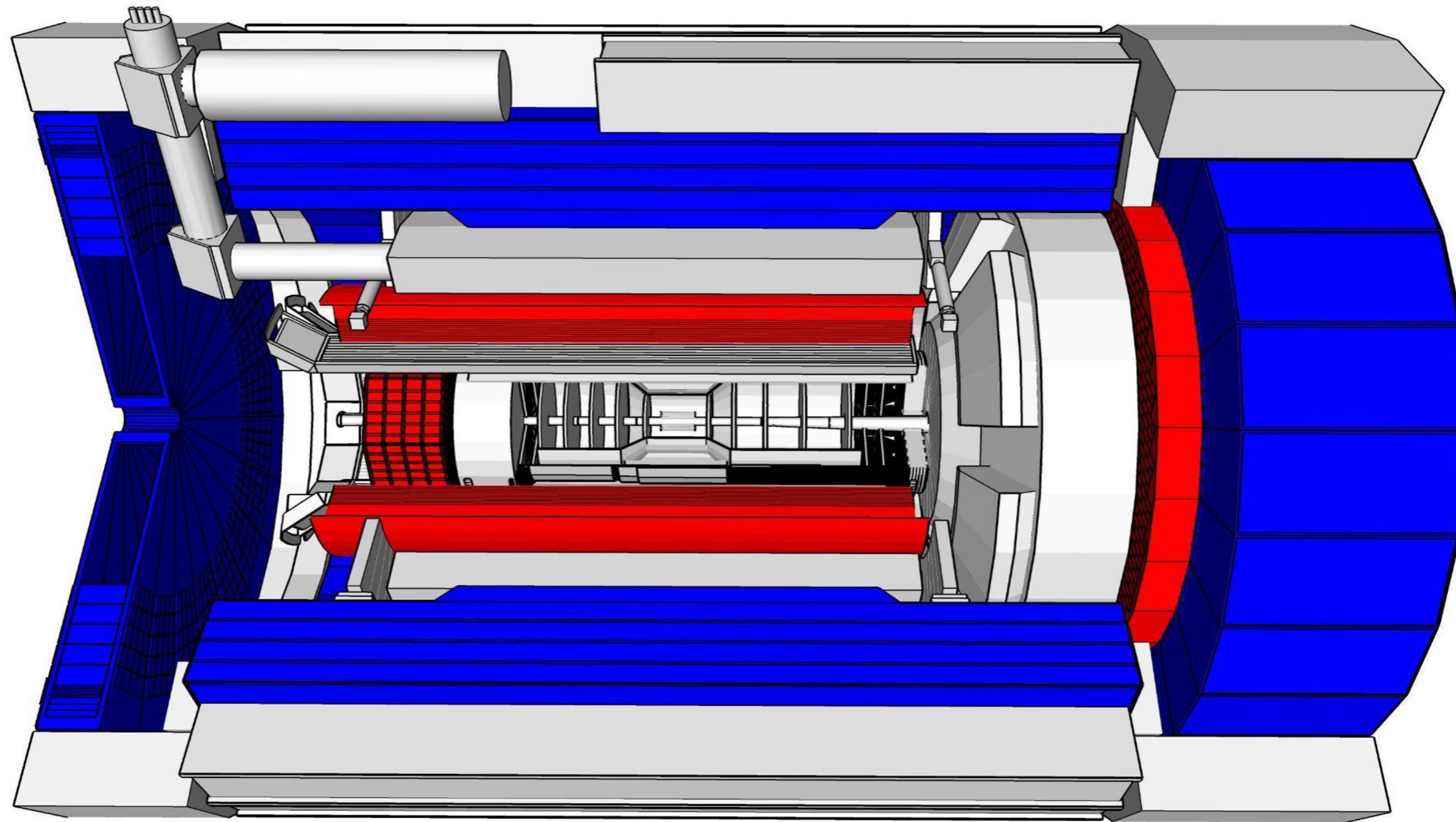

Calorimeters with wide range of acceptances (backward, barrel, forward) and different technologies:

- **Electromagnetic Calorimeter.**
- **Hadronic Calorimeter.**

## Purpose:

- Detect the scattered electron and separate them from  $\pi$  (up to  $10^{-4}$  suppression factor in backward and barrel ECal)
- Improve the electron momentum resolution at backward rapidities ( $2-3\% \sqrt{E} \oplus (1-2)\%$  for backward ECal)
- Provide spatial resolution of two photons sufficient to identify decays  $\pi^0 \rightarrow \gamma\gamma$  at high energies from ECals
- Contain the highly energetic hadronic final state and separate clusters in a dense hadronic environment in Forward ECal and HCal

# Electromagnetic Calorimetry

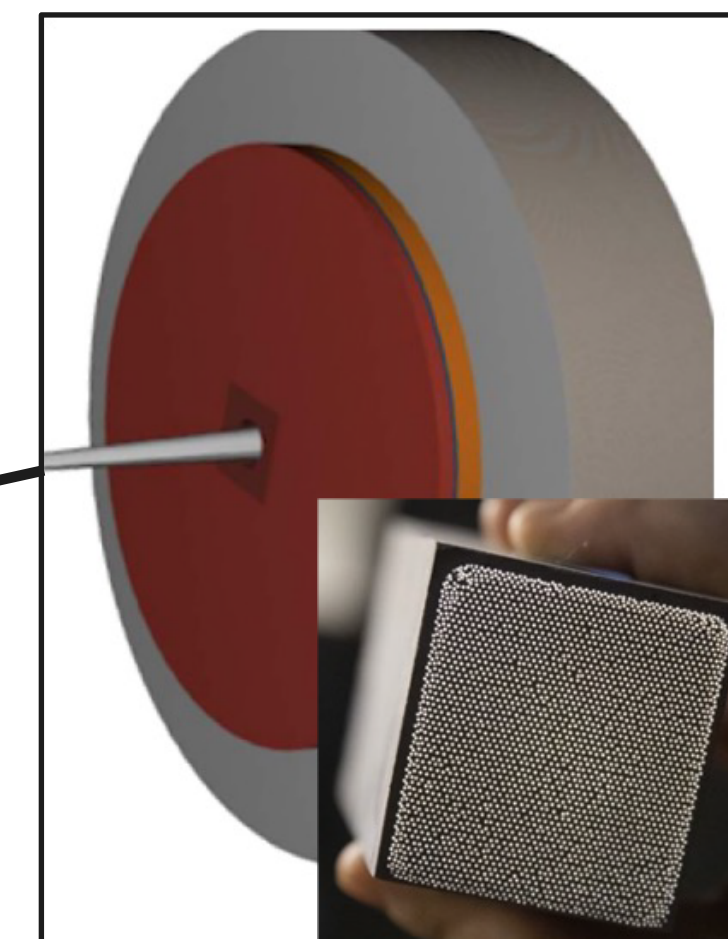
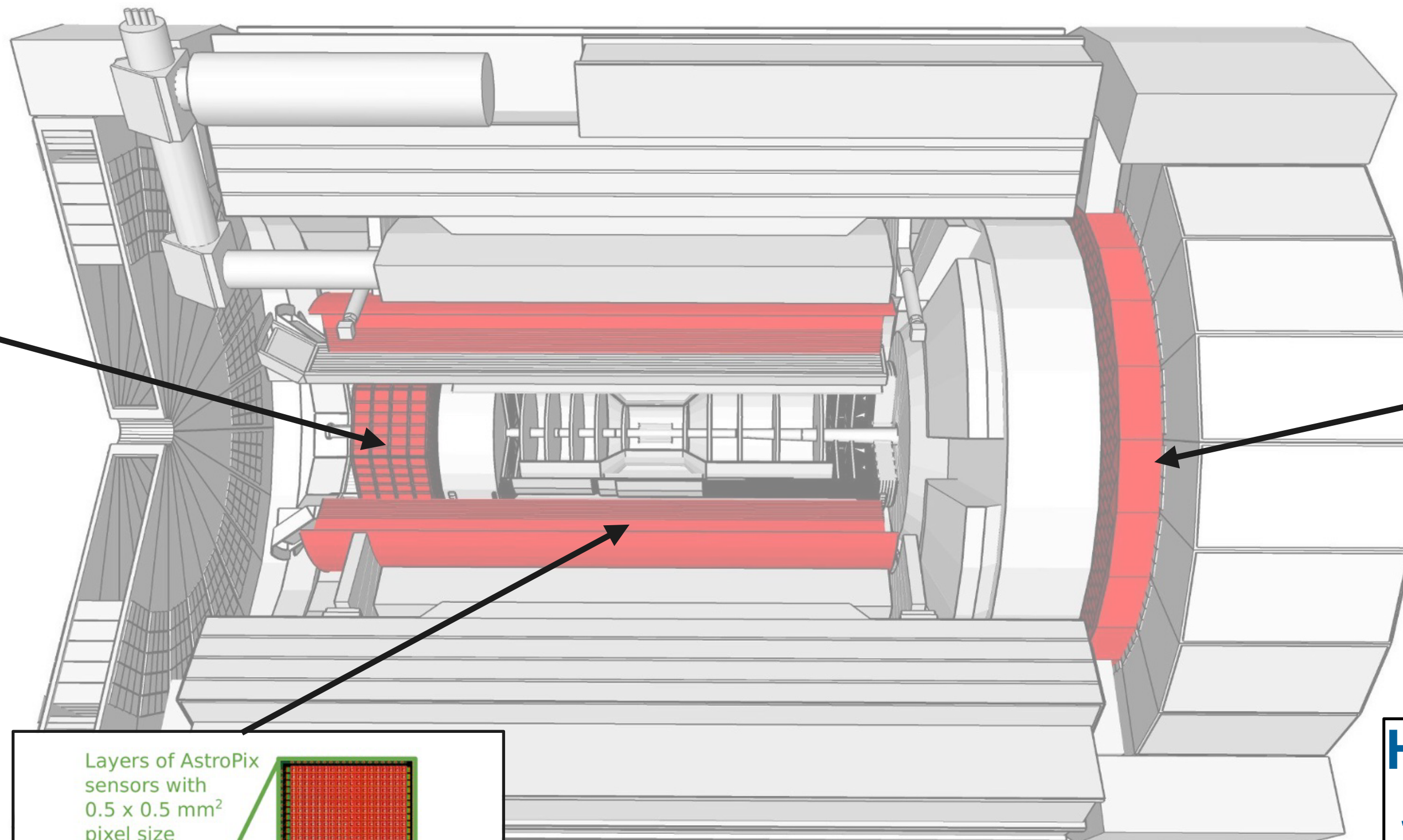
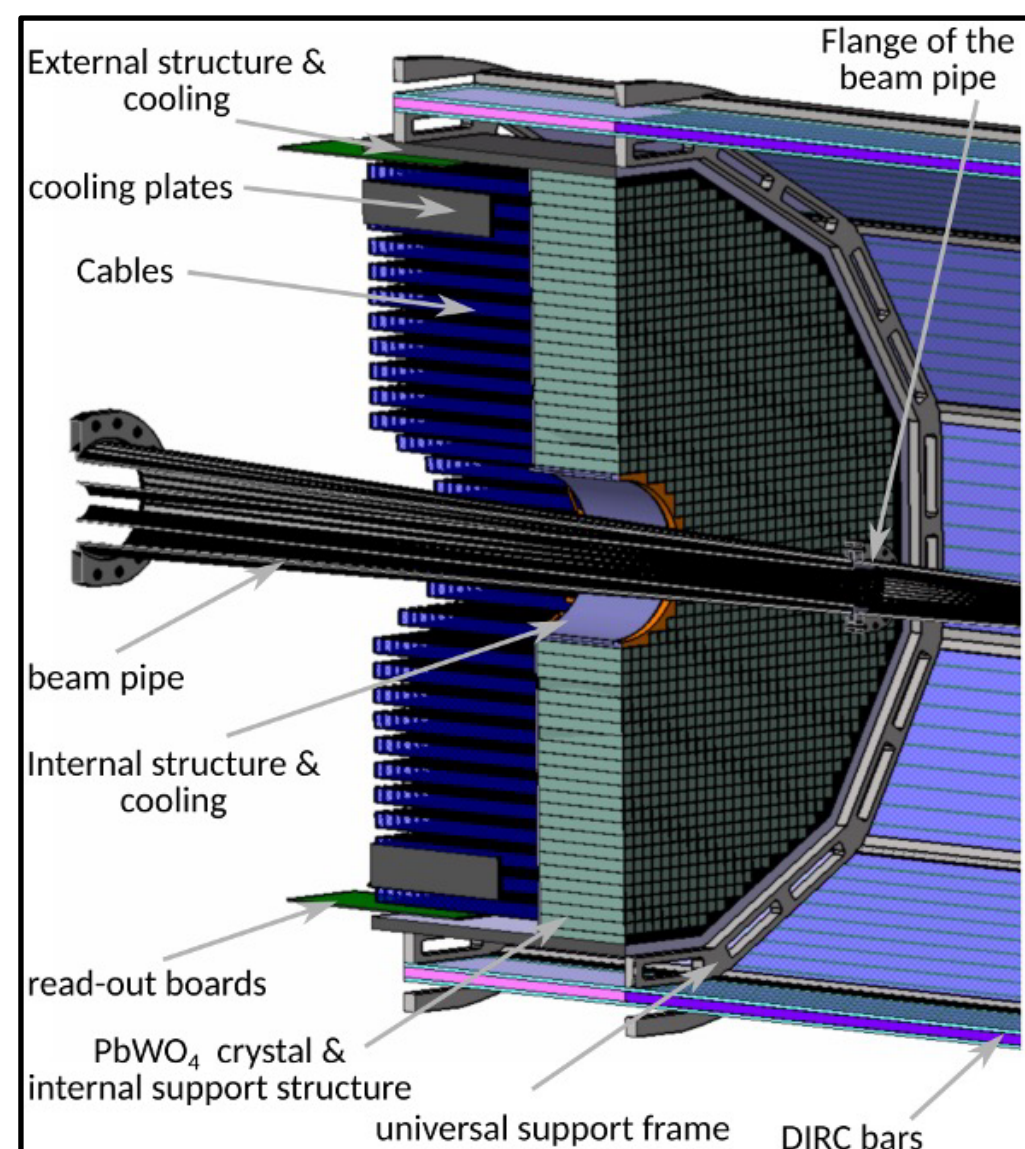

## Backward EMCal PbWO<sub>4</sub> crystals

- 2 × 2 × 20 cm<sup>3</sup> crystals
- Readout: SiPMs  
10 μm pixel
- Depth: ~20 X<sub>0</sub>
- Cooling to keep temperature stable within ± 0.1 °C

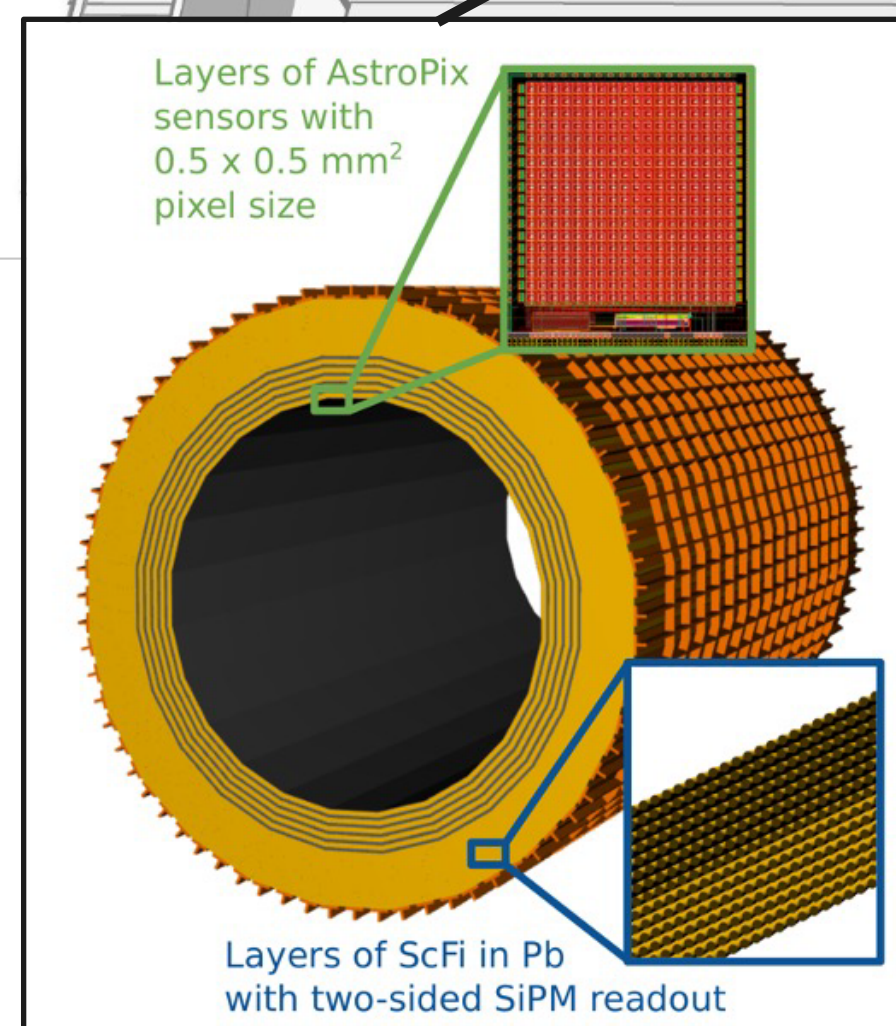

## Imaging Barrel Calorimeter

- 4(+2) layers of AstroPix MAPS sensor, 500x500 μm
- Interleaved with scintillating fiber/Pb layers
  - 2-side SiPM readout, 50 μm pixel
- Depth: ~17.1 X<sub>0</sub>

## High granularity W/ SciFi EMCal

- Tungsten powder mixed with epoxy + scintillating fibers
- 5 cm x 5 cm x 17 cm blocks
- 4 independent towers per block
- Readout: 4 SiPM per tower, 50 μm pixel
- Depth: ~23 X<sub>0</sub>

# Hadronic Calorimetry

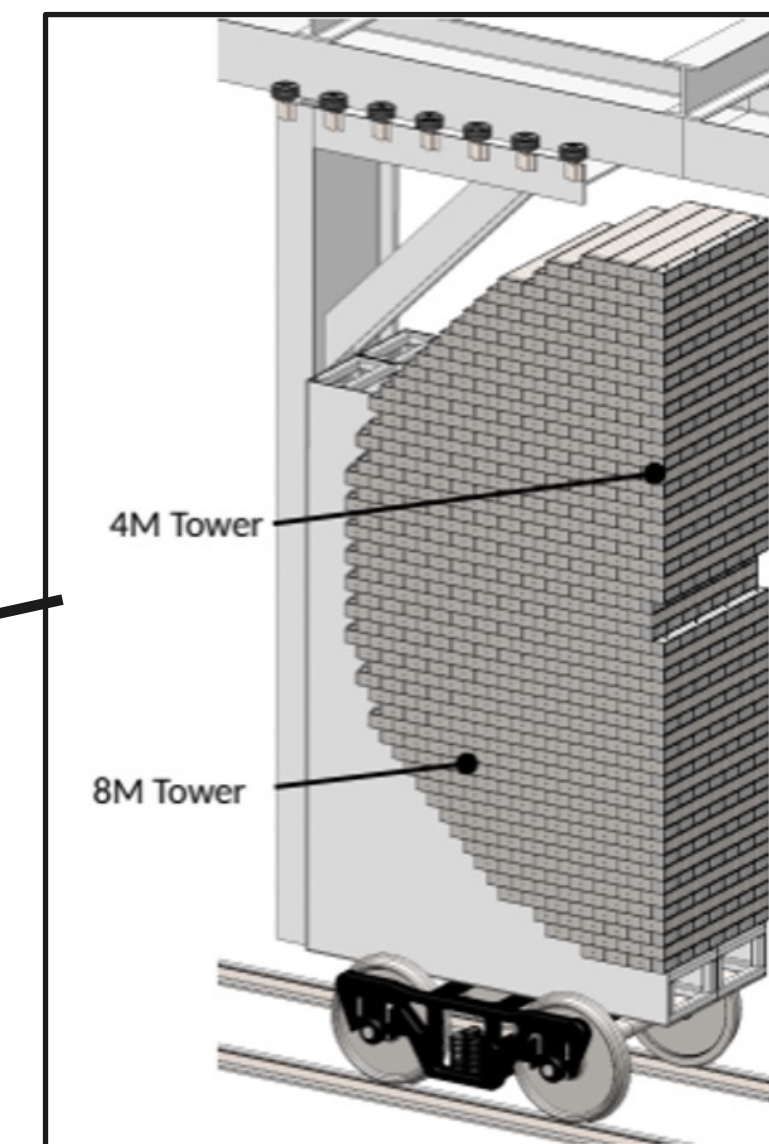
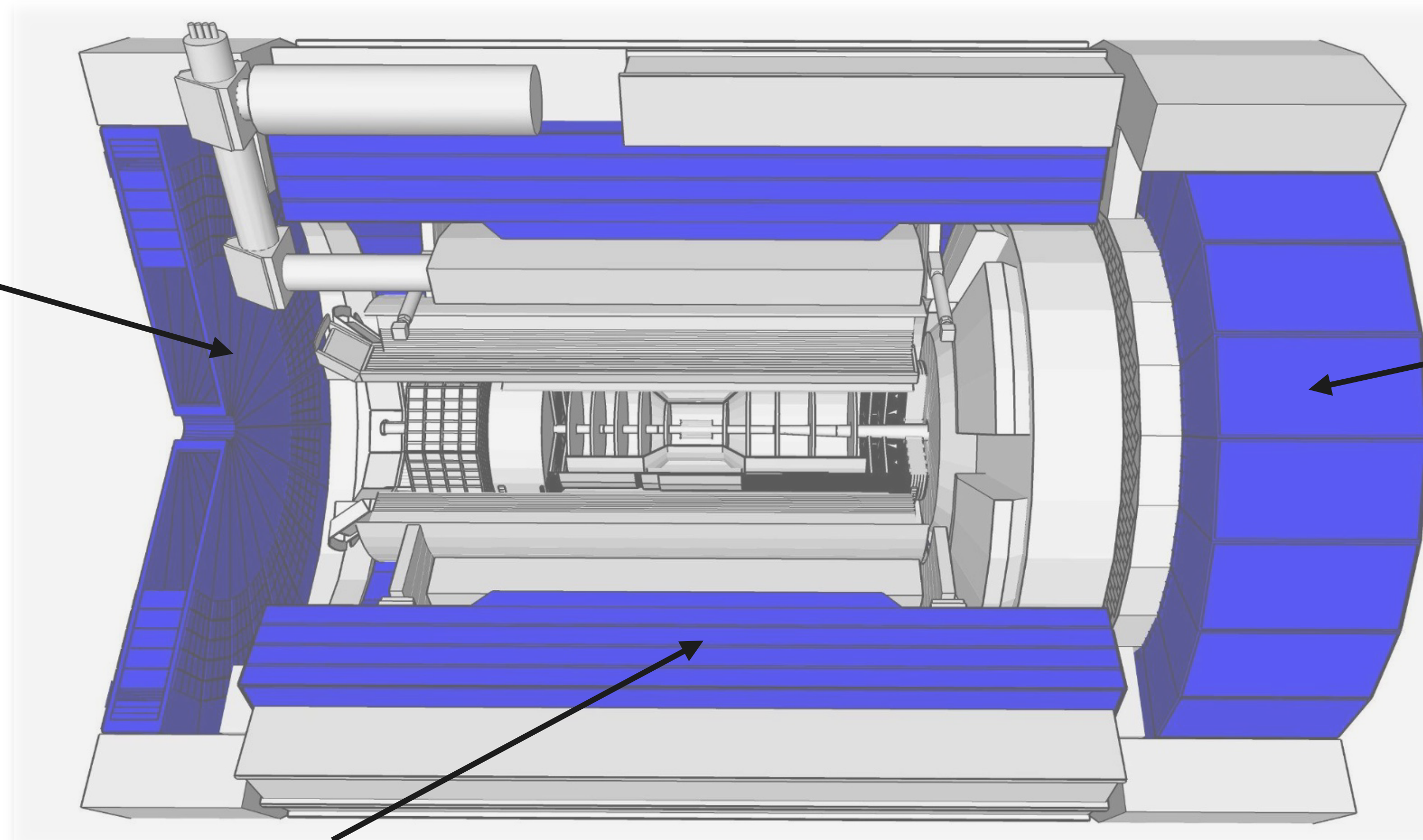
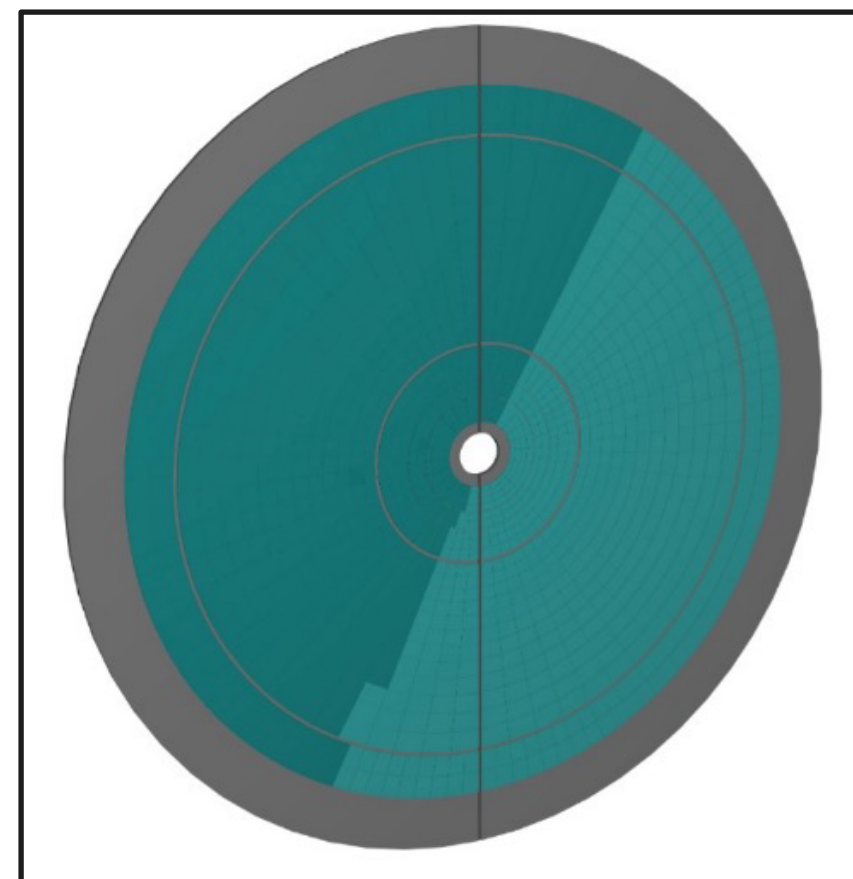

## Backwards HCal

- Steel + large scintillator tiles sandwich
- SiPM readout
- Exact design still in progress



## Barrel HCal (sPHENIX re-use)

- Tilted Steel/Scintillator plates with SiPM readout
- Refurbish for EIC
- Minor radiation damage replace SiPMs
  - Upgrade electronics to HGCROC
  - Reading out each tile individually

## Longitudinally separated HCal with high- $\eta$ insert

- Steel + Scintillator SiPM-on-tile
- Highly segmented longitudinally
- 65 layers per tower
  - 565,760 SiPMs
- Stackable for “easy” construction

# Particle ID (PID)

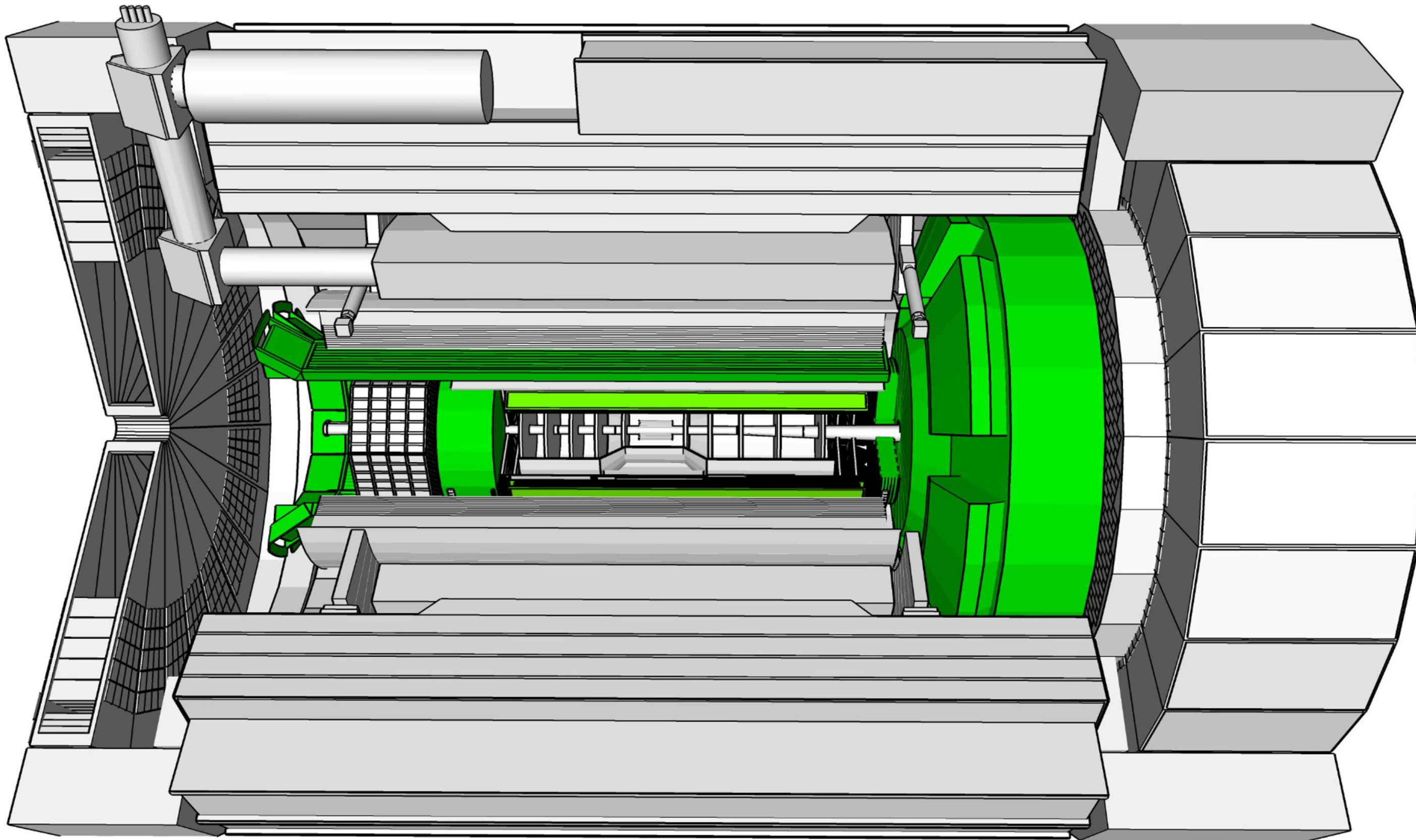

## Particle Separation Needs

- Electrons from photons  $\rightarrow 4\pi$  coverage in tracking
- Electrons from charged hadrons  $\rightarrow$  mostly provided by calorimetry and tracking, PID detectors at low  $p$
- Charged pions, kaons and protons from each other on track level  $\rightarrow$  **Cherenkov detectors**
- Cherenkov detectors, complemented by other technologies **at lower momenta: ToF**
- **Demands on PID are unique to ePIC**

Rapidity	$\pi/K/p$ and $\pi^0/\gamma$	e/h	Min $p_T$ (E)
-3.5 - -1.0	7 GeV/c	18 GeV/c	100 MeV/c
-1.0 - 1.0	8-10 GeV/c	8 GeV/c	100 MeV/c
1.0 - 3.5	50 GeV/c	20 GeV/c	100 MeV/c

# Particle ID (PID)

## High-Performance DIRC (hpDIRC)

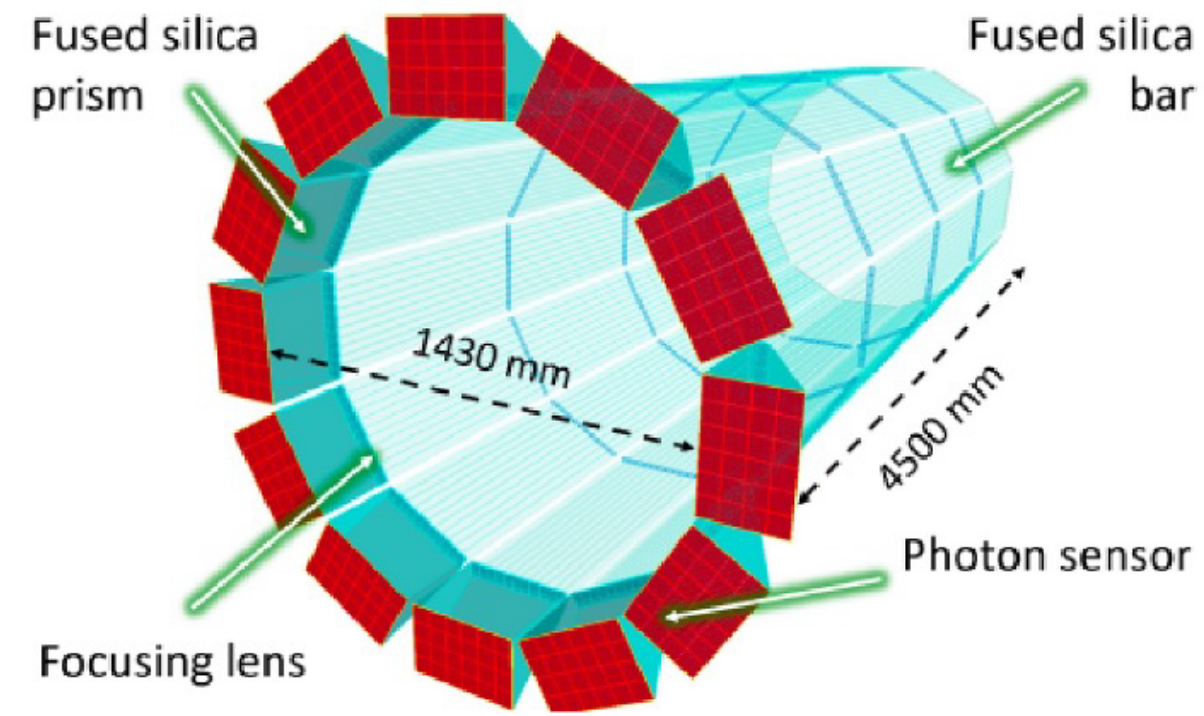

## Dual-Radiator RICH (dRICH)

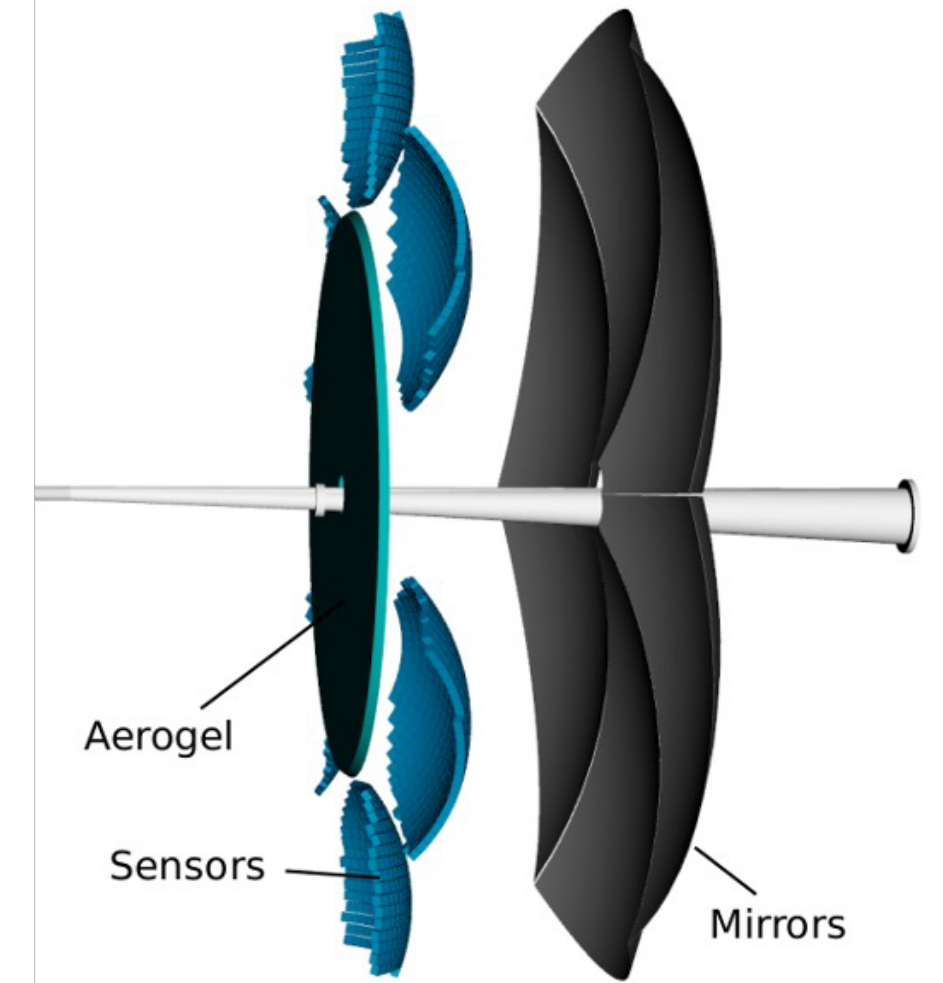

## Time-of-Flight (ToF)

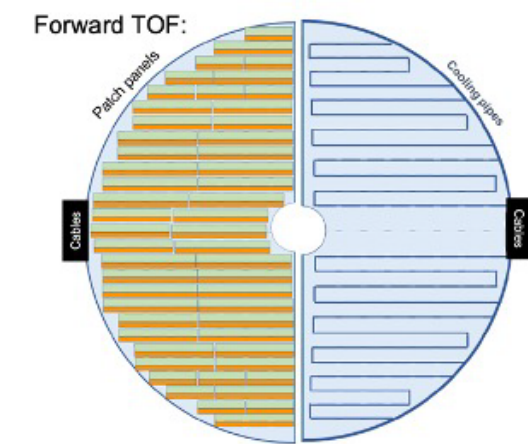

## Proximity Focusing RICH (pfRICH)

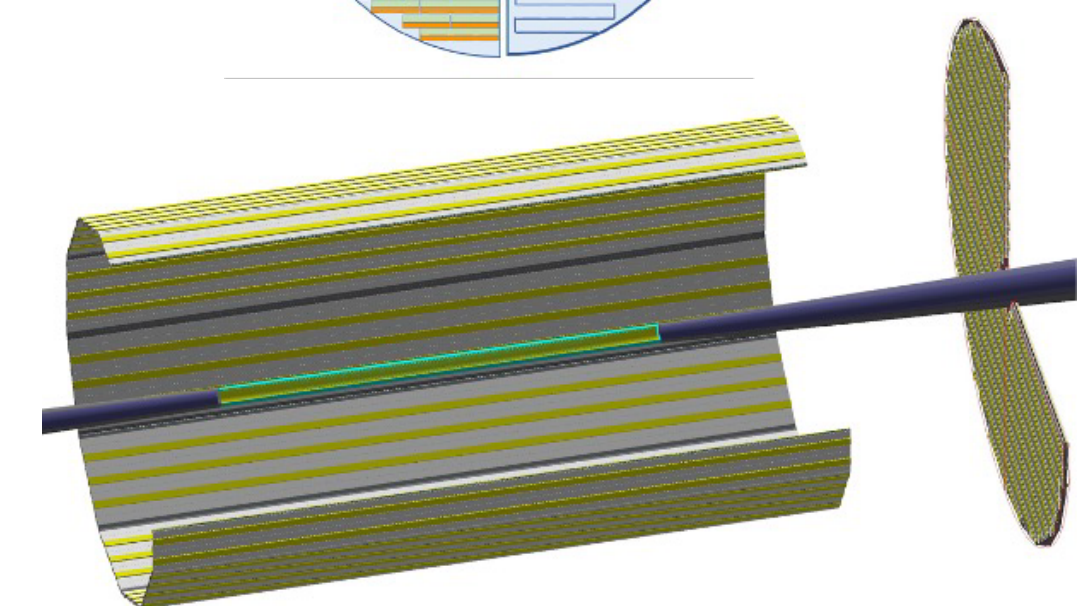
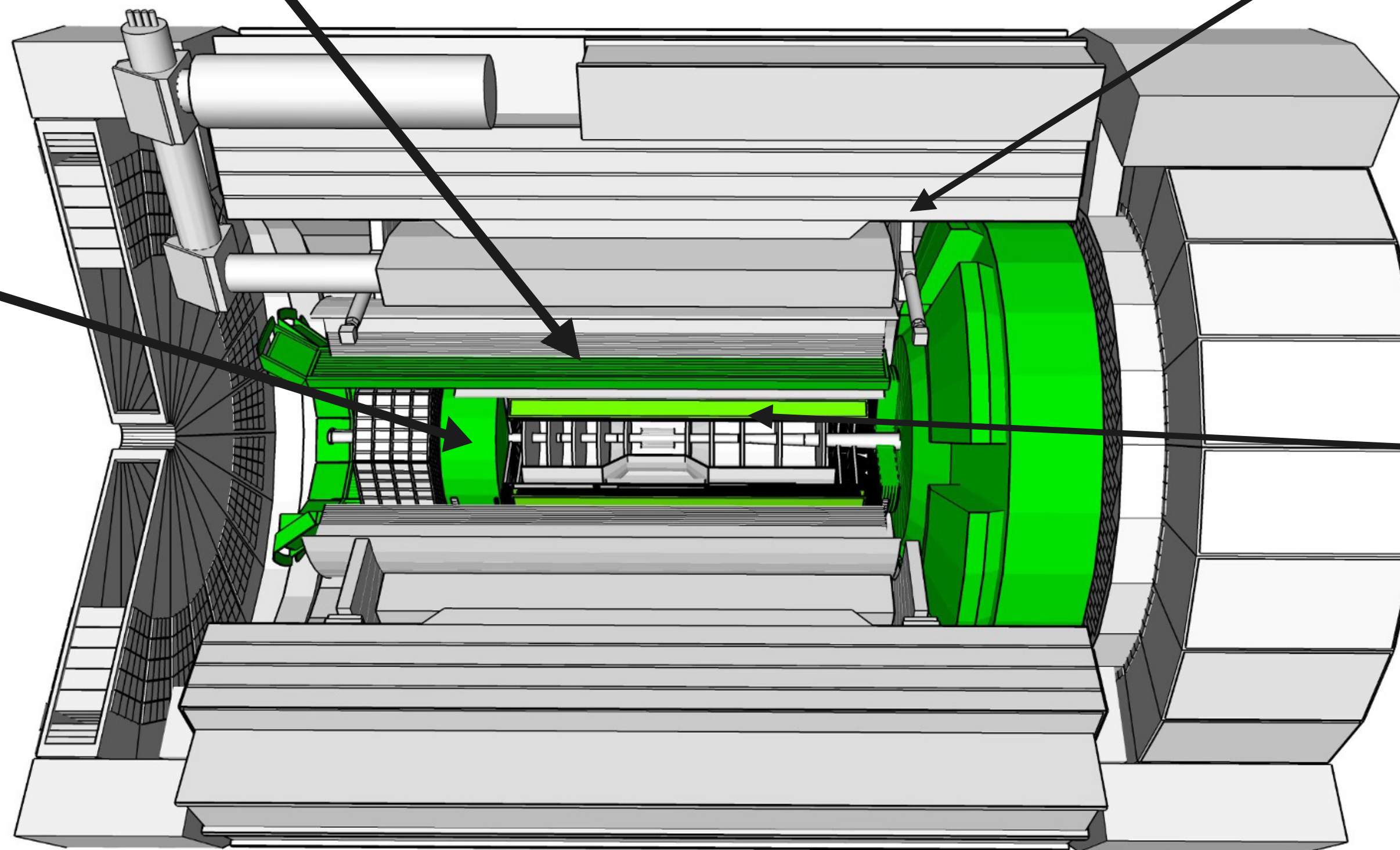
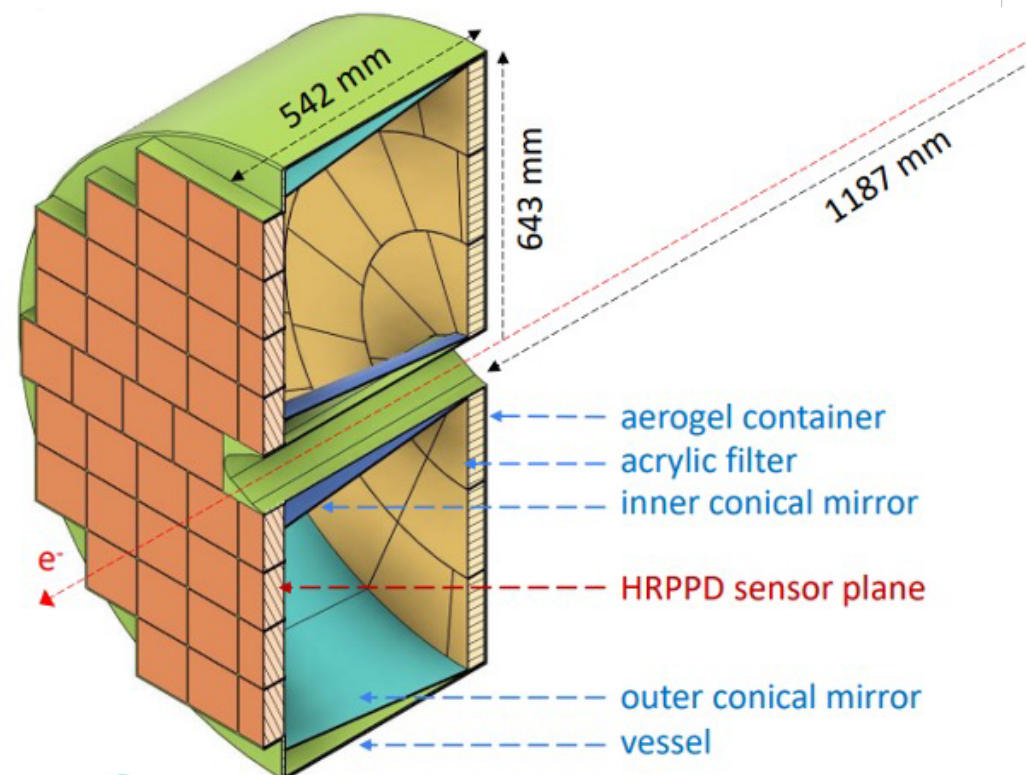

# Are we done?

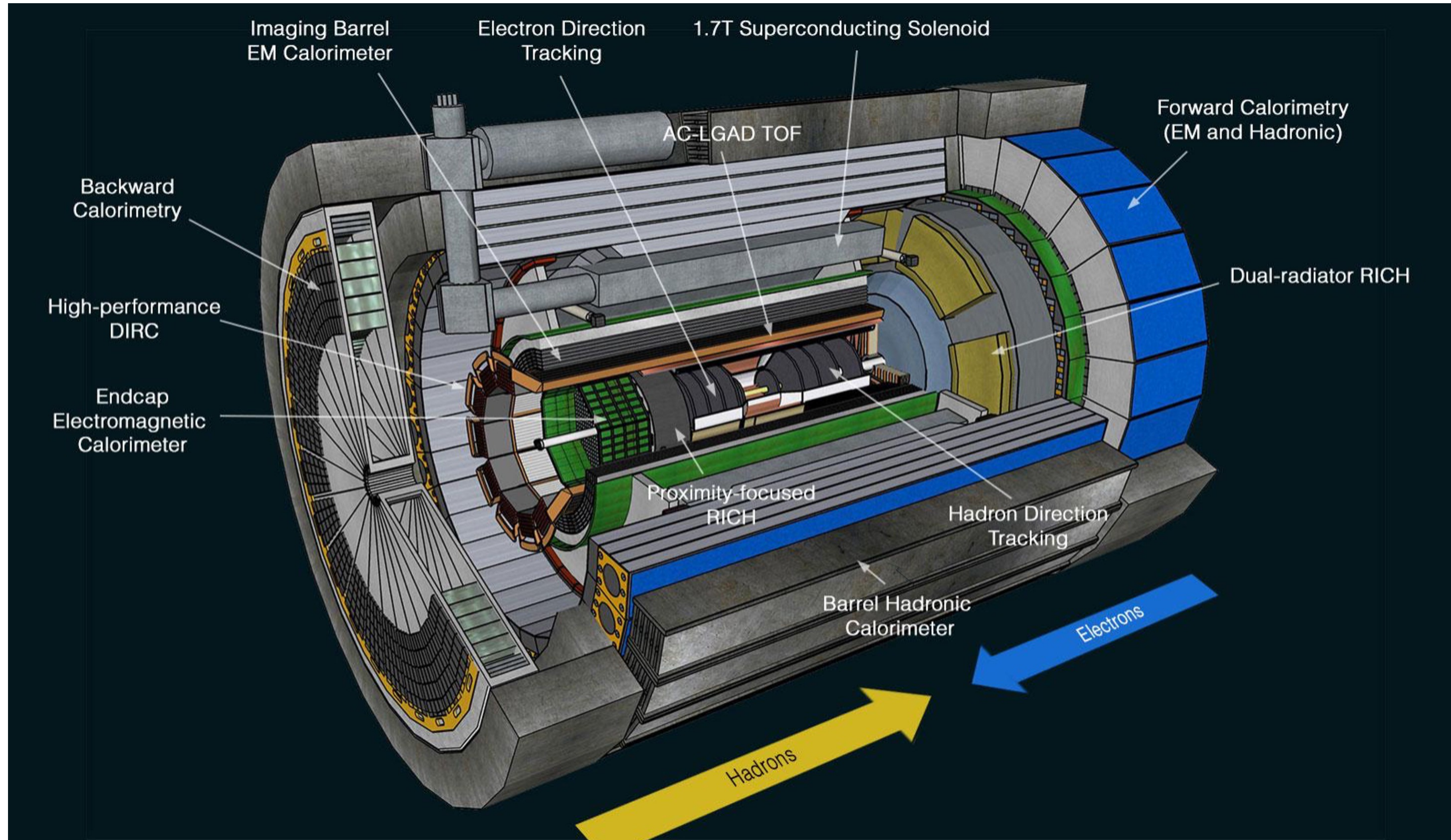

# Are we done?

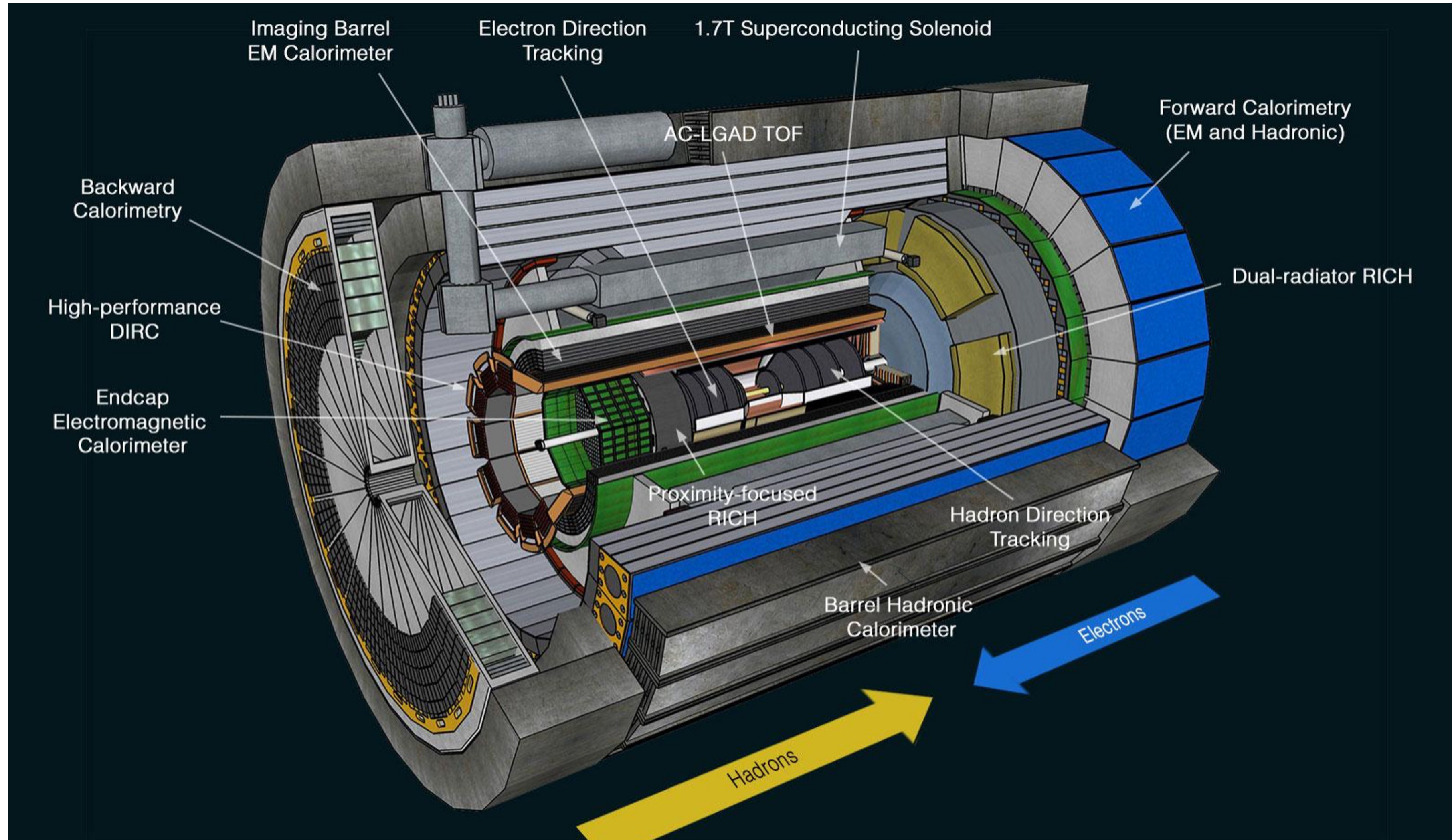

Perfect and necessary, but not sufficient ...

# ePIC Far-Forward/Far-Backward Detectors

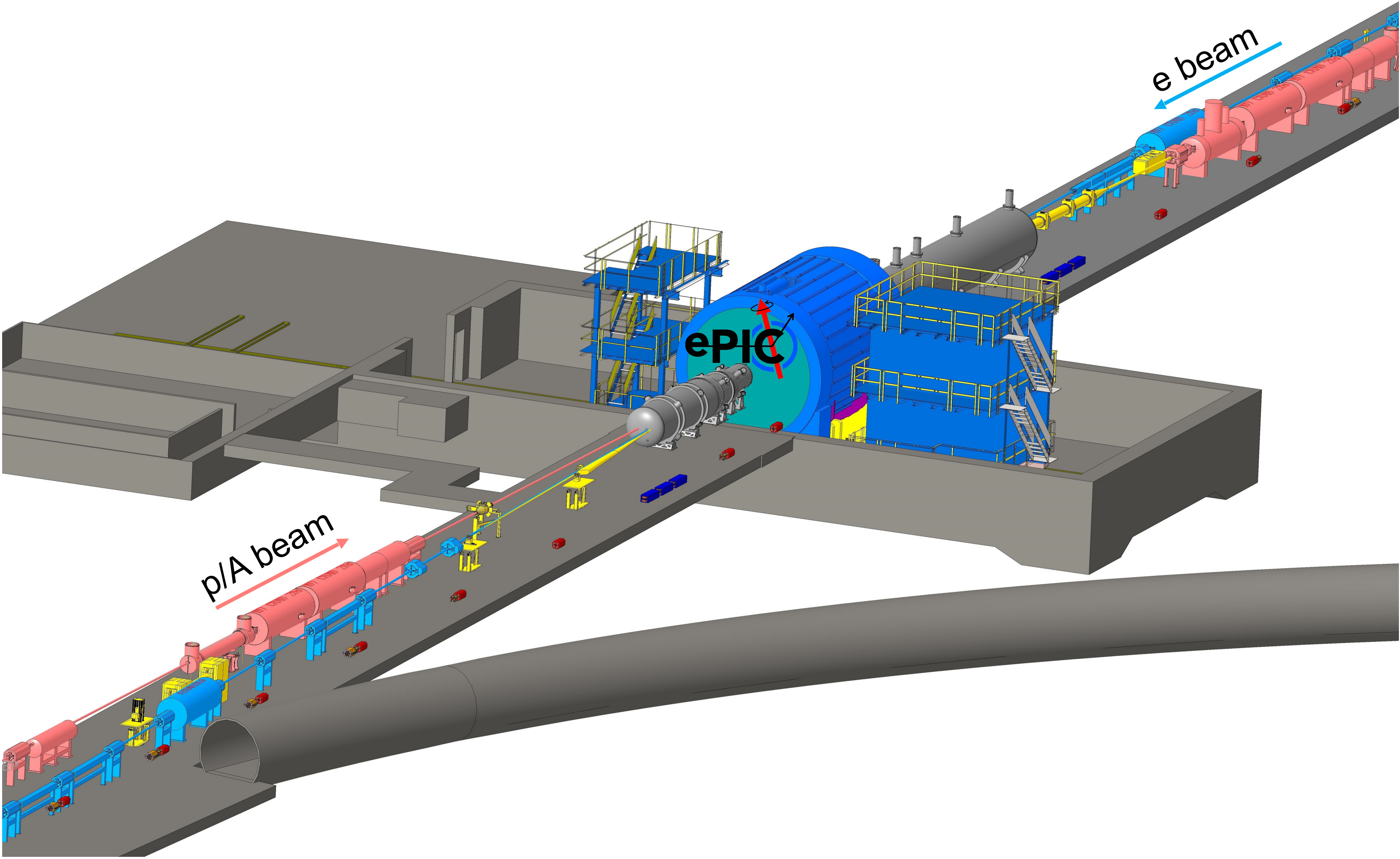

# ePIC Far-Forward/Far-Backward Detectors

**Main Function:**  
measure bunch-by-bunch luminosity  
through Bethe-Heitler  
process

**Technology:**  
Pair-spectrometer: each  
with 2 tracking layers of  
AC-LGAD / FCFD

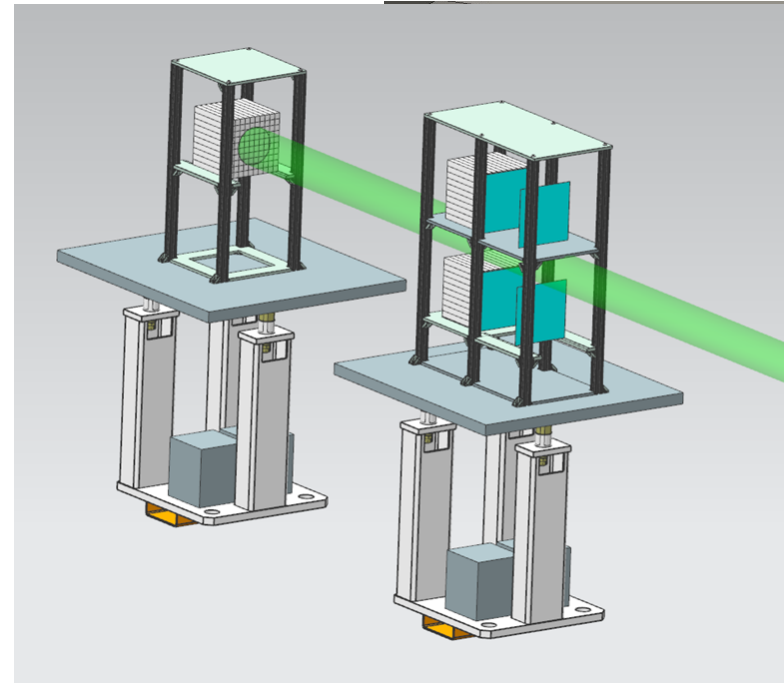

**Luminosity System**

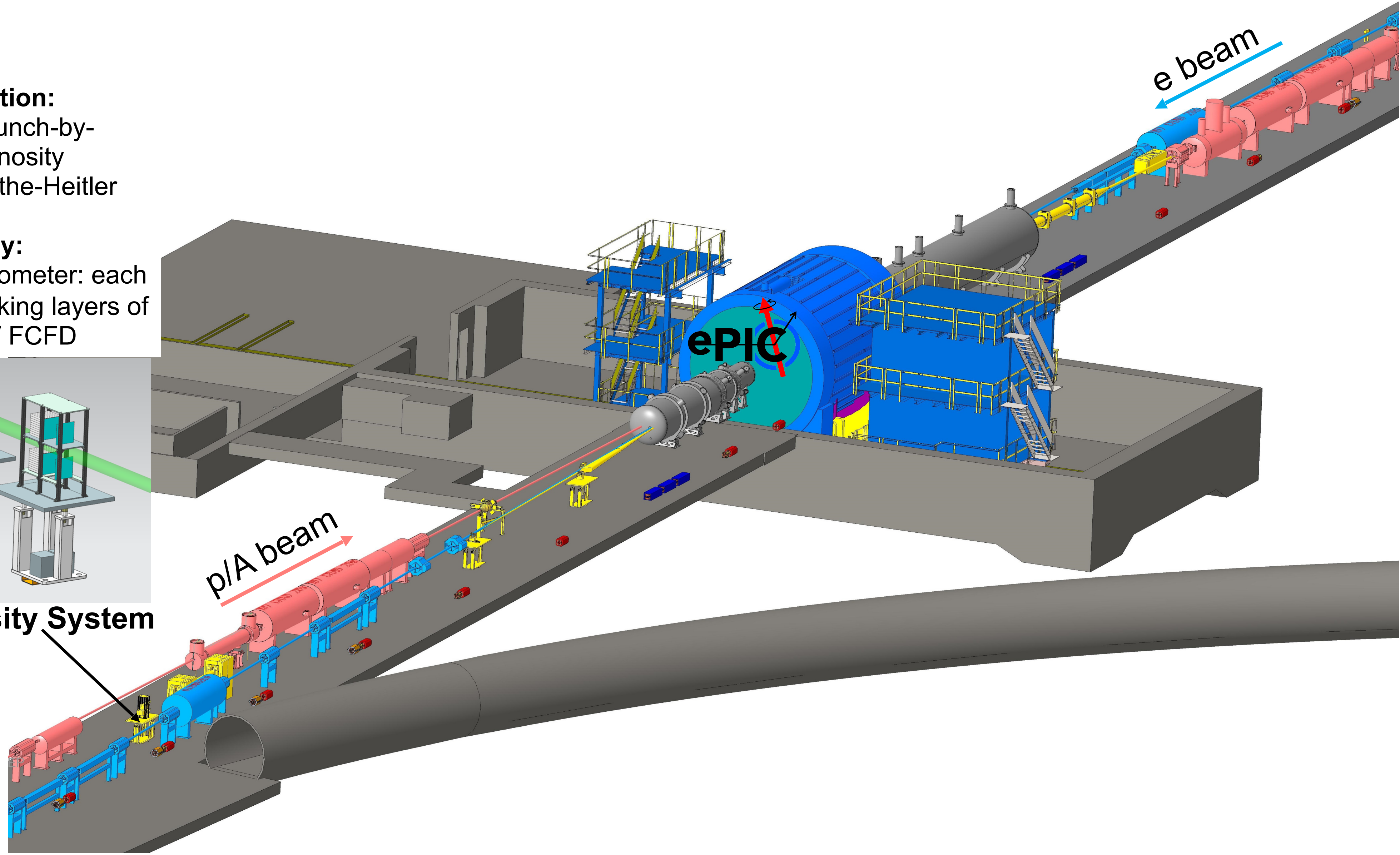

# ePIC Far-Forward/Far-Backward Detectors

**Main Function:**  
measure bunch-by-bunch luminosity  
through Bethe-Heitler  
process

**Technology:**  
Pair-spectrometer: each  
with 2 tracking layers of  
AC-LGAD / FCFD

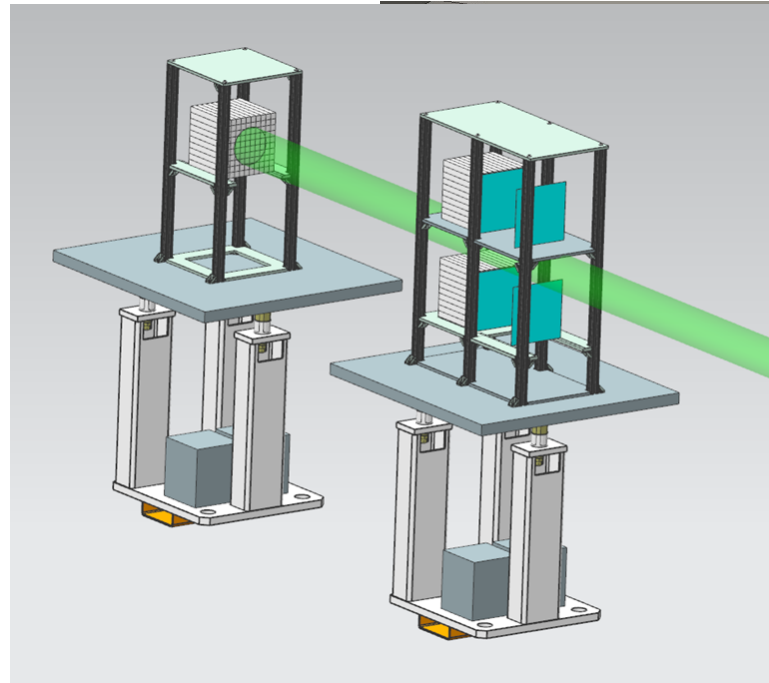

**Luminosity System**

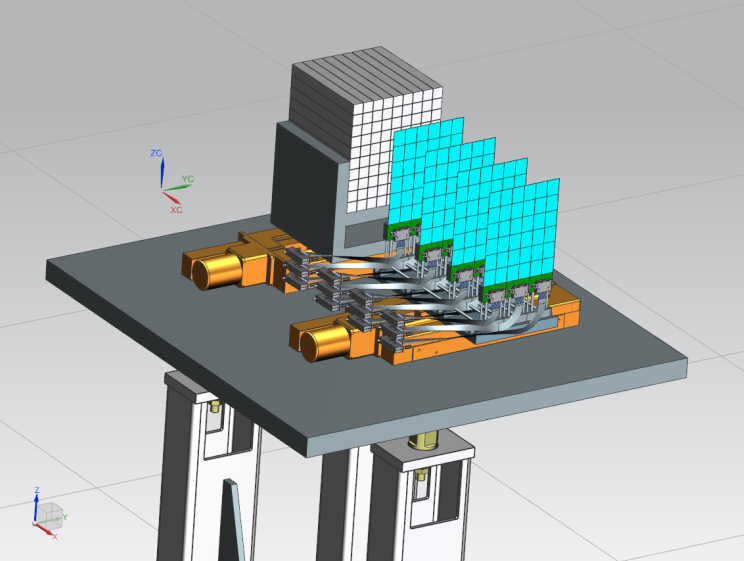
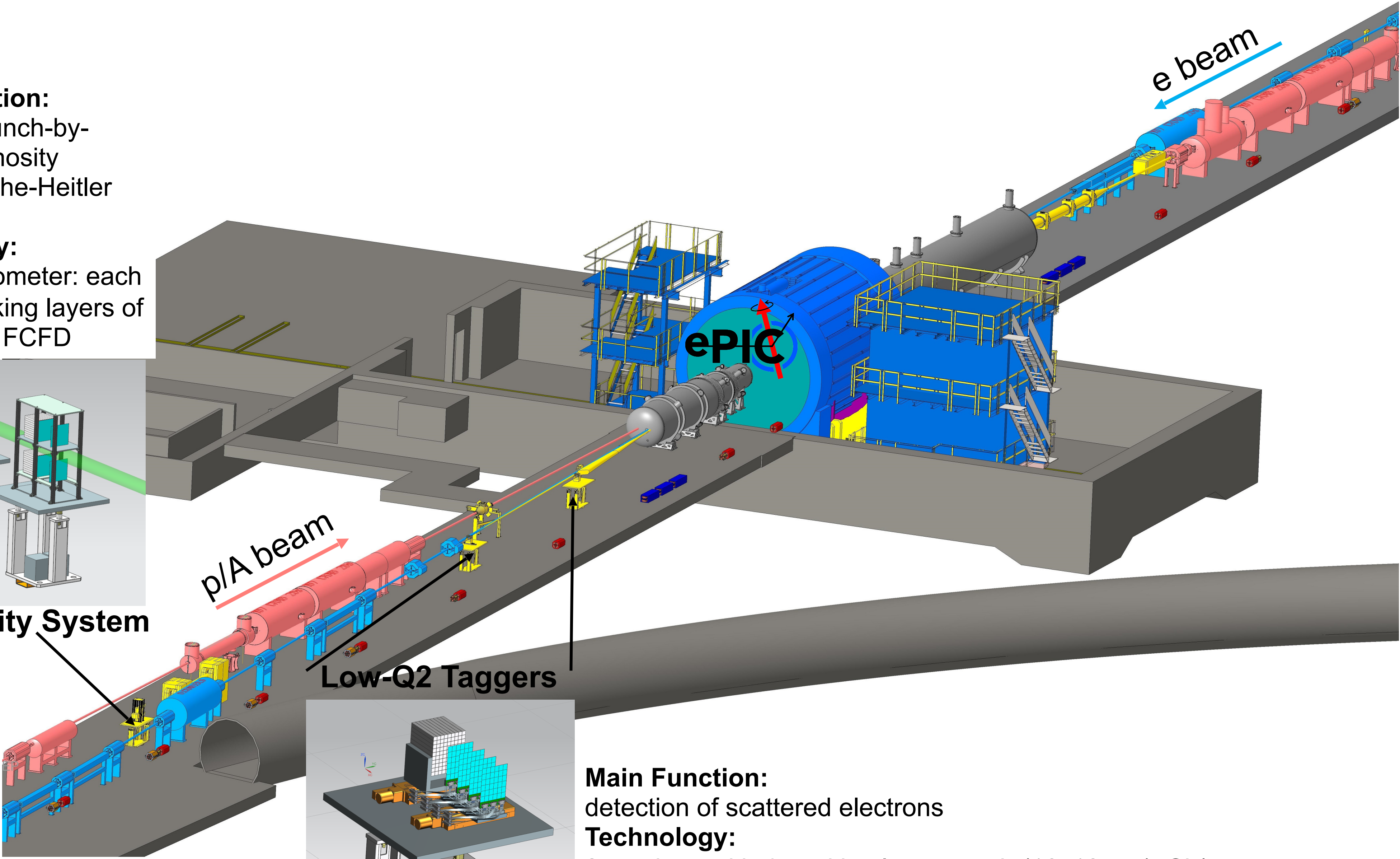

**Main Function:**  
detection of scattered electrons  
**Technology:**  
2 stations with 4 tracking layers each (16x18cm<sup>2</sup>) Si /  
Timepix4

# ePIC Far-Forward/Far-Backward Detectors

**Main Function:**  
measure bunch-by-bunch luminosity through Bethe-Heitler process

**Technology:**  
Pair-spectrometer: each with 2 tracking layers of AC-LGAD / FCFD

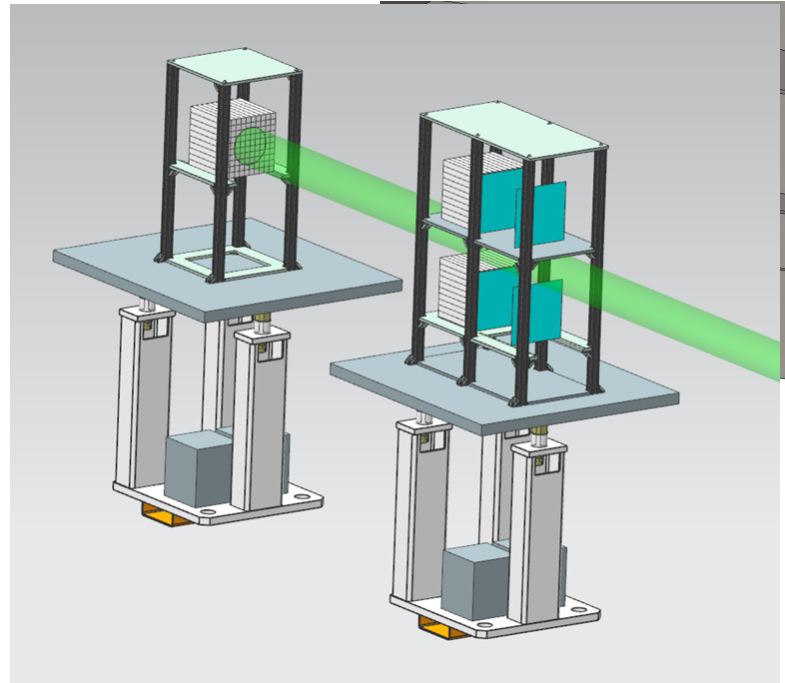

**Luminosity System**

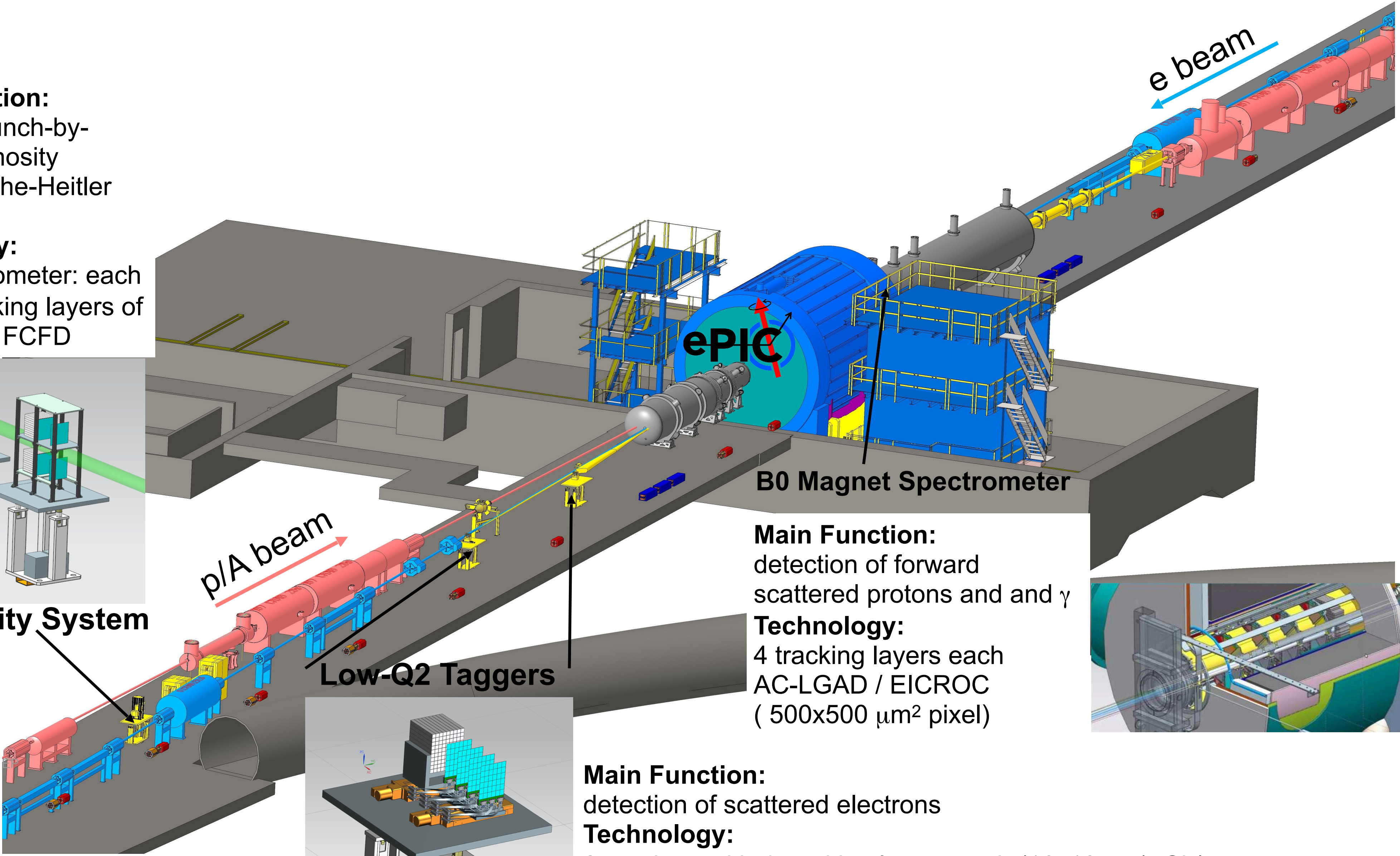

p/A beam

Low-Q2 Taggers

B0 Magnet Spectrometer

**Main Function:**  
detection of forward scattered protons and  $\gamma$

**Technology:**  
4 tracking layers each AC-LGAD / EICROC ( 500x500  $\mu\text{m}^2$  pixel)

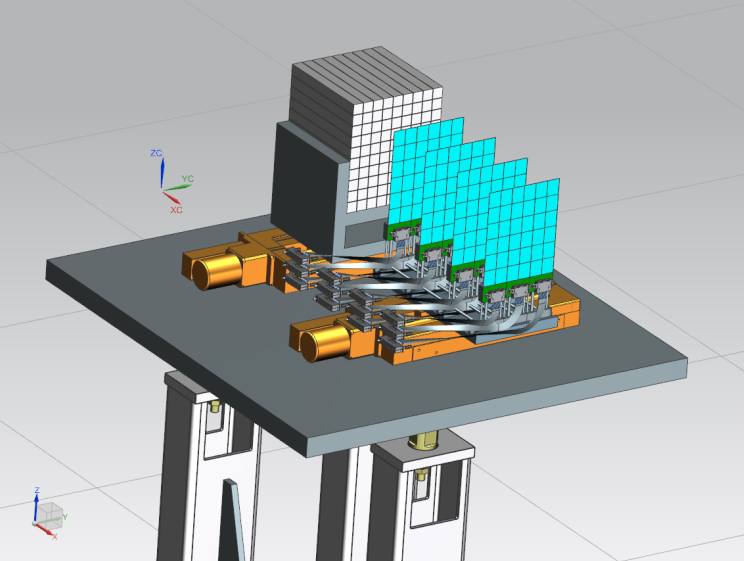
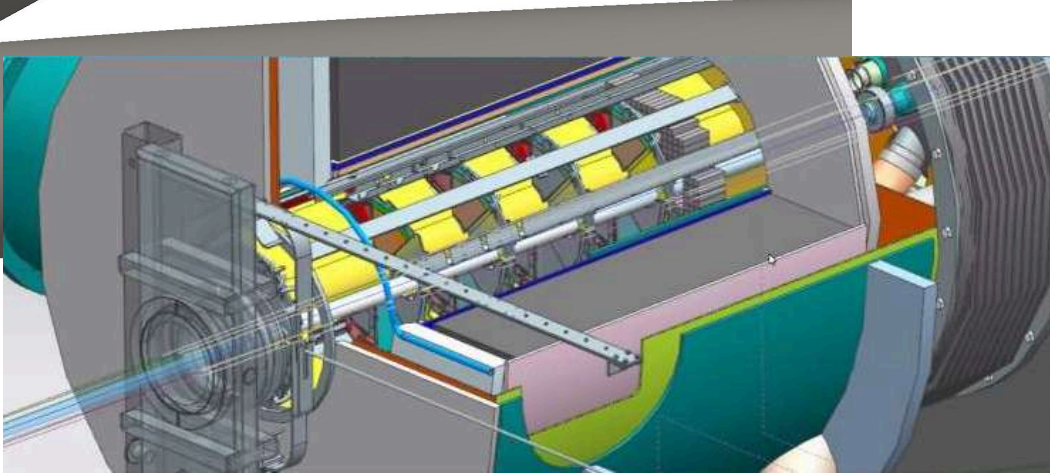

**Main Function:**  
detection of scattered electrons

**Technology:**  
2 stations with 4 tracking layers each (16x18cm<sup>2</sup>) Si / Timepix4

# ePIC Far-Forward/Far-Backward Detectors

**Main Function:**  
measure bunch-by-bunch luminosity through Bethe-Heitler process

**Technology:**  
Pair-spectrometer: each with 2 tracking layers of AC-LGAD / FCFD

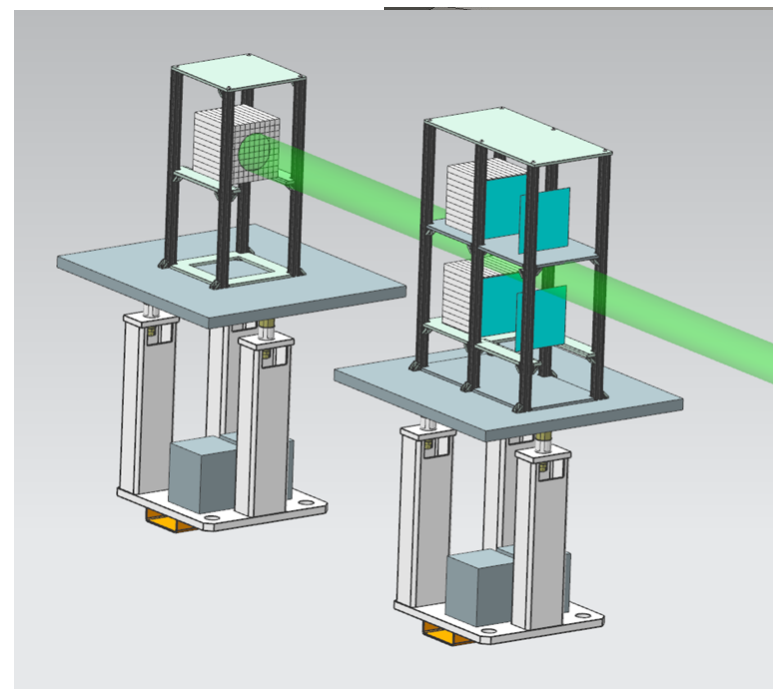

**Luminosity System**

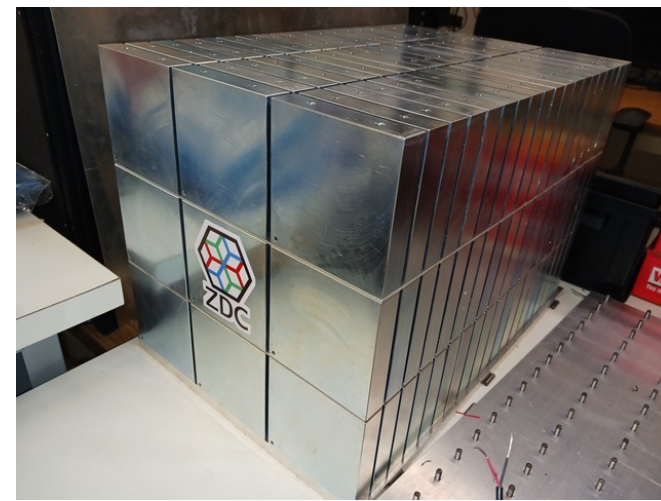

**Main Function:**  
detection of forward scattered neutrons and  $\gamma$

**Technology:**  
EMCAL:  $2 \times 2 \times 20 \text{ cm}^3$   
High res. calorimeter

**Zero Degree Calorimeter**

e beam

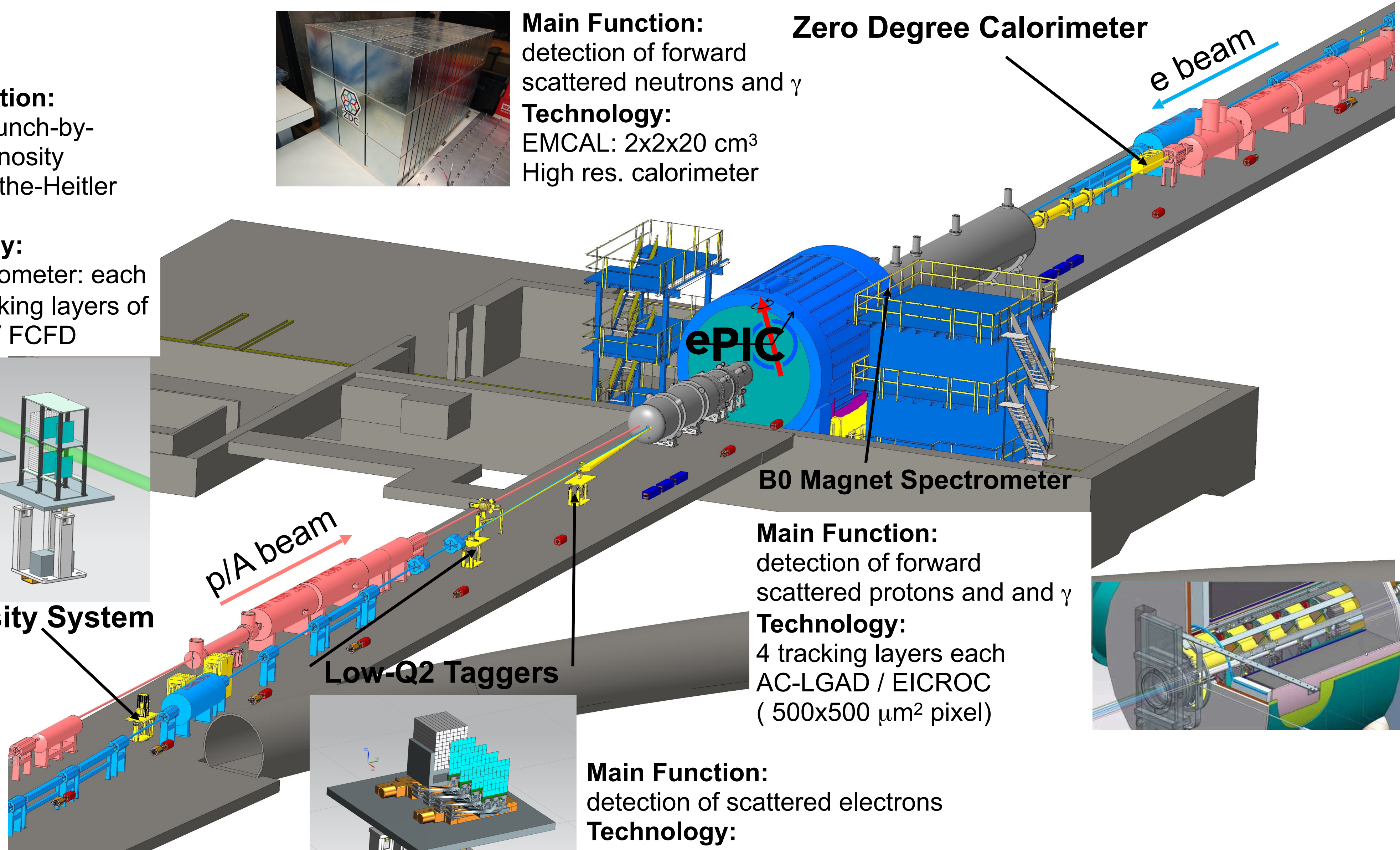

p/A beam

**Low-Q2 Taggers**

ePIC

**B0 Magnet Spectrometer**

**Main Function:**  
detection of forward scattered protons and  $\gamma$

**Technology:**  
4 tracking layers each AC-LGAD / EICROC ( $500 \times 500 \mu\text{m}^2$  pixel)

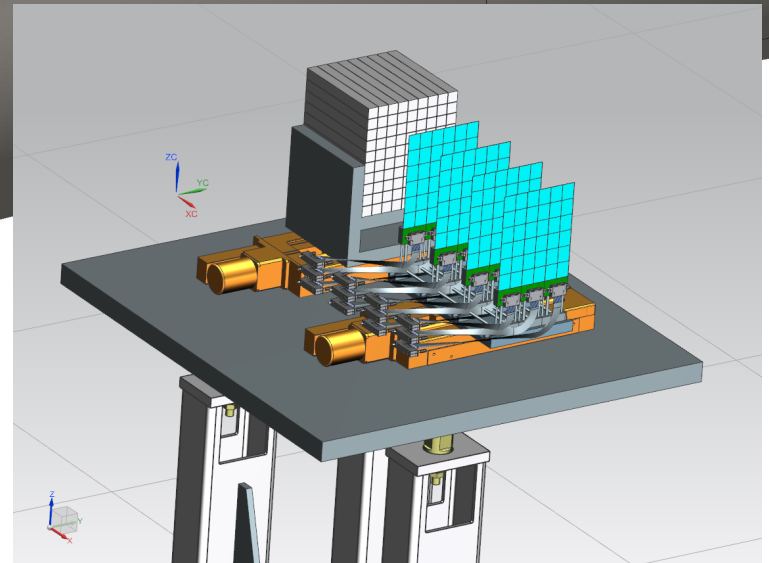
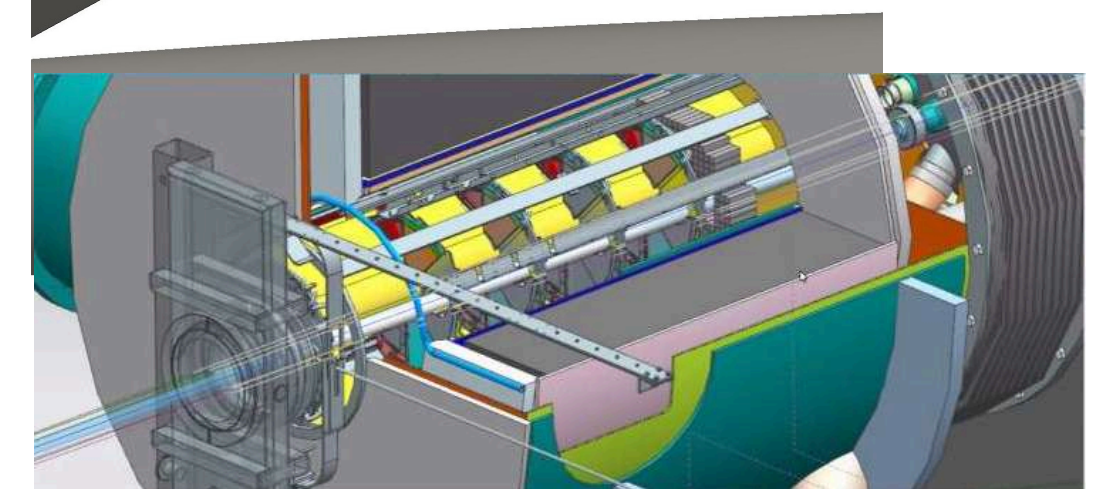

**Main Function:**  
detection of scattered electrons

**Technology:**  
2 stations with 4 tracking layers each ( $16 \times 18 \text{ cm}^2$ ) Si / Timepix4

# ePIC Far-Forward/Far-Backward Detectors

**Main Function:**  
measure bunch-by-bunch luminosity through Bethe-Heitler process

**Technology:**  
Pair-spectrometer: each with 2 tracking layers of AC-LGAD / FCFD

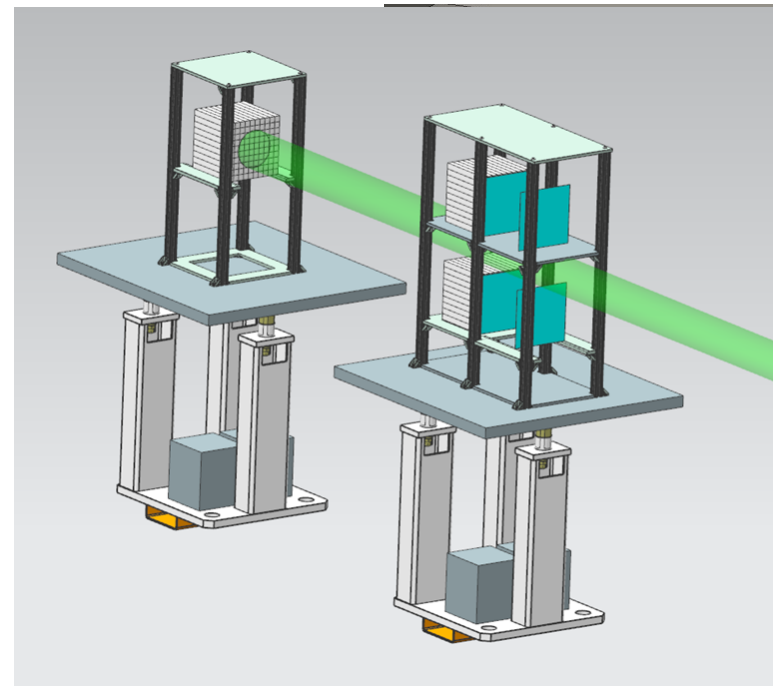

**Luminosity System**

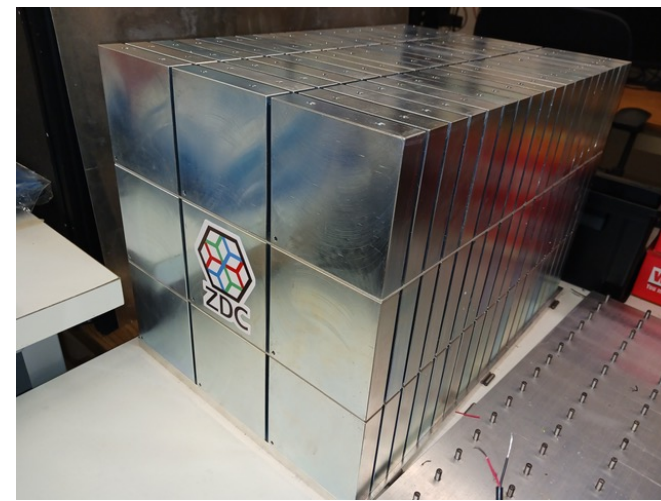

**Main Function:**  
detection of forward scattered neutrons and  $\gamma$

**Technology:**  
EMCAL:  $2 \times 2 \times 20 \text{ cm}^3$   
High res. calorimeter

**Zero Degree Calorimeter**

e beam

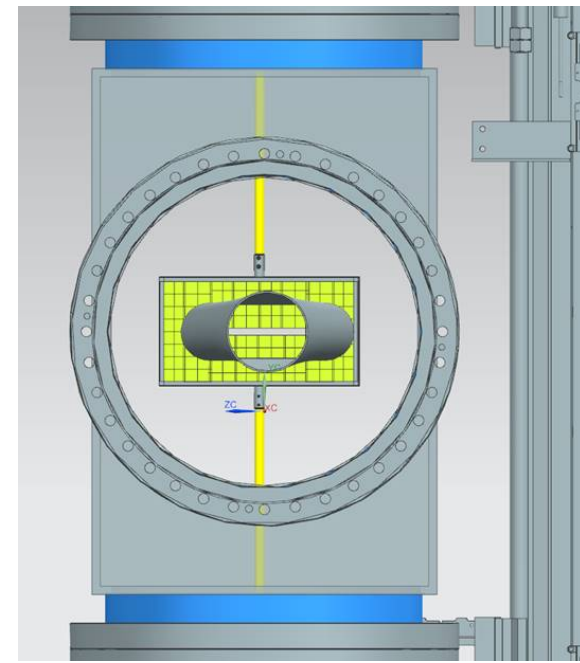

**Roman Pots and Off-Momentum Detectors**

**Main Function:**  
detection of forward scattered protons and nuclei

**Technology:**  
2 stations with 2 tracking layers each AC-LGAD / EICROC ( $500 \times 500 \mu\text{m}^2$  pixel)

**B0 Magnet Spectrometer**

**Main Function:**  
detection of forward scattered protons and  $\gamma$

**Technology:**  
4 tracking layers each AC-LGAD / EICROC ( $500 \times 500 \mu\text{m}^2$  pixel)

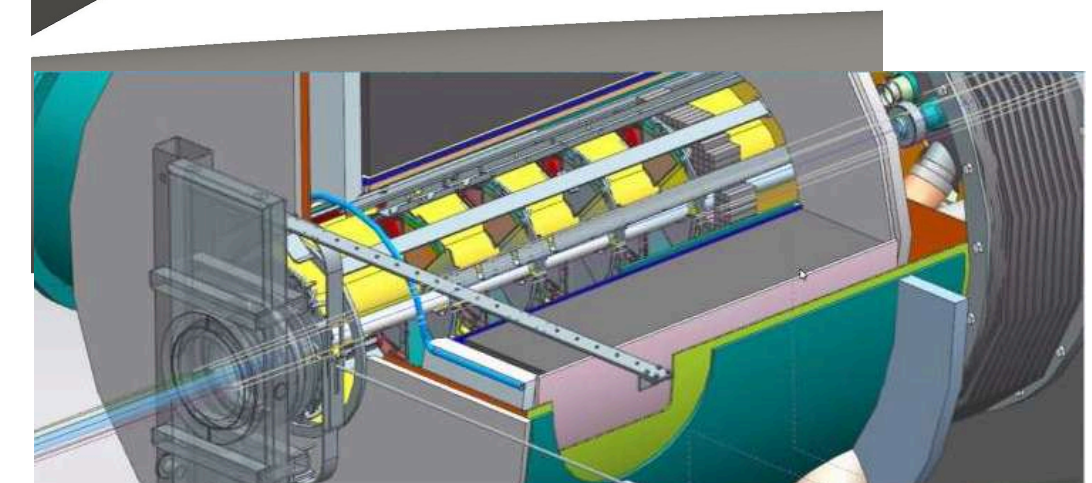

p/A beam

**Low-Q2 Taggers**

**Main Function:**  
detection of scattered electrons

**Technology:**  
2 stations with 4 tracking layers each ( $16 \times 18 \text{ cm}^2$ ) Si / Timepix4

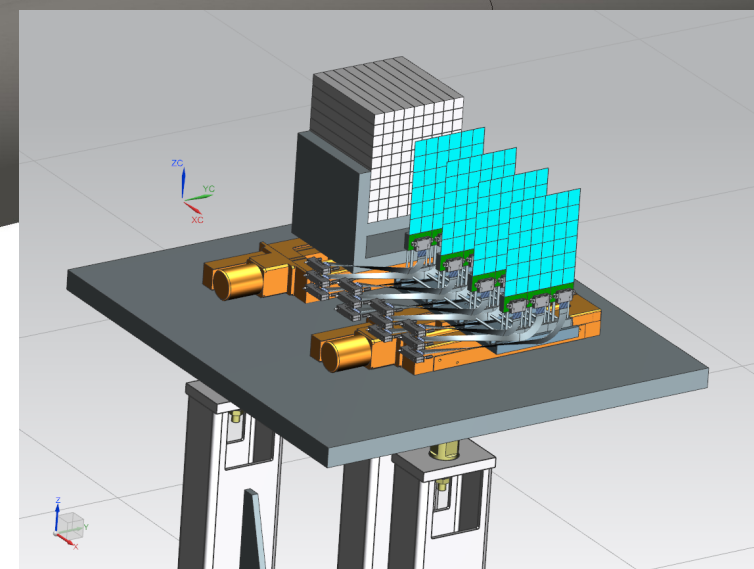

# Streaming DAQ

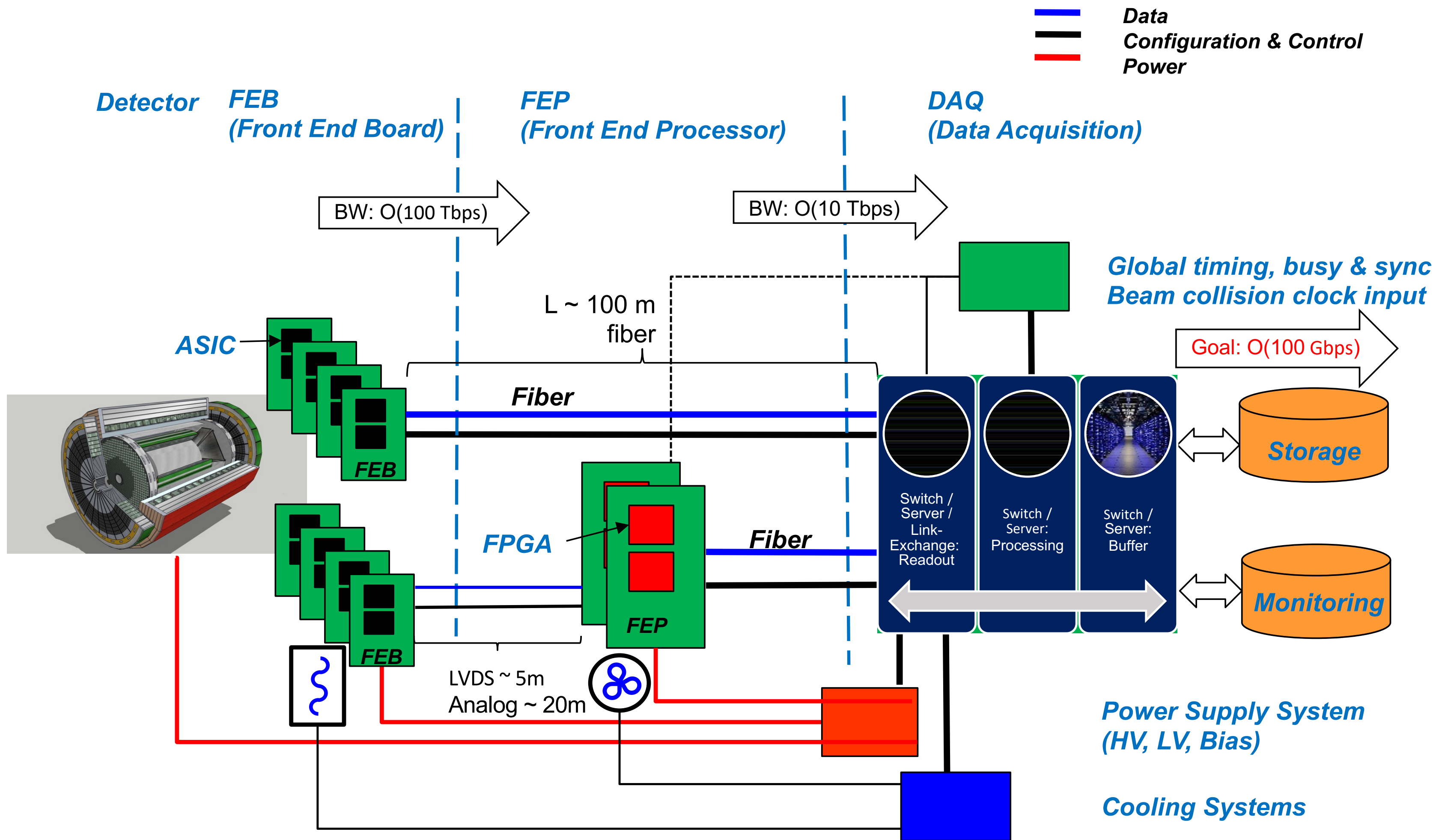

- No external trigger
- All collision data digitized but aggressively zero suppressed at FEB
- Low / zero deadtime
- Event selection can be based upon full data from all detectors (in real time, or later)
- Collision data flow is independent and unidirectional  $\Rightarrow$  no global latency requirements
- Avoiding hardware trigger avoids complex custom hardware and firmware
- Data volume is reduced as much as possible at each stage

Benefits from low multiplicity/occupancy even in eA.  
 Background impact under study.  
 At full  $\mathcal{L} \Rightarrow \sim 0.5 \text{ MHz}$  interaction rate.

# Integration

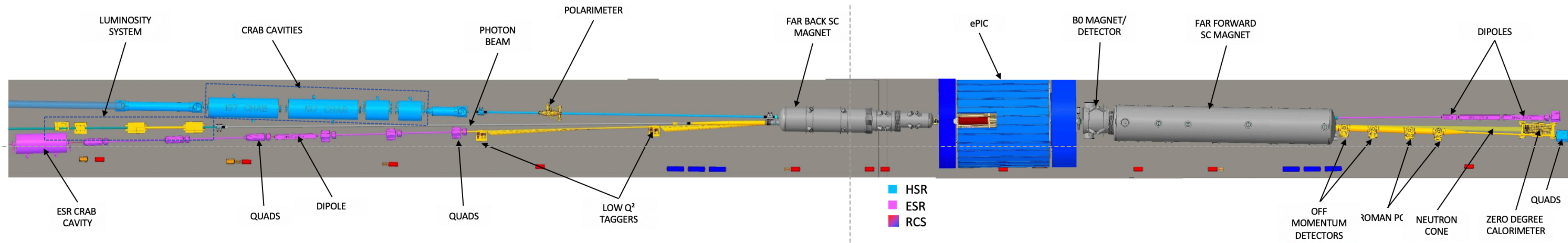

## Integration Challenges

- All subdetectors and services into the main detector volume
- Installation of detector and accelerator components
- Integrate main detector and ancillary detectors into the IR and electron and hadron beam lattice
- Moving ePIC of hall for maintenance critical
- RCS beam line is limiting lateral dimension

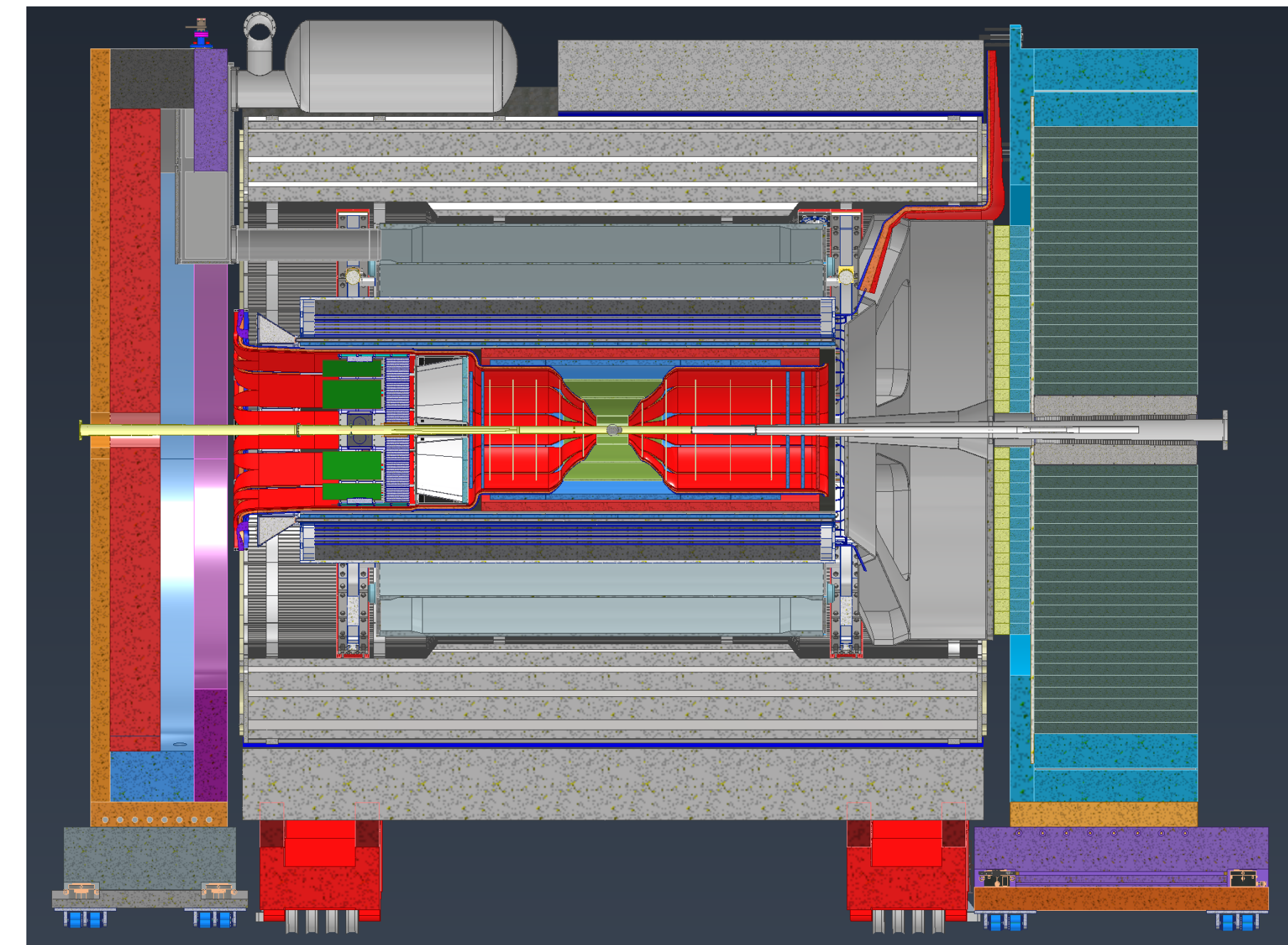



# Closing Comments

EIC will provide answers to profound questions in QCD

- **ep**: Precision studies of structure functions, TMDs, and GPDs will lead to the **most comprehensive picture of the nucleon ever: its flavor, spin, and spatial structure**
- **eA**: Unprecedented study of matter in a new regime of QCD. New capabilities open a new frontier to **study the saturation region**, measure the gluonic structure of nuclei, and investigate **color propagation**, and fragmentation using the nucleus as analyzer.

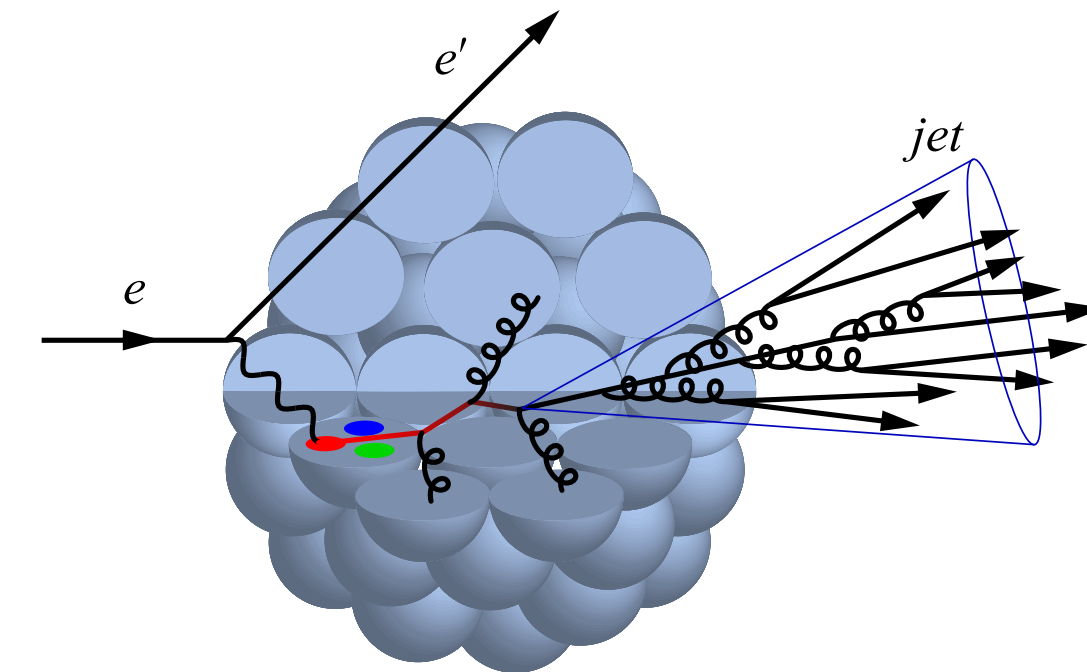
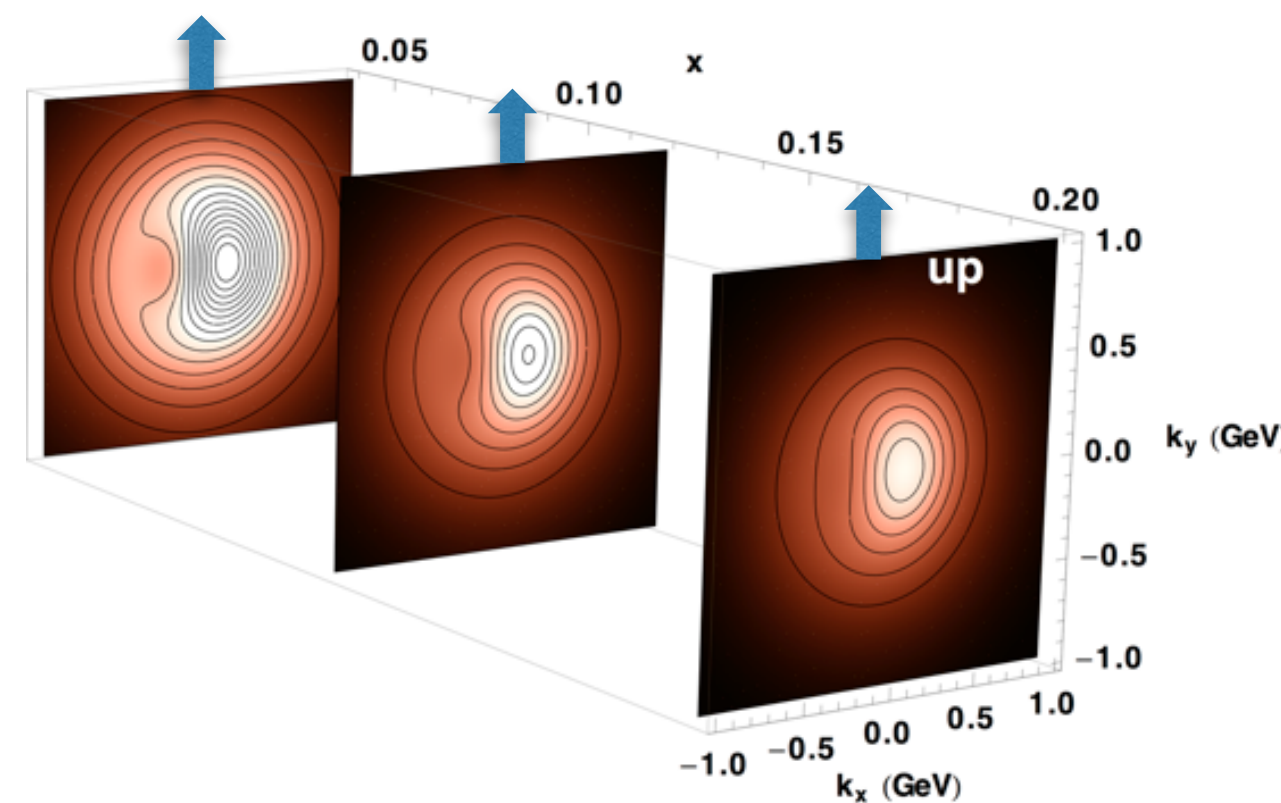
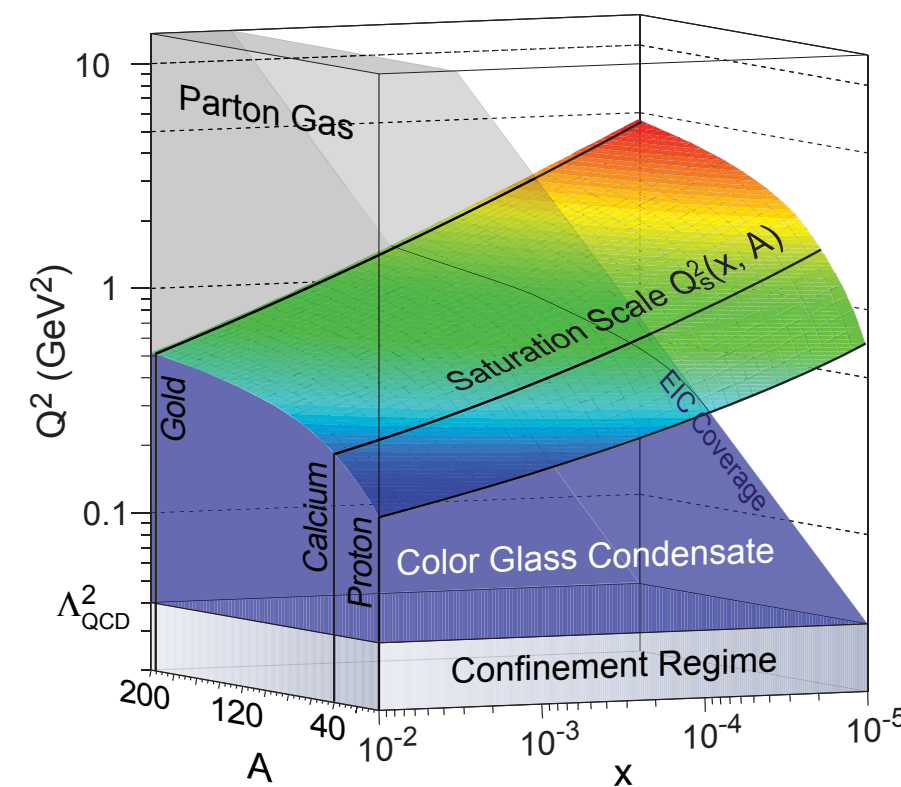

**There is precedent for surprises in nature, provided you look**

Event #4

0.0 ns

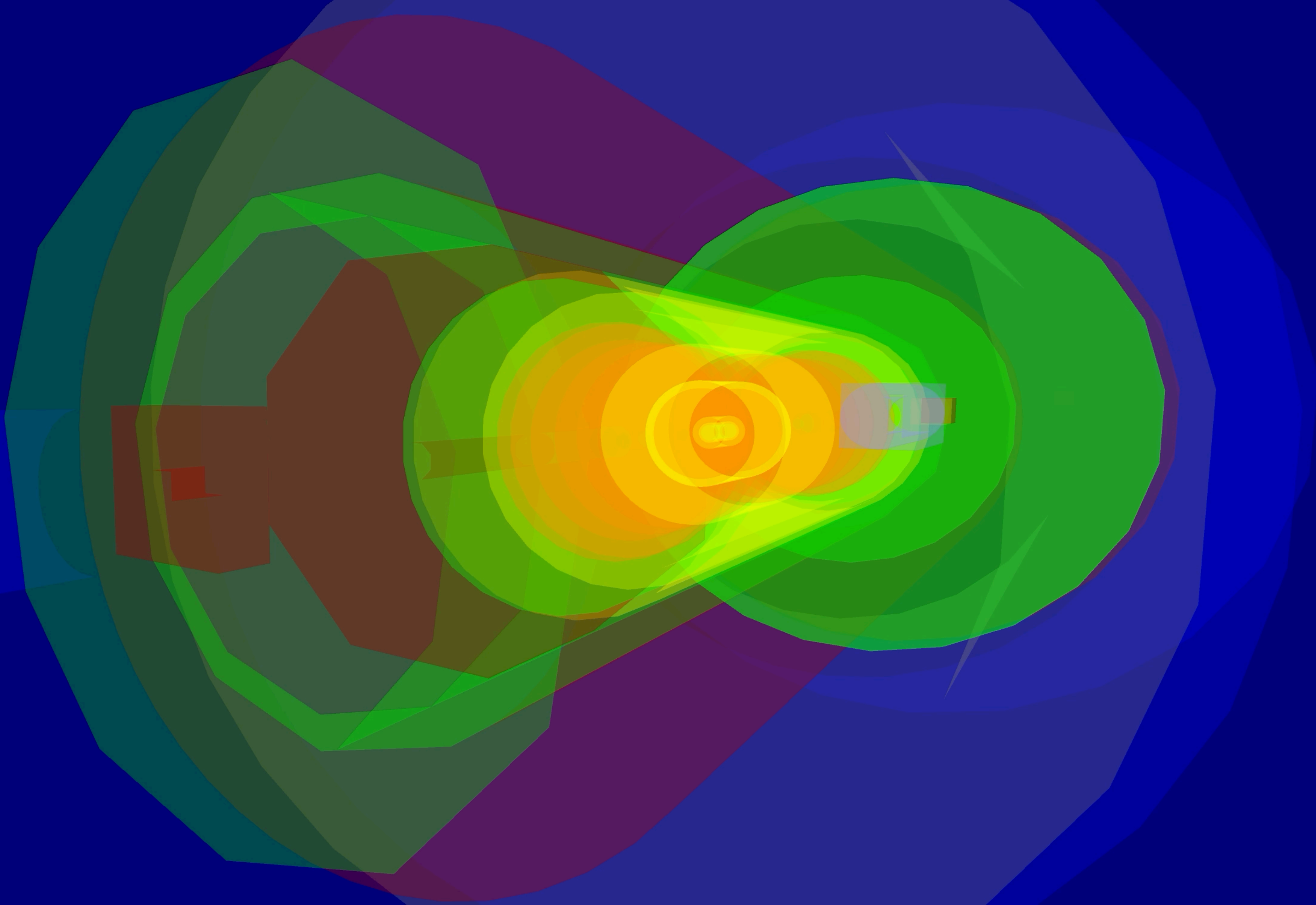

Event #4

0.0 ns

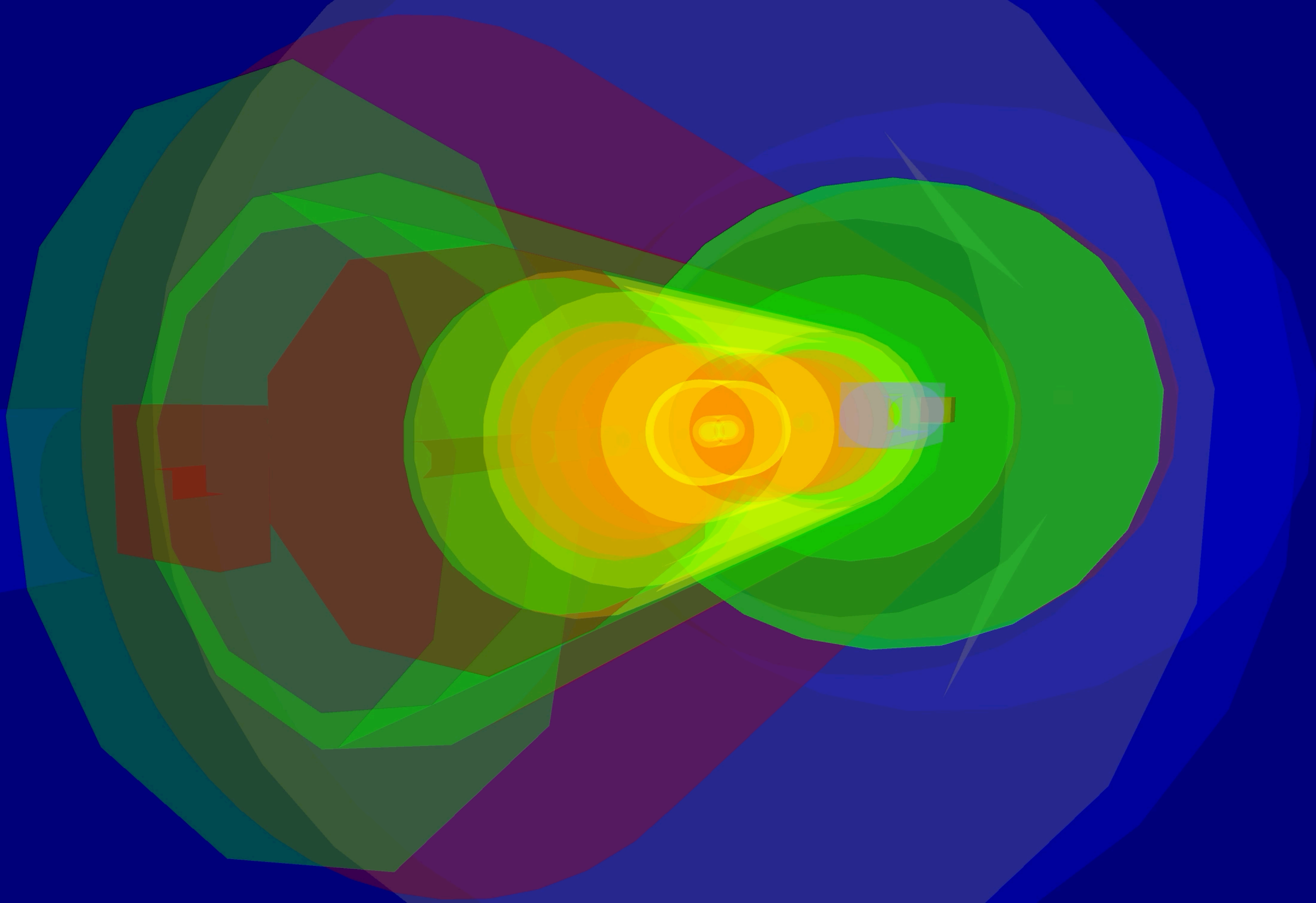

Event #4

0.0 ns

