

Figures courtesy of BNL

ePIC at EIC: A Detector Designed for Precision QCD

Sylvester Joosten
Argonne National Laboratory

POETIC 2025
Monday, February 24, 2025



This work is supported by the U.S. Department of Energy, Office of Science, Office of Nuclear Physics, under contract DE-AC02-06CH11357.



Nuclear Matter is Dynamical in Nature

An EIC can uniquely address three profound questions about nucleons and how they are assembled to form the nuclei of atoms

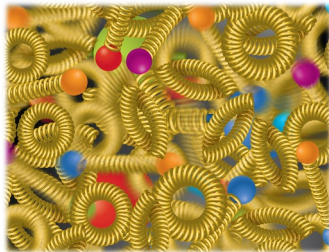

- How does the mass of the nucleon arise?
- How does the spin of the nucleon arise?
- What are the emergent properties of dense systems of gluons?

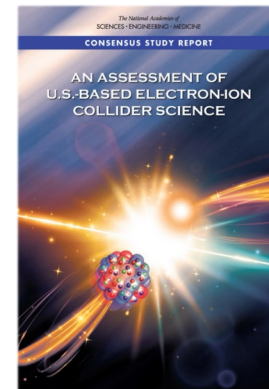

- Most of the visible matter in the universe is made of protons and neutrons
- Basic properties, such as proton mass and spin, emerge from the complex dynamical structure of QCD itself
- With the EIC, we will image quarks and gluons and their interactions to understand matter at its most fundamental level

EIC Science is Impactful!

We will map the quark and gluon dynamics that generate over 99% of the mass of the visible universe!

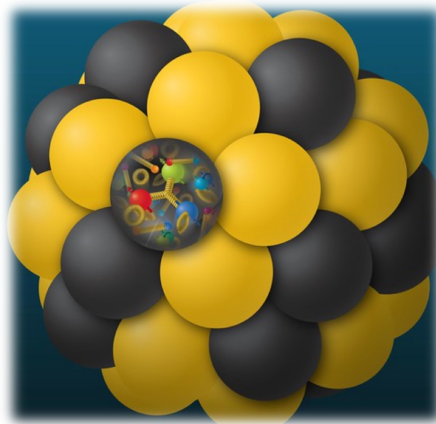
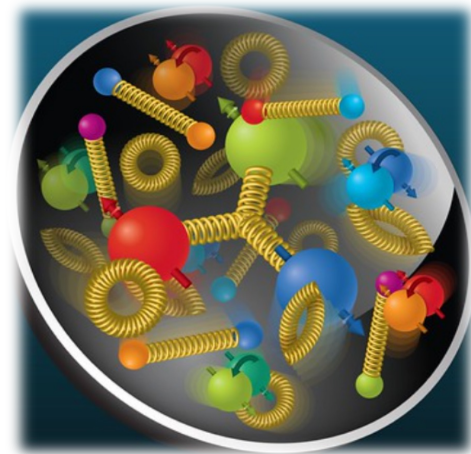

EIC will provide transformational insights into the heart of nucleons and nuclei

We are driving innovation to build a state-of-the-art experiment, leveraging breakthroughs in accelerator, detector, readout, and computing technologies

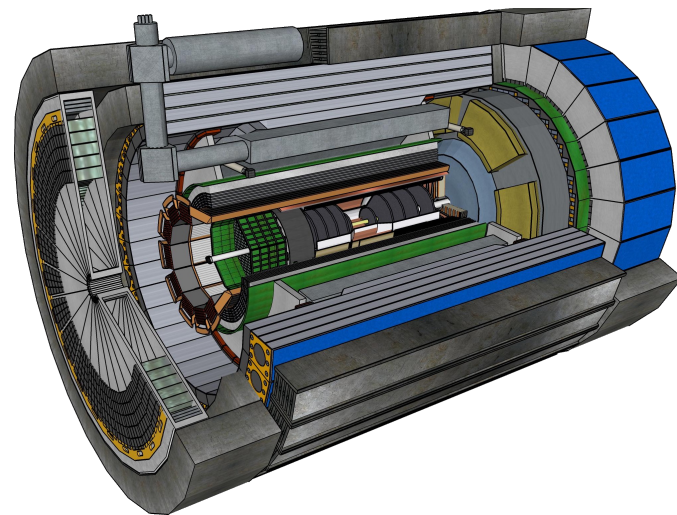

The Electron-Ion Collider

A Frontier Accelerator in the USA

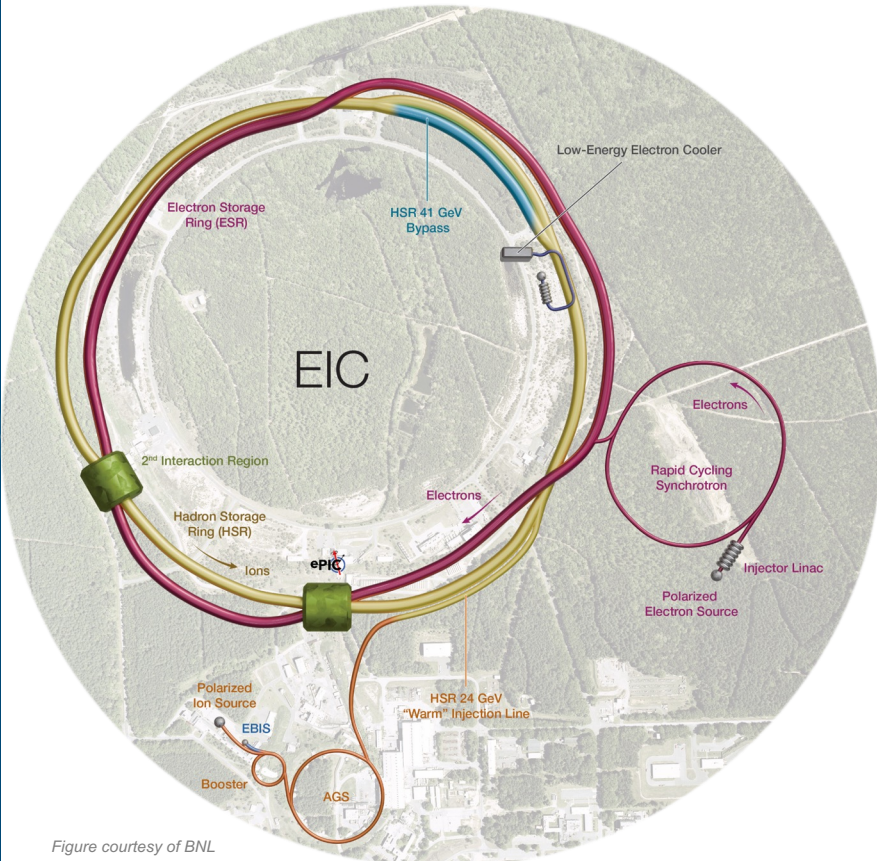

World's first collider of:

- Polarized electrons and polarized protons
- Polarized electrons and light ions (d, ^3He)
- Electrons and heavy ions (up to Uranium)

A versatile machine:

- Beam polarizations up to 70%,
- Versatile range of beam species
- Versatile range of center of mass energies, $E_{\text{cm}} = 29 - 140 \text{ GeV}$

A high luminosity machine

- up to $\mathcal{L} = 10^{34} \text{ cm}^{-2} \text{ s}^{-1}$
- At peak luminosity, the e-p signal event rate will be about 500 kHz

Figure courtesy of BNL

The ePIC Experiment

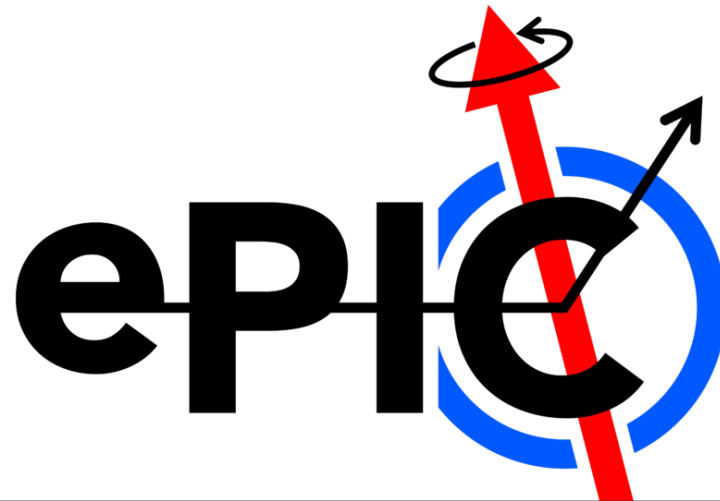

- ePIC is the primary experiment at the EIC
- It is a highly integrated, multi-purpose experiment
- The experiment is being developed by the ePIC collaboration in partnership with the EIC Project
- The collaboration was formed in 2022, and is international in scope

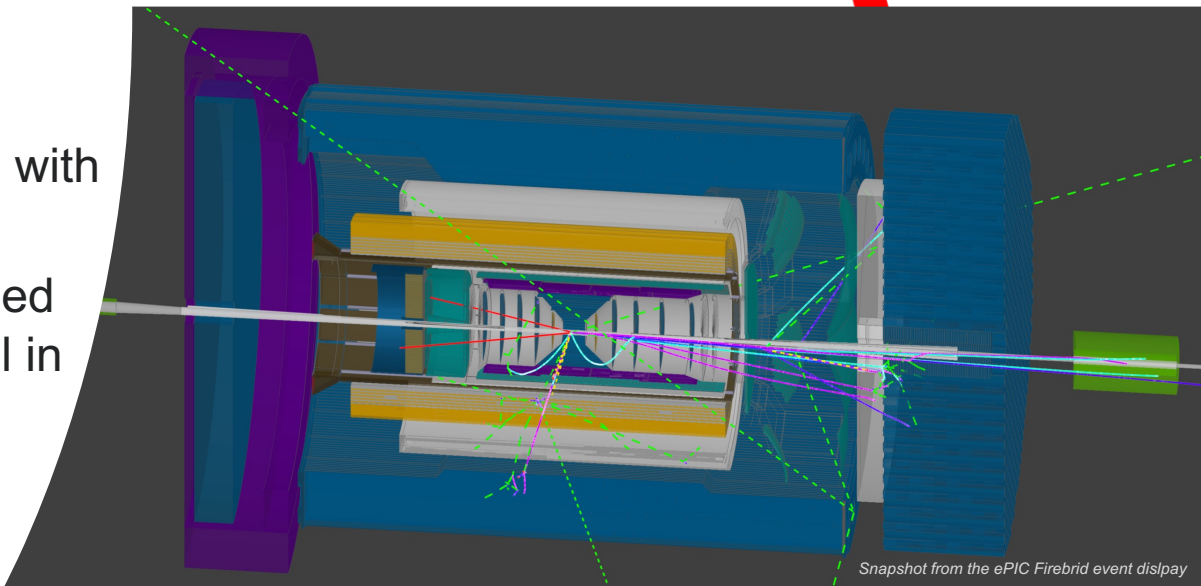

Snapshot from the ePIC Firebird event display

EIC Physics Needs Near-Full Acceptance

Integrated Interaction Region and Detector Design

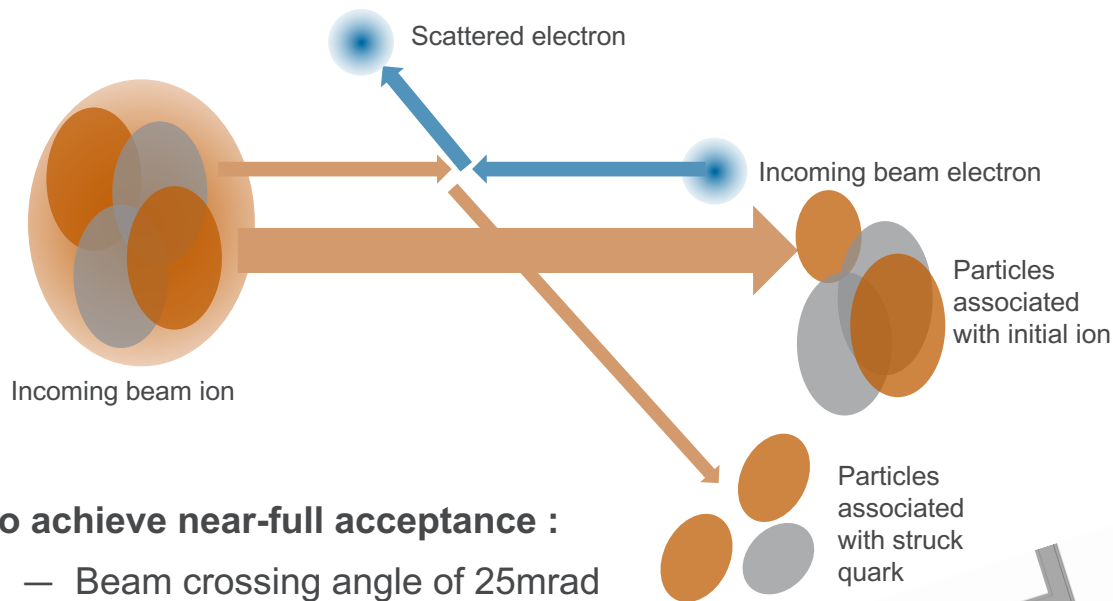

Experimental challenges:

- Beam elements limit forward acceptance.
- Central solenoid not effective for particles with small deflection angles

To achieve near-full acceptance :

- Beam crossing angle of 25mrad creates room for dipoles and ZDC
- Dipoles act as spectrometers while creating space for detectors

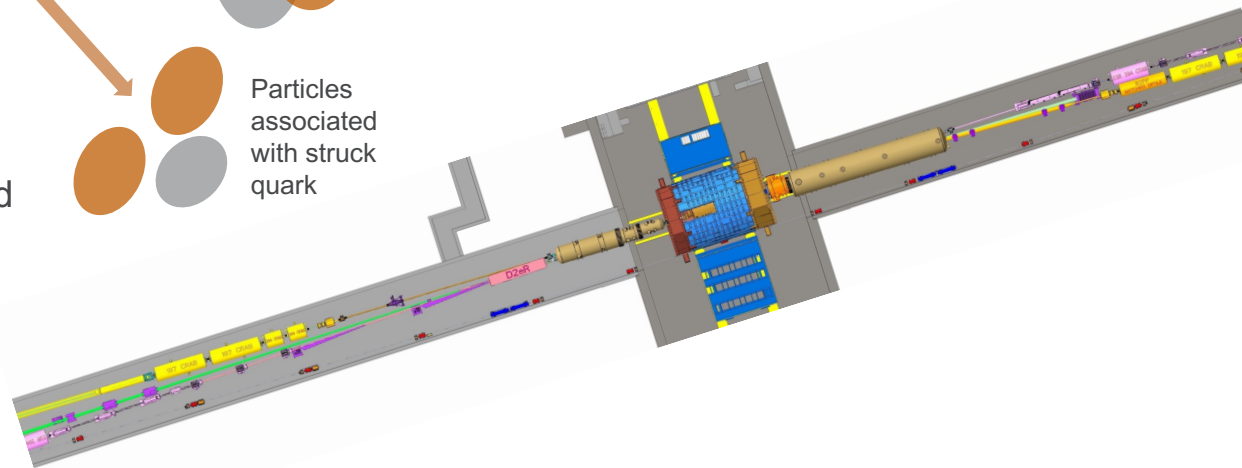

The ePIC detector is ...
90 meter long!

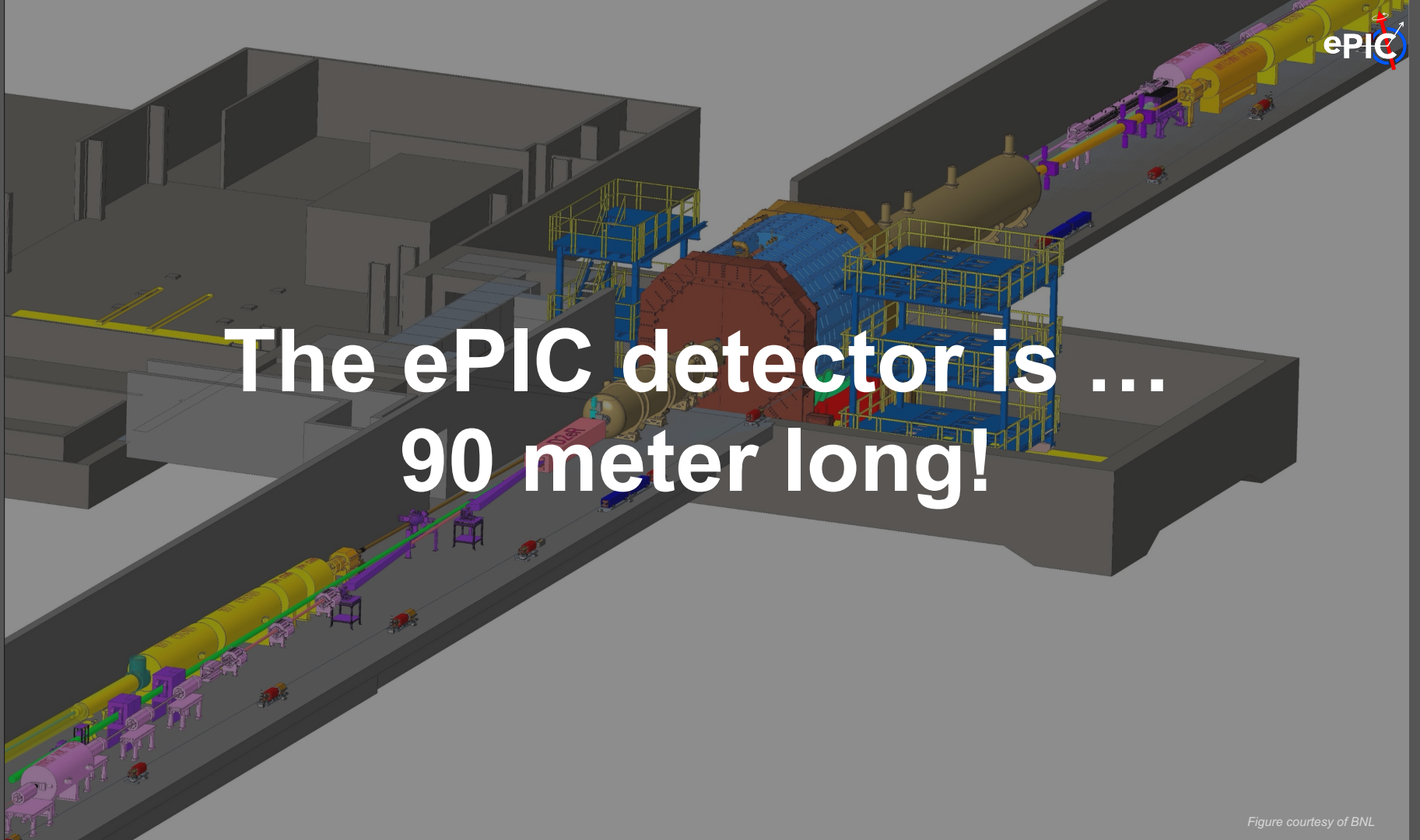

Physics-Driven Detector Design

Inclusive DIS requires fine binning in x_B , Q^2 :

- Large angular coverage for wide phase space reach
- Excellent EM-calorimetry with PID support for e/π separation, and good electron energy resolution
- Fine resolution tracking with low mass

Semi-inclusive DIS requires binning in five or more variables (x_B , Q^2 , z , p_T , ϕ_h , ...):

- Fine p_T resolution
- Extended PID systems for hadron identification
- Hadron calorimetry for jet physics

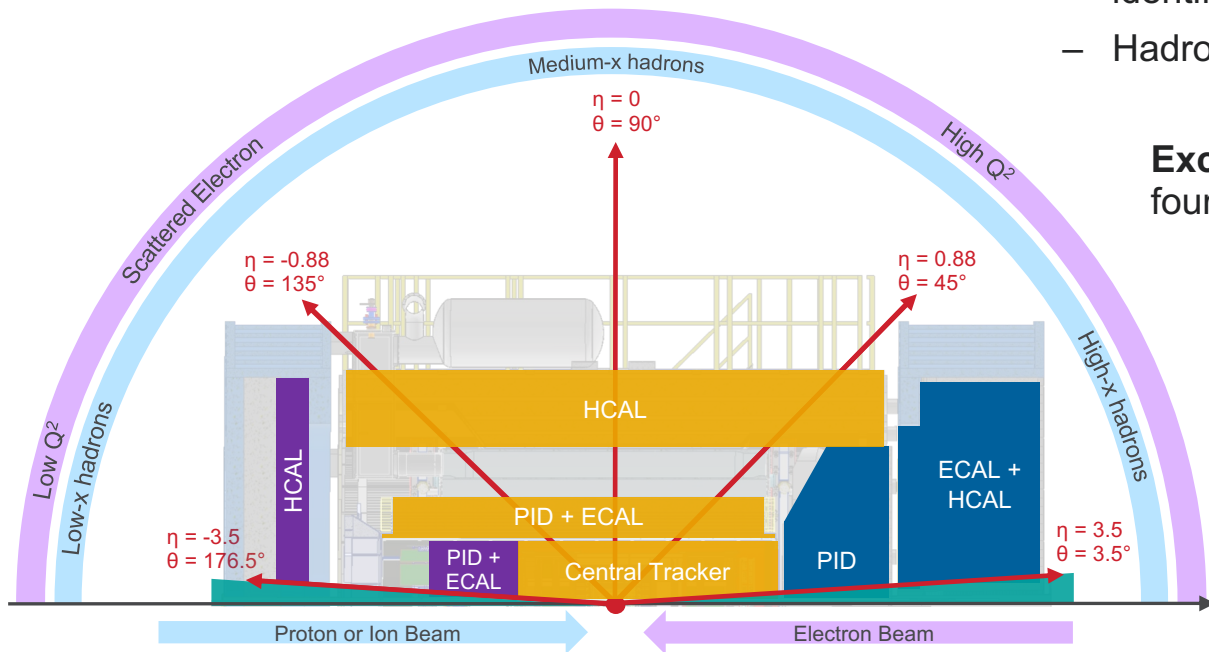

Exclusive processes require binning in four or more variables (x_B , Q^2 , t , ϕ_h , ...):

- Extend acceptance at extremely small scattering angles by far forward detectors
- Fine vertex resolution by tracking
- Highly granular EM-calorimeters to separate γ/π^0

The Central ePIC Detector

Magnet

- New 1.7 T SC solenoid, 2.8 m bore diameter

Tracking

- Si Vertex Tracker MAPS wafer-level stitched sensors (ALICE ITS3)
- Si Tracker MAPS barrel and disks
- Gaseous tracker: MPGDs (μ RWELL, MMG) cylindrical and planar

PID

- high performance DIRC (hpDIRC)
- dual RICH (aerogel + gas) (forward)
- proximity focussing RICH (backward)
- ToF using AC-LGAD (barrel+forward)

EM Calorimetry

- imaging EMCal (barrel)
- W-powder/SciFi (forward)
- PbWO₄ crystals (backward)

Hadron calorimetry

- FeSc (barrel, re-used from sPHENIX)
- Steel/Scint – W/Scint (backward/forward)

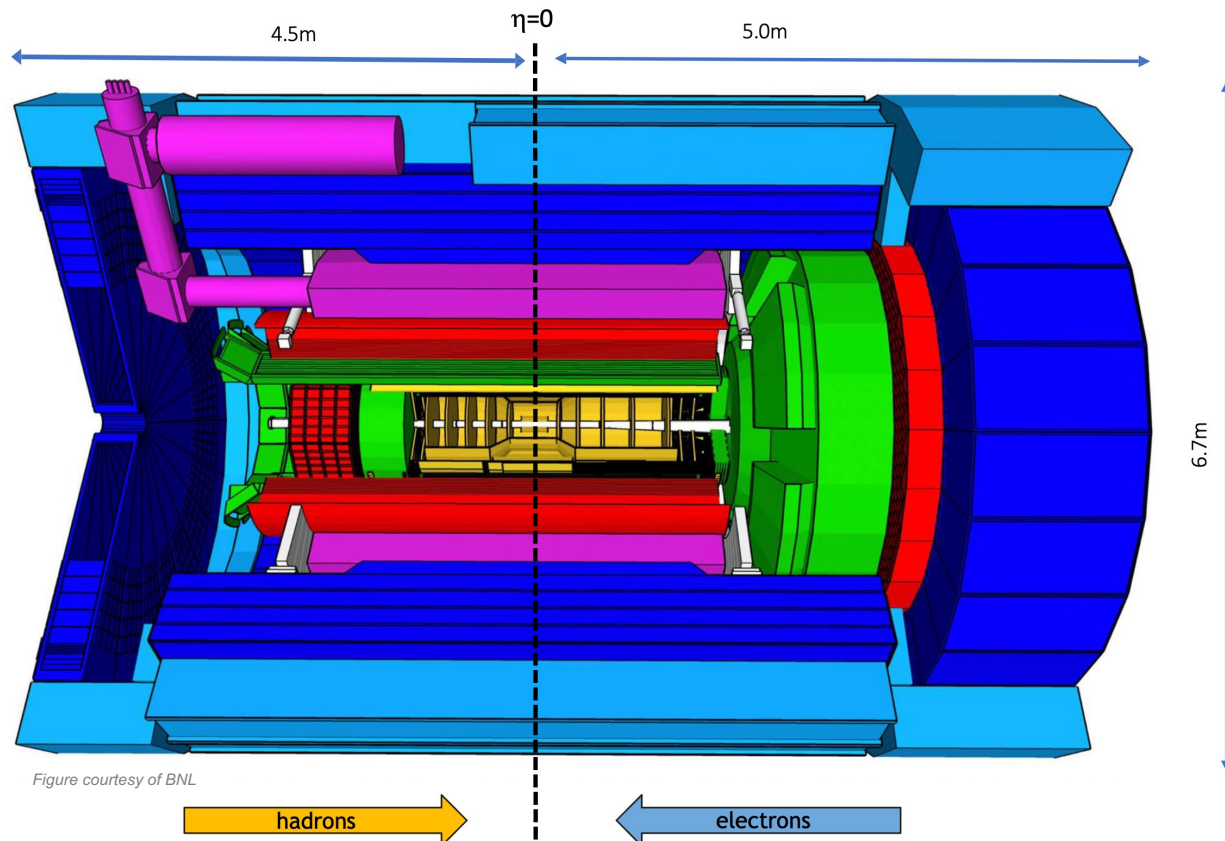

Figure courtesy of BNL

6.7m

hadrons

electrons

The Tracking System

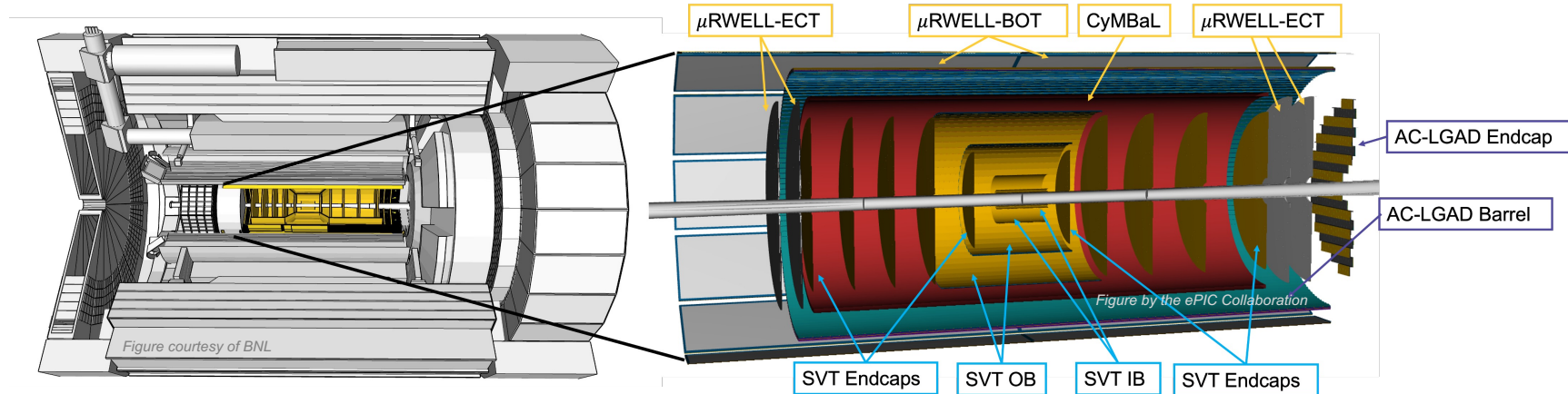

Tracking Requirements:

- High spatial resolution $20\mu\text{m}/\text{pT} \oplus 5\mu\text{m}$
- Excellent momentum resolution $0.05\%\text{pT} \oplus 0.5\%$
- Low material budget
- Good pattern recognition efficiency
- Sufficient time resolution to resolve 10ns bunch crossing
- Good angular resolution for the DIRC

Detector Solutions

- Ultra-low-mass **barrel vertex tracker** using ALICE ITS3 curved MAPS technology, with $20\mu\text{m}$ pixel pitch and $0.05\% X/X_0$
- **Outer barrel and endcap silicon tracker** using new ITS3-based EIC Large Area Sensors (LAS), with $20\mu\text{m}$ pixel pitch and $0.55\% X/X_0$
- **MicroMegas barrel tracker** (CyMBaL) with X/X_0
- **GEM- μ RWell barrel and endcap tracker** with 10ns time resolution, $150\mu\text{m}$ spatial resolution and $1\text{-}2\% X/X_0$

The PID System

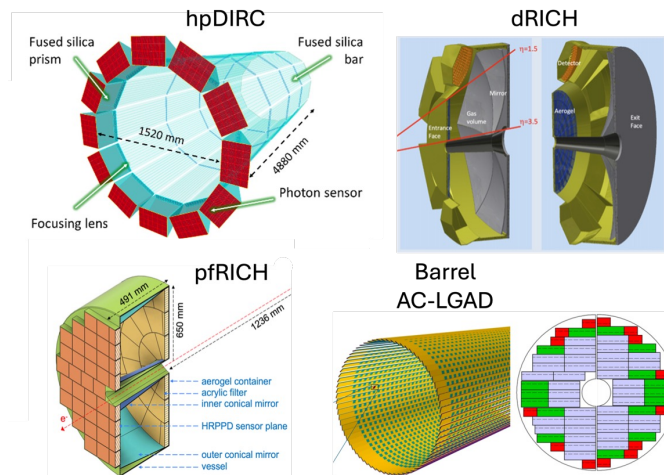
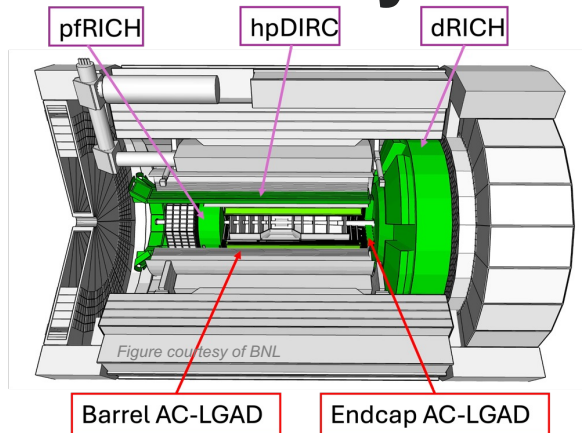

Dual Radiator Ring Imaging Cherenkov (dRICH)

- Aerogel + C_2F_6 gas for high-momentum PID up to 50 GeV/c
- First-ever use of SiPMs in a RICH

Proximity Focusing RICH (pfRICH)

- Aerogel for PID up to 9 GeV/c
- First-ever use HRPPDs as photosensor \rightarrow 30ps time resolution for ToF

High-Performance DIRC Detector (hpDIRC)

- Quartz bar radiator for PID up to 6 GeV/c
- Fully focused design with lens and large expansion volume
- Uses pixelized MCP-PMTs as photosensors

Time-of-Flight Barrel and Forward Endcap (BTOF and FTOF)

- AC-LGAD sensors give 20-35ps time resolution for ToF, for PID up to $p_T < 1.5\text{-}2.5$ GeV/c
- $500\mu\text{m} \times 1$ cm strips for BTOF (1% X/X_0) and $500\mu\text{m}$ pixel pitch for FTOF (2.5% X/X_0)
- Additional accurate space point and timing for tracking
- First-time use of AC-LGAD technology in a collider detector

The Electromagnetic Calorimeter System

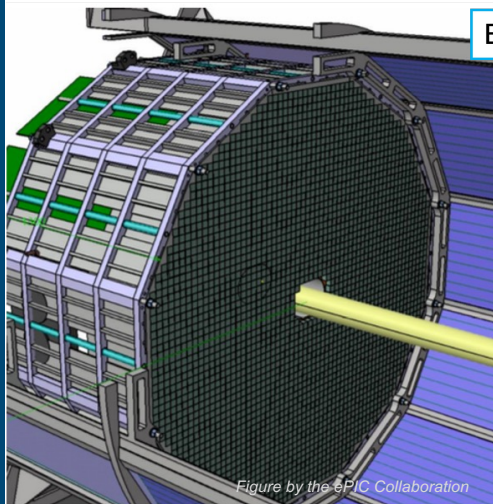

Backward EM Calorimeter

Forward EM Calorimeter

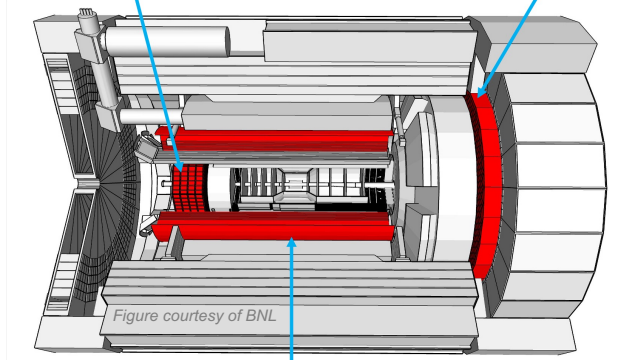

Barrel Imaging Calorimeter

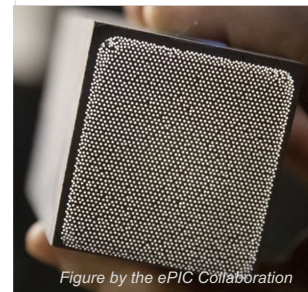

Forward Ecal

- W-powder/SciFi SPACAL design developed through EIC R&D and used in sPHENIX

Backward ECAL (EEEMCAL)

- High-precision $PbWO_4$ crystal calorimeter for precision scattered lepton measurements
- First use of SiPMs in a crystal calorimeter

Barrel Imaging Calorimeter (BIC)

- Hybrid imaging calorimeter: 6 layers of AstroPix sensors interleaved with 5 Pb/ScFi layers, followed by a large section of Pb/ScFi
- Pb/ScFi technology based on the GlueX design, using SiPMs for readout at either end of the barrel
- AstroPix: HV-MAPS sensor with $500\mu m$ pixel pitch and $\sim 3.2 ns$ time resolution developed for the NASA AMEGO-X mission.

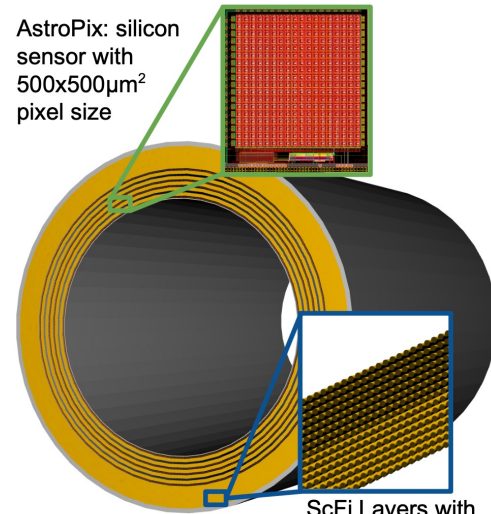

Figure by the ePIC Collaboration

Zooming In: The Barrel Imaging Calorimeter

High-performance sampling calorimeter with cost-effective Si sensors for shower profiling

Electromagnetic calorimetry in the barrel is difficult:

- Prime detector for **electron-pion separation**
- Need pion suppression up to 10^4 for inclusive physics
- Need **good photon resolution and granularity** to reject π^0
- Need **large dynamic range** from 100 MeV/c to well over 10 GeV/c while being sensitive to MIPs
- **Compact** – needs to fit in limited space inside of solenoid

The Barrel Imaging Calorimeter (BIC)

- The BIC is a novel imaging calorimeter designed to meet the stringent performance requirements essential for EIC science
- Combines mature, state-of-the-art Pb/SciFi sampling calorimetry with six layers of modern, ultra-low-power HV-MAPS AstroPix sensors
- The BIC will be one of the largest silicon detectors ever built, featuring over 100 m² of AstroPix sensors and marking the first large-scale deployment of HV-MAPS sensors for particle detection

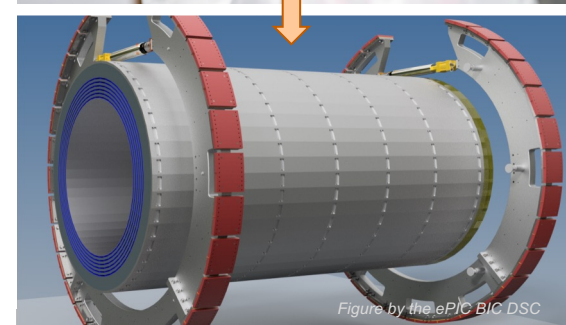
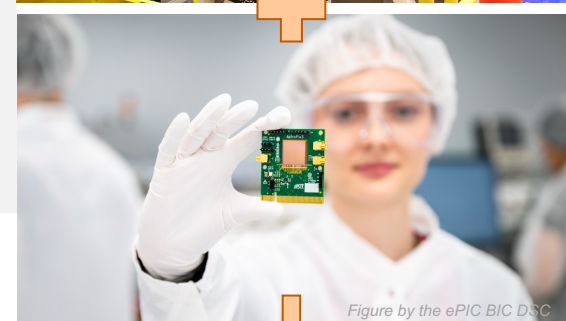

The Hadronic Calorimeter System

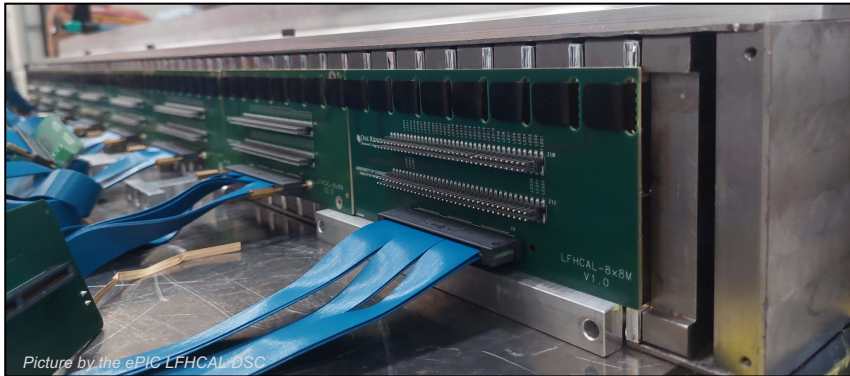

Forward HCAL (LFHCAL)

- Longitudinally segmented steel + scintillator SiPM-on-tile
- High-resolution insert next to beam pipe
- Optimized for particle-flow measurements, first full-size CALICE-like calorimeter in a collider experiment

Barrel HCAL

- Steel + scintillator design, re-use from sPHENIX

Backward HCAL

- Similar construction as LFHCAL, functions as tail catcher for EMCAL to improve jet energy reconstruction

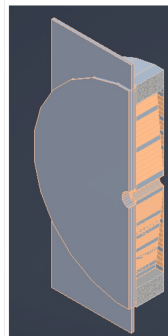
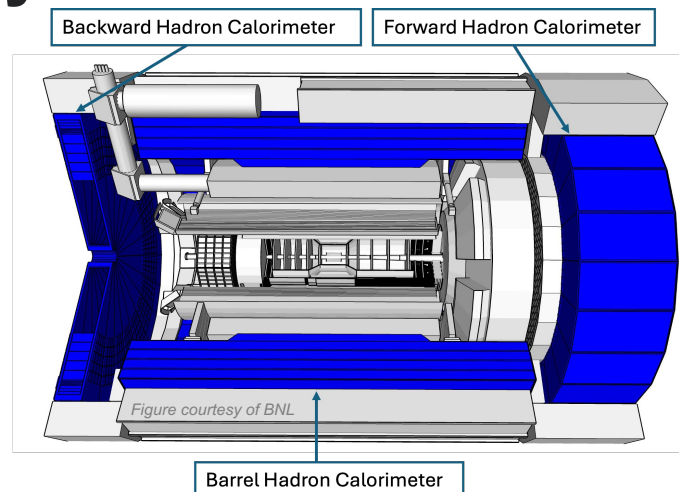

Backward
Hadron Calorimeter



Barrel Hadron Calorimeter

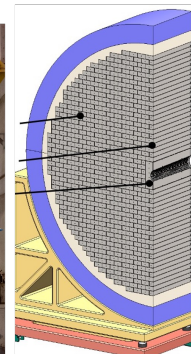

Forward
Hadron Calorimeter

Figures by the ePIC Collaboration

The Far-Forward/Far-Backward System

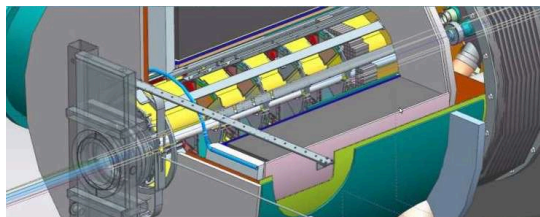

B0 Magnet Spectrometer

- detection of forward scattered protons and γ
- 4 tracking layers each of AC-LGAD / EICROC ($500 \times 500 \mu\text{m}^2$ pixel) – Synergy with forward ToF
- EMCAL: $2 \times 2 \times 20 \text{ cm}^3$ PbWO₄ calorimeter – Synergy with backward ECal

Luminosity System

- Measure bunch-by-bunch luminosity through Bethe-Heitler process
- Pair-spectrometer: each with 2 tracking layers of AC-LGAD / FCFD – Synergy with Barrel-ToF
- Calorimeter: Tungsten-powder + SciFi SPACAL – Synergy with forward ECal

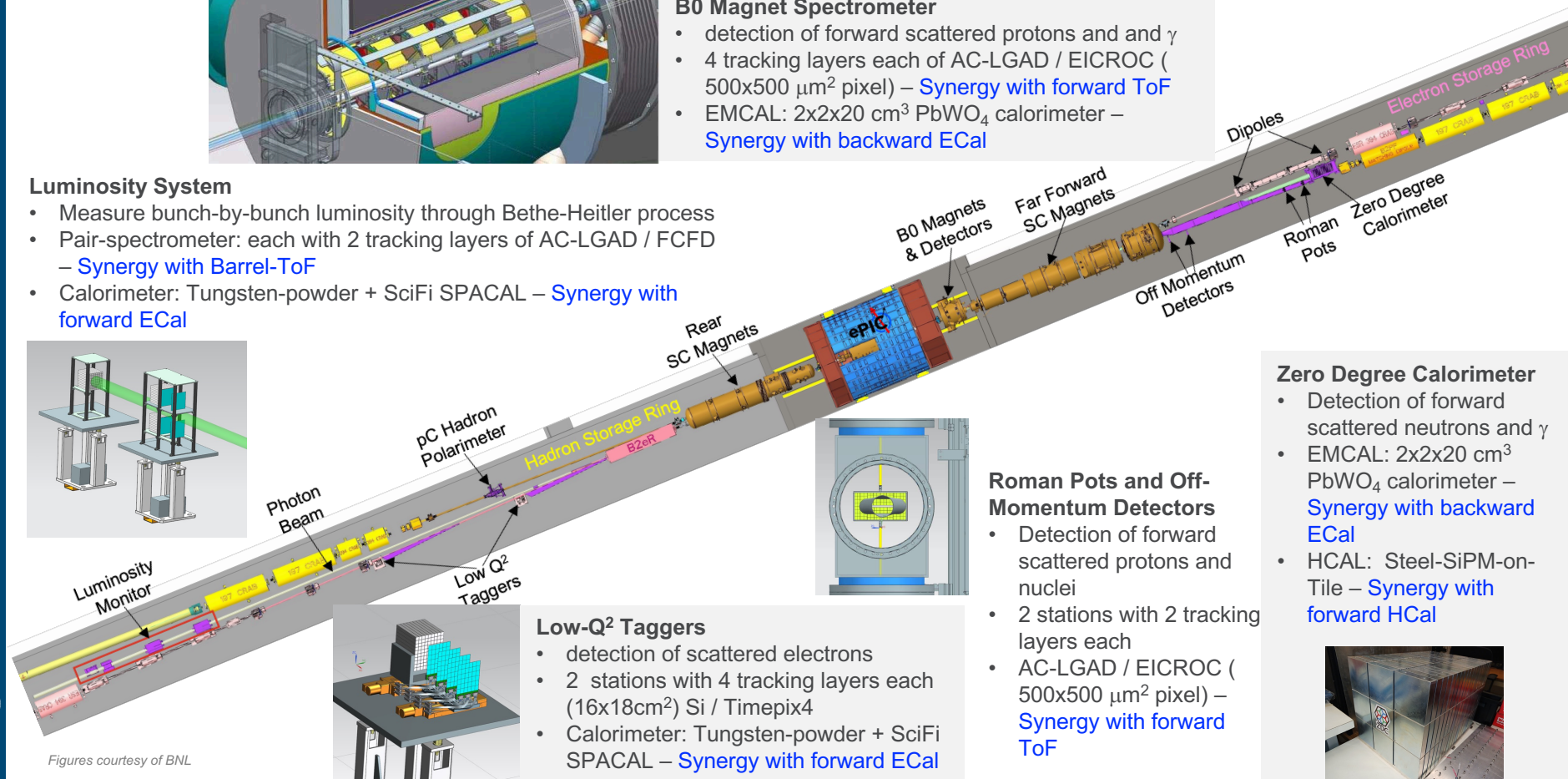
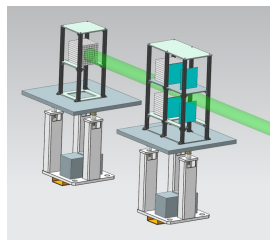

Low-Q² Taggers

- detection of scattered electrons
- 2 stations with 4 tracking layers each ($16 \times 18 \text{ cm}^2$) Si / Timepix4
- Calorimeter: Tungsten-powder + SciFi SPACAL – Synergy with forward ECal

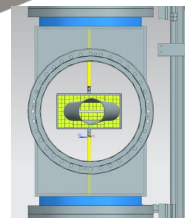
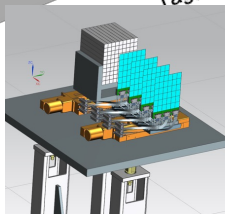

Roman Pots and Off-Momentum Detectors

- Detection of forward scattered protons and nuclei
- 2 stations with 2 tracking layers each
- AC-LGAD / EICROC ($500 \times 500 \mu\text{m}^2$ pixel) – Synergy with forward ToF

Zero Degree Calorimeter

- Detection of forward scattered neutrons and γ
- EMCAL: $2 \times 2 \times 20 \text{ cm}^3$ PbWO₄ calorimeter – Synergy with backward ECal
- HCAL: Steel-SiPM-on-Tile – Synergy with forward HCal



901 collaborators from 178 institutions from 25 countries

ePIC – A Large Collaboration!

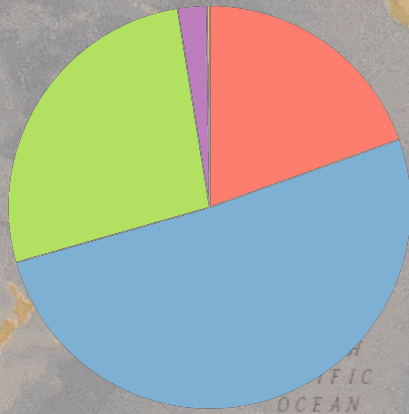
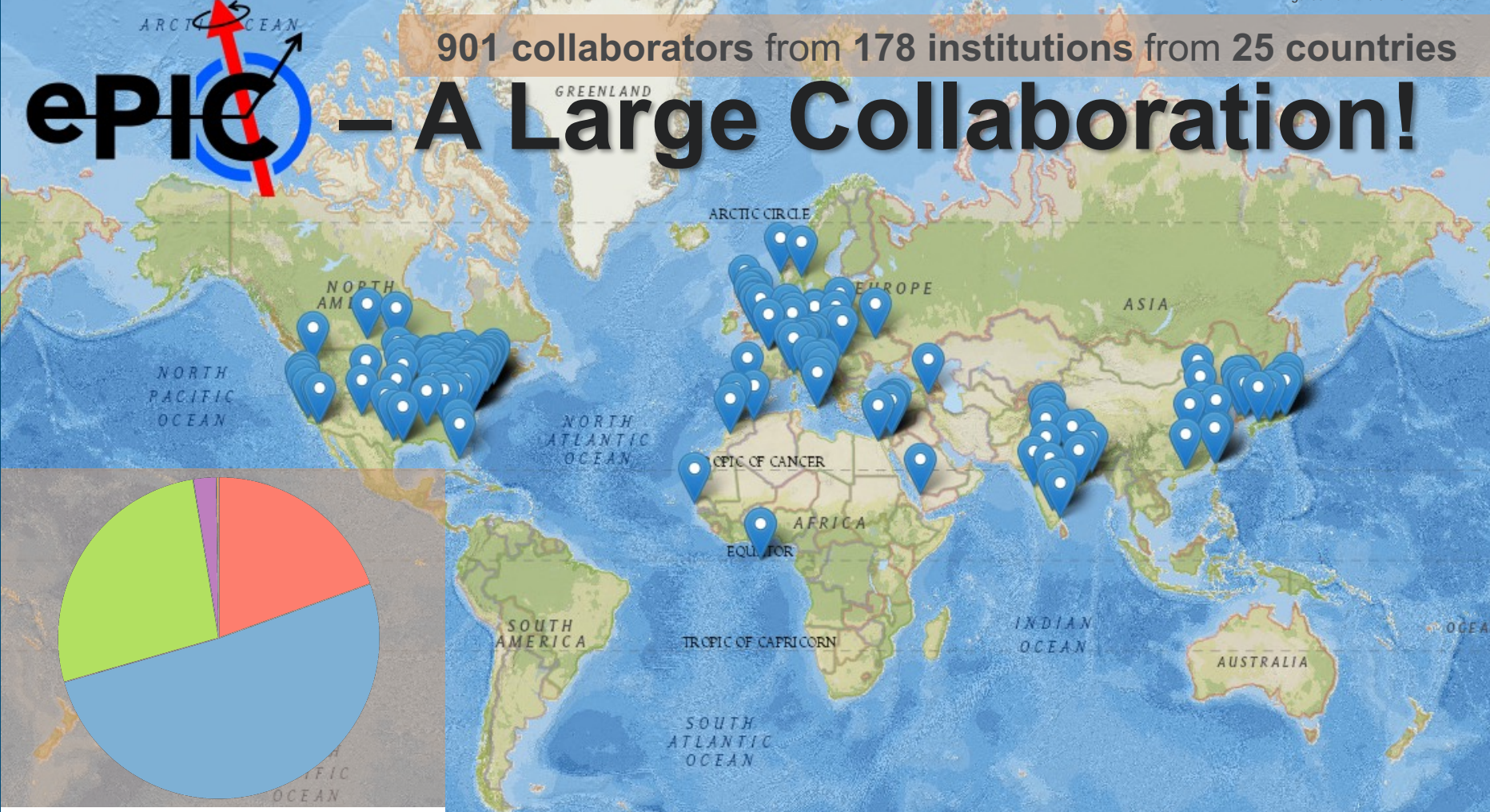

ASIA, 19.53% NORTH AMERICA, 51.05% EUROPE, 26.86% AFRICA, 2.33% UNSPECIFIED, 0.22%

(pre)TDR Strategy and Publications

The EIC (pre)TDR is the top priority for the ePIC Collaboration

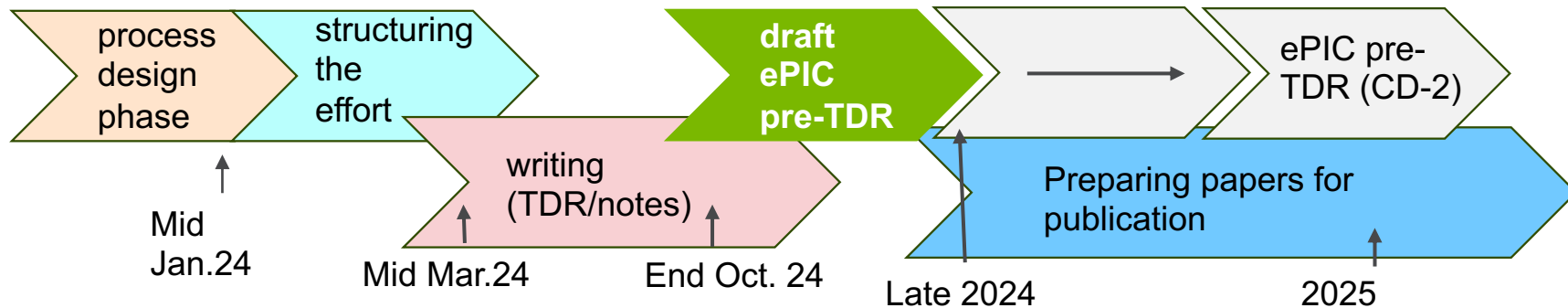

Timeline driven by the EIC Project (CD-2/CD-3)

Extended versions of the sections on the detector, physics performance, and software & computing to be published in scientific journals

EIC Science During Commissioning

Ongoing ePIC + EIC Project Evaluation Based on Phasing EIC Operation

Phase I: Under Discussion

- HSR: low-energy cooling up to injection energy, no 41-GeV bypass
- ESR: 5-10 GeV, 7 nC max (means fewer rf cavities and amps); maybe no crabs (may require lower proton bunch intensities)
- RCS: operates with a 7-nC (single bunch), 3 → 5 or 10 GeV, ramps at 1 Hz

Phase II: Under Discussion

- HSR: potentially add high-energy cooling, add 41-GeV bypass
- ESR: add rf cavities and power to operate at 28 nC and 18 GeV;
- RCS: upgraded to 28 nC and 3 → 18 GeV ramps (at 1 Hz);

Start science program while ramping up EIC capabilities is driven by:

- Start of EIC Science program.
- Alignment with expected order in commissioning the collider and ramp up of performance that comes with gain of operational experience.
- Having access to new physics results early to get high impact publications.

e-p Luminosity in EIC Phase I

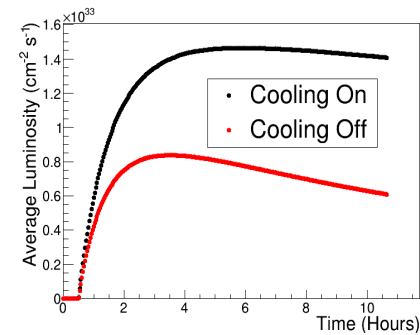
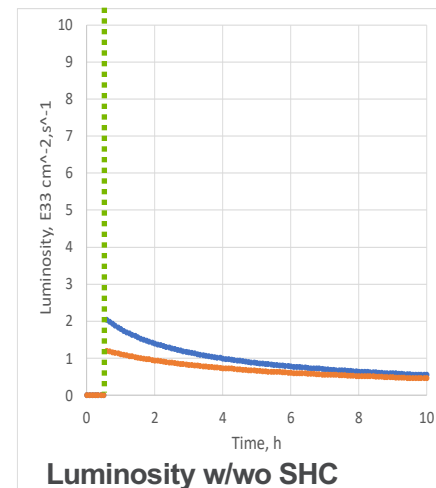

ePIC at EIC

A Detector Designed for Precision QCD

ePIC at the EIC will enable us to explore nucleon structure and observed properties in terms of the quark and gluon dynamics.

The ePIC collaboration is large for NP: over 900 scientists from 178 institutions across 25 countries

The ePIC detector will be a **highly integrated, multi-purpose detector:**

- State-of-the-art technologies and computing ensure that ePIC will deliver on EIC Science from its start
- Detector design maximizes its physics reach

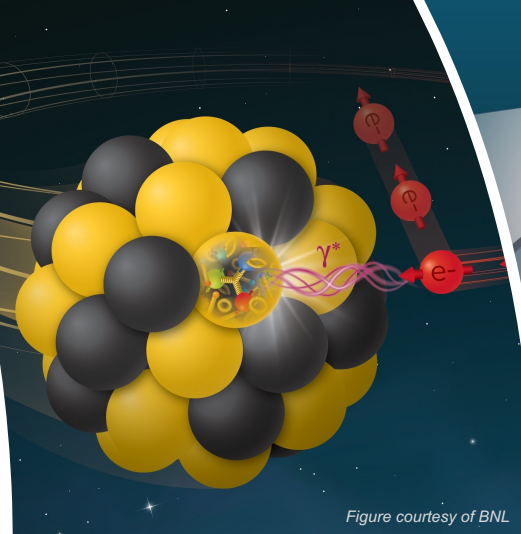

Figure courtesy of BNL

This work is supported by the U.S. Department of Energy, Office of Science, Office of Nuclear Physics, under contract DE-AC02-06CH11357.

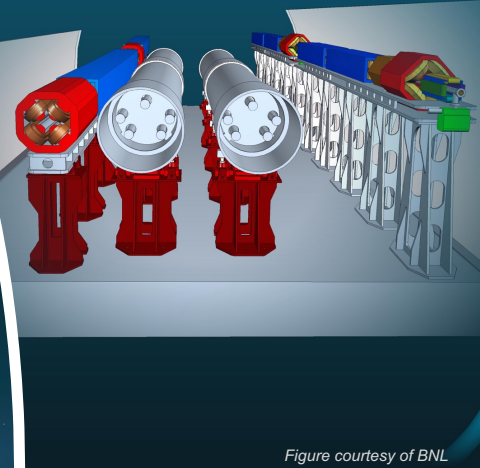
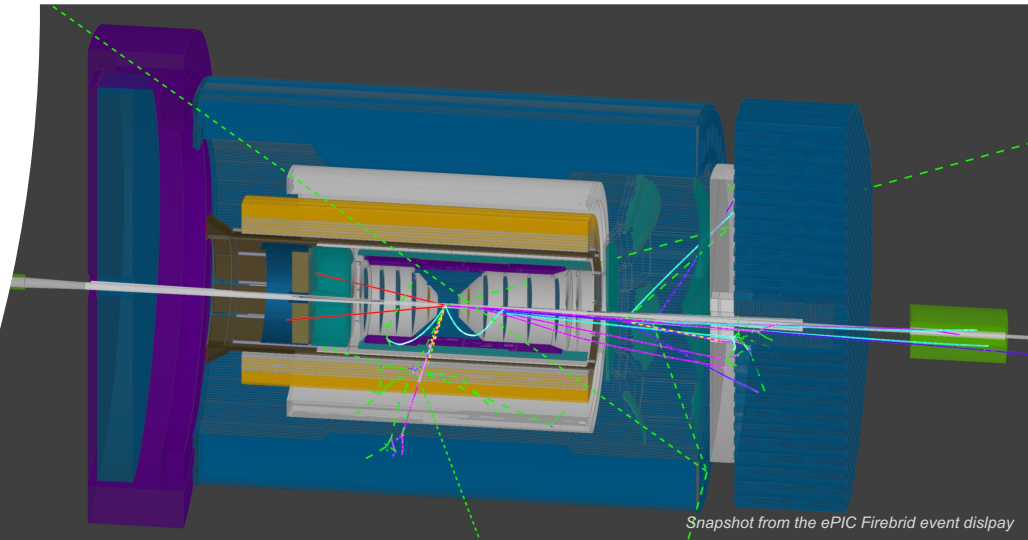

Figure courtesy of BNL



Snapshot from the ePIC Firebird event display

Argonne 
NATIONAL LABORATORY



U.S. DEPARTMENT OF
ENERGY

