

# EIC and ePIC in a nutshell

- Enable the ultimate QCD exploration
  - By a high-luminosity polarized electron-ion collider: **the EIC**
  - By a detector highly integrated with the collider and capable to cope with the overall EIC physics scope, **ePIC**
- **Status :**
  - **EIC is an approved project** progressing towards its realization at BNL in cooperation with JLab
  - **ePIC Collaboration established** with ~ 900 members and high international character

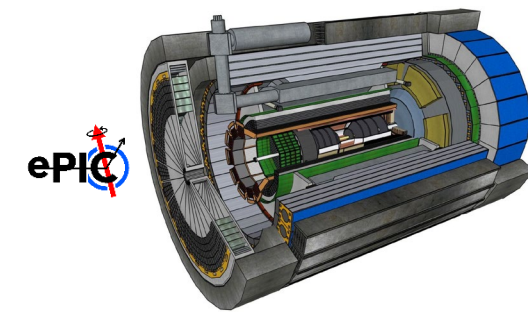

- **The path to the present status**
- **The EIC project and its physics scope**
- **The ePIC detector**

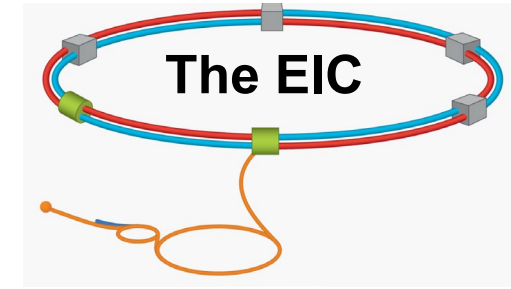
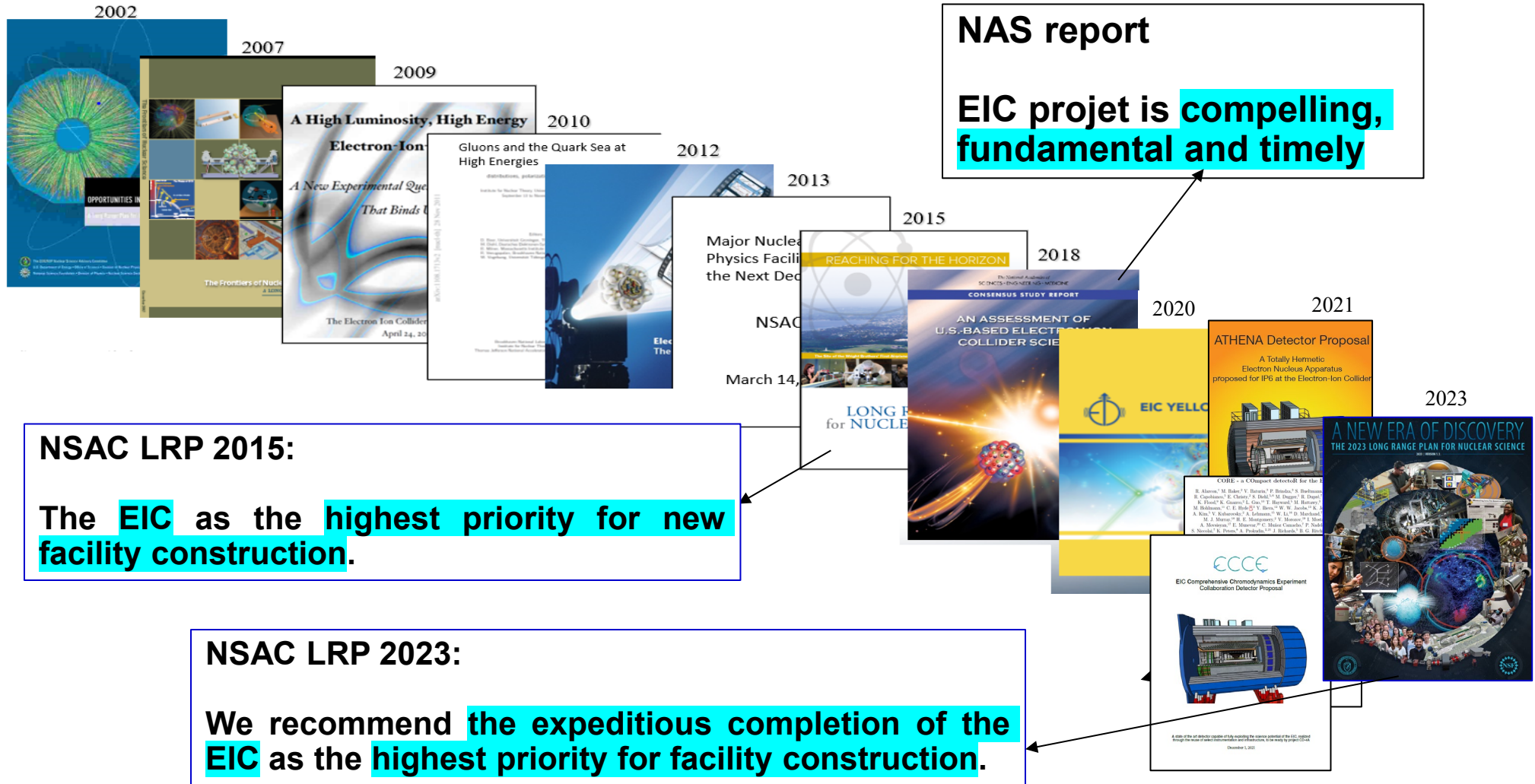

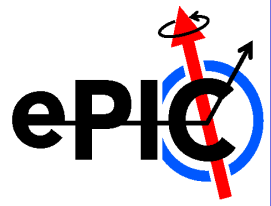

# THE INTERNATIONAL COMMUNITY: the EIC-User Group

The EIC User Group:  
<https://eicug.github.io/>

Formed in 2016 –

- 1550 members
- 40 countries
- 6 world regions
- 303 institutions

As of March 11<sup>th</sup>, 2025

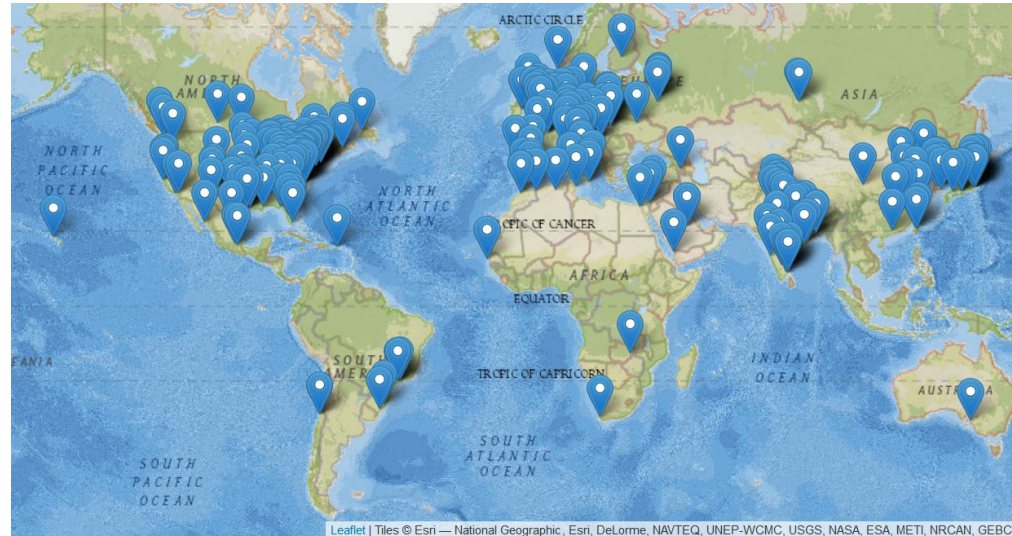

Among the main Achievements:  
The **Yellow Report** (2020)

## Institutions

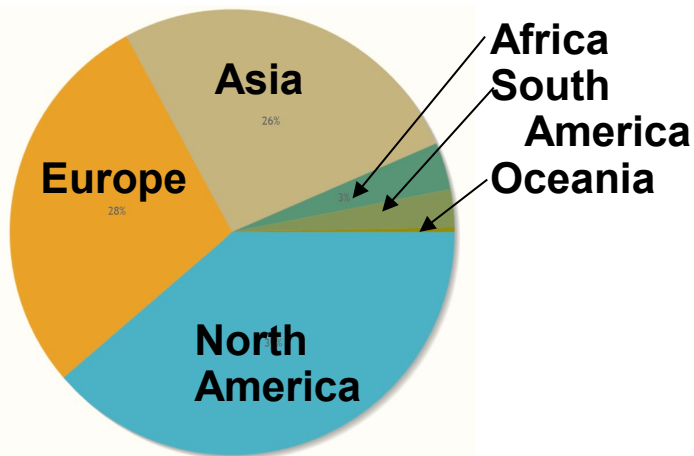

## Annual EICUG meeting

- 2016 UC Berkeley, CA
- 2016 Argonne, IL
- 2017 Trieste, Italy
- 2018 CUA, Washington, DC
- 2019 Paris, France
- 2020 Miami, FL
- 2021 VUU, VA & UCR, CA
- 2022 Stony Brook U, NY
- 2023 Warsaw, Poland
- 2024 Lehigh U., PA
- 2025 JLab, VA



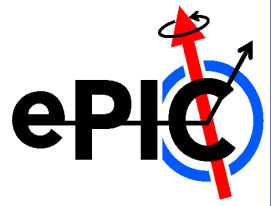

# The ePIC Collaboration

The community dedicated to the EIC science mission  
by the realization of the ePIC detector

Warsaw, July 2023



Lehigh, July 2024



JLab, Jan. 2023



ANL,  
Jan. 2024



Frascati, July 2024



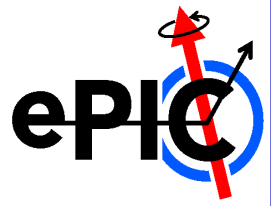

# The ePIC Collaboration

ePIC Institutions  
177

ePIC countries  
26

ePIC World Regions  
4



ePIC initiated  
in July 2022

Currently:

897 collaborators

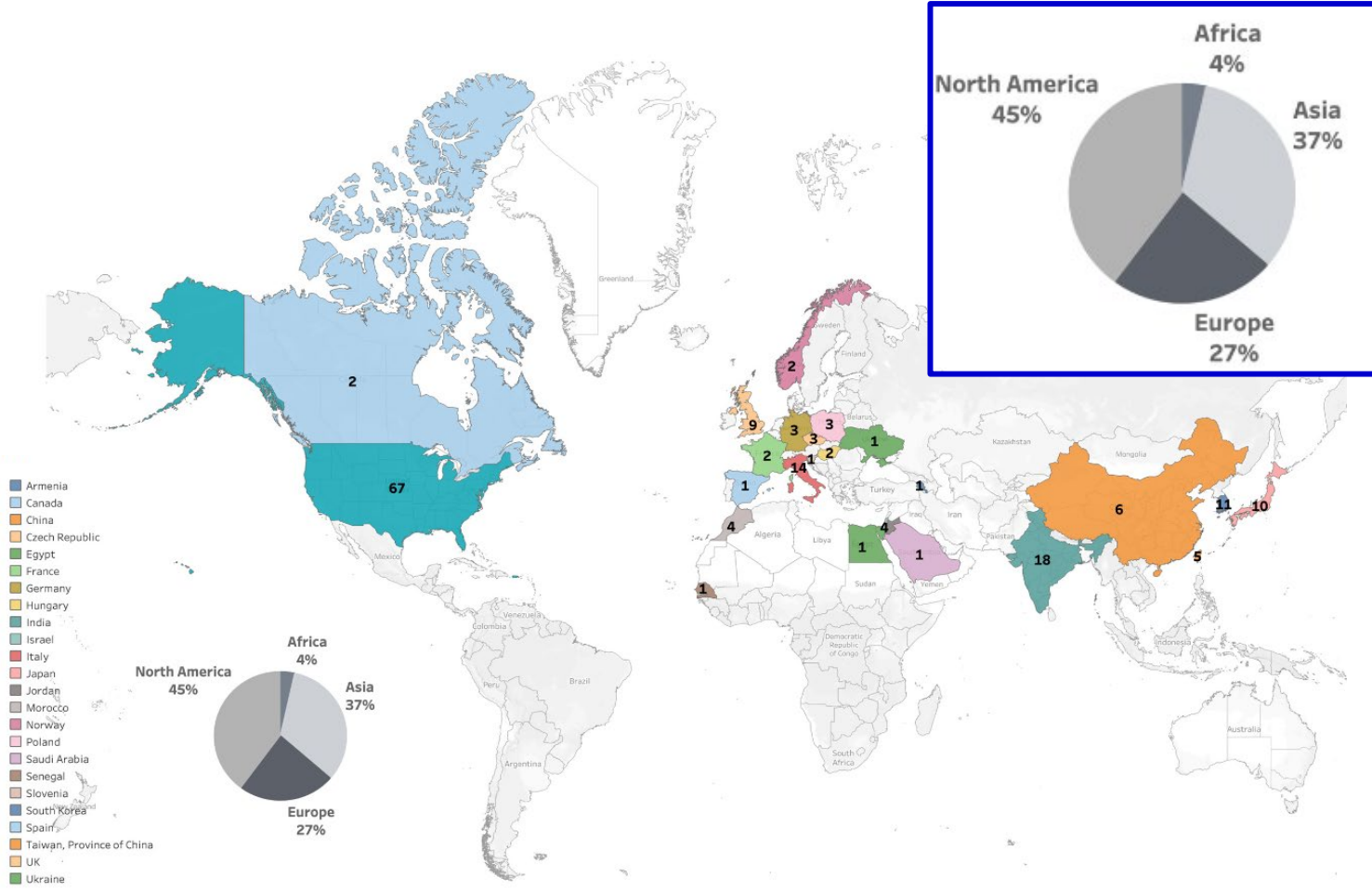

- **The path to the present status**
- **The EIC project and its physics scope**
- **The ePIC detector**

In short words:

*Investigate with precision the universal dynamics of gluons to understand the emergence of hadronic and nuclear matter and their properties*

In terms of major open questions:



How does the **spin** of the nucleon arise?

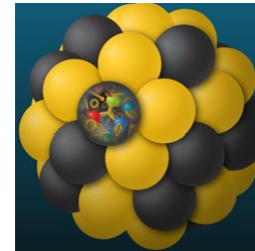

How do quarks and gluons **interact with a nuclear medium**?

How do the **confined hadronic states** emerge?

How do the quark-gluon interactions create **nuclear binding**?



How does the **mass** of the nucleon arise?

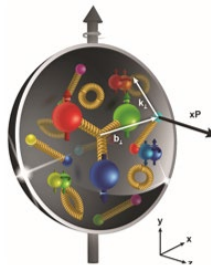

How are the **quarks and gluon distributed in space and momentum** inside the nucleon and nuclei?

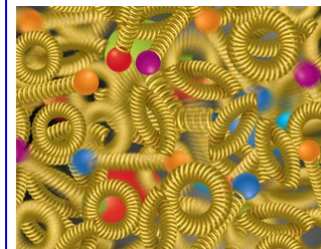

What are the emergent properties of **dense system of gluons**?

## REQUIREMENTS

- **Access to gluon dominated region and wide kinematic range in  $x$  and  $Q^2$**
- **Access to spin structure and 3D spatial and momentum structure**
- **Accessing the highest gluon densities ( $(Q_s^A)^2 \sim cQ_0^2 \left(\frac{A}{x}\right)^{1/3}$ )**
- **Studying observables as a function of  $x$ ,  $Q^2$ ,  $A$ , hadronic flavour, ...**

## THE EIC COLLIDER PROVIDES

- ***Large center-of-mass energy range:***  
 $\sqrt{s} = 28 - 140 \text{ GeV}$
- ***Polarized electron, proton and light nuclear beams  $\geq 70\%$***
- ***Nuclear beams, the heavier the better (from H to U)***
- ***High luminosity (100 x HERA):***  
 $10^{33-34} \text{ cm}^{-2} \text{ s}^{-1}$

## Usage of RHIC tunnel and RHIC p/ion complex

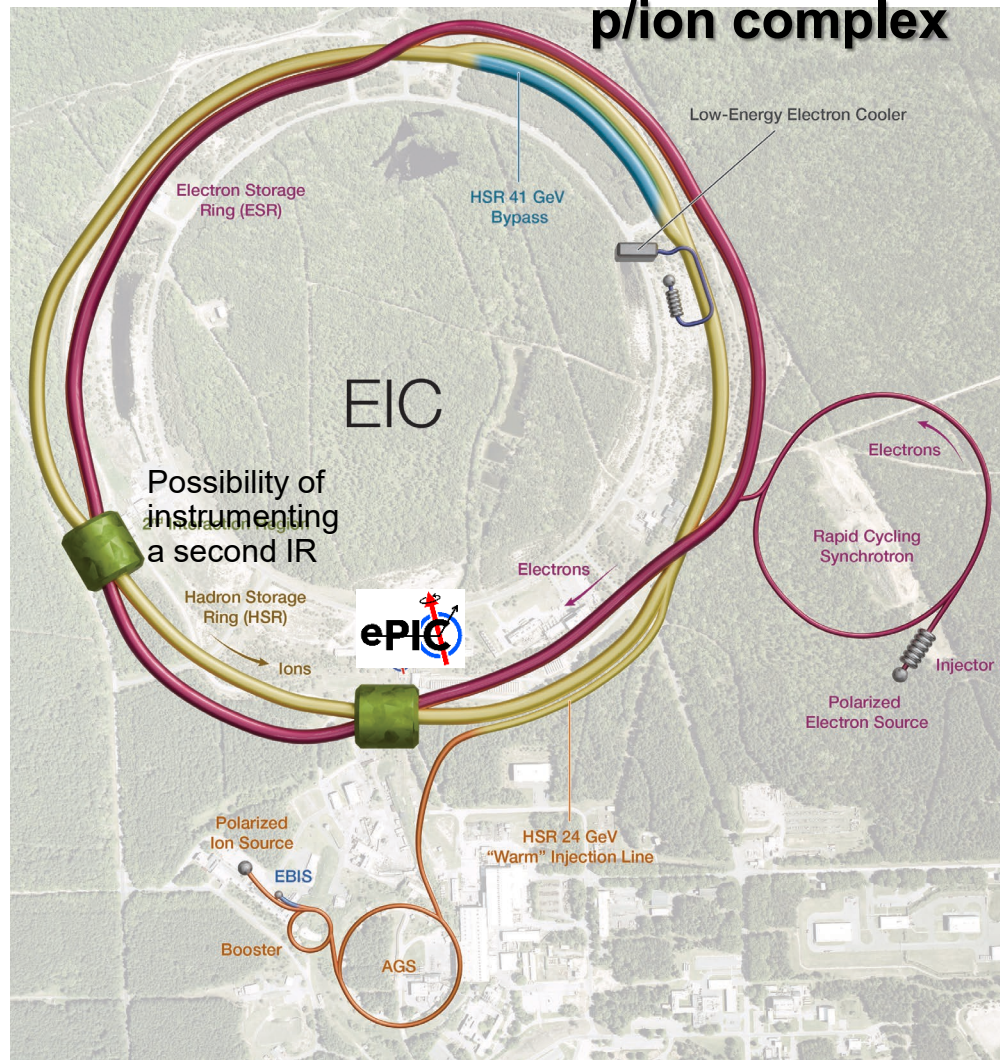

## Design parameters

- **ep ECM: 28-141 GeV**
  - 2 decades increase in kinematic coverage in  $x$  and  $Q^2$  respect to fix target
- **ep/eA luminosity up to  $10^{33}$ - $10^{34}$  cm<sup>-2</sup> s<sup>-1</sup>**
  - > 100 time higher luminosity as HERA
- **e, p beam polarization : 70% → unique opportunity**
  - Polarization of light nuclei
- **Ions from H to U → ample variety**
  - Up to the highest density gluon systems

## Polarized e-p DIS

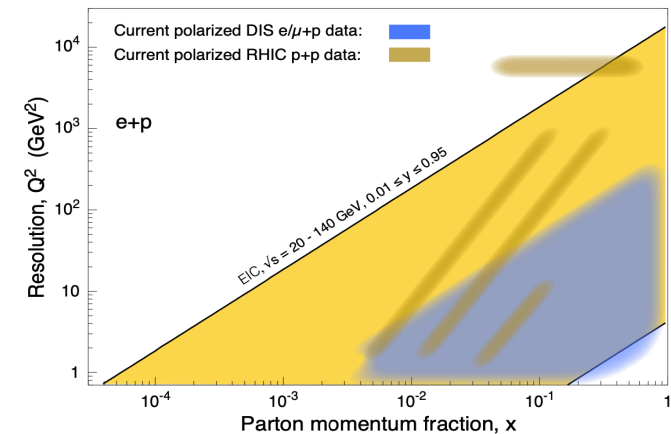

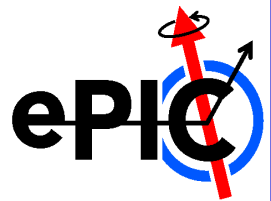

# The EIC Collider

## Usage of RHIC tunnel and RHIC p/ion complex

## Design parameters

- ep ECM: 28-140 GeV
- 2 detectors

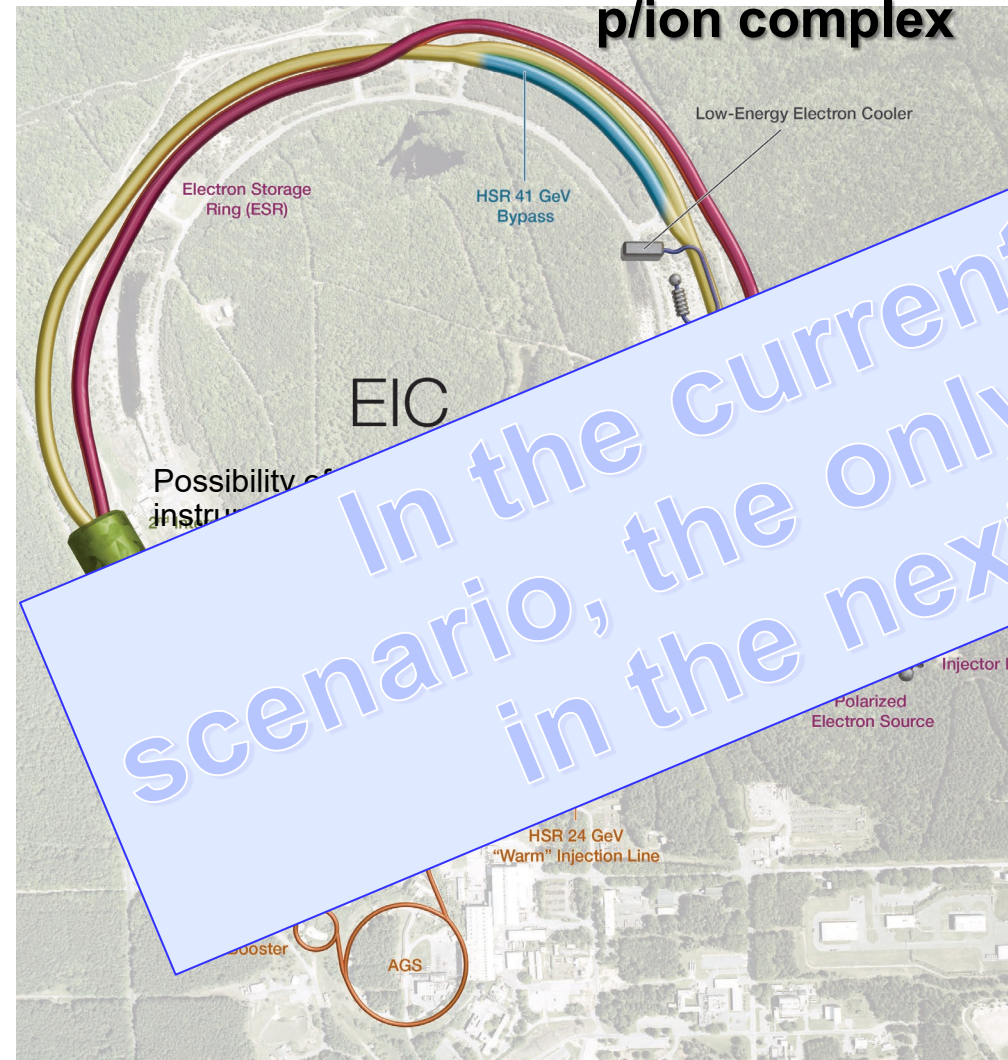

In the current worldwide scenario, the only novel HE collider in the next 10-20 years

- from H to U → ample variety
- Up to the highest density gluon systems
- 70% → unique opportunity
- of light nuclei

## Polarized e-p DIS

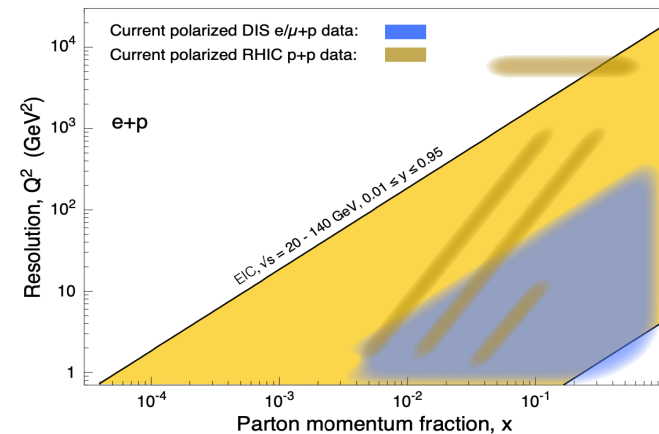

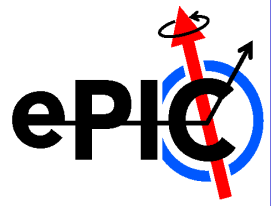

# The EIC Collider

## 4 critical ingredients for HIGH LUMINOSITY

### Coherent Cooling with FEL amplifier

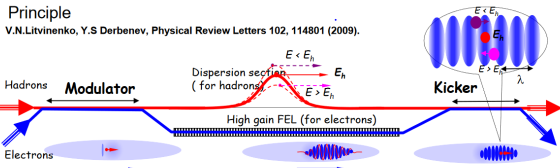

→ cooling of high energy Hadron beams with high band-width; BW: 1THz short cooling times to balance strong IBS

Proof of Principle Experiment at BNL, ongoing

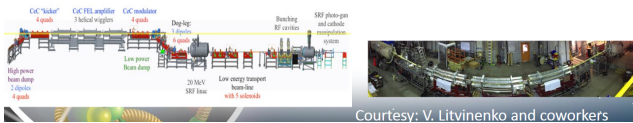

Courtesy: V. Litvinenko and coworkers

### Bunches and beam crossing rates

Species	$p$	$e$	$p$	$e$	$p$	$e$	$p$	$e$	$p$	$e$
Beam energy [GeV]	275	18	275	10	100	10	100	5	41	5
$\sqrt{s}$ [GeV]	140.7		104.9		63.2		44.7		28.6	
No. of bunches	290		1160		1160		1160		1160	

Species	Au	$e$	Au	$e$	Au	$e$	Au	$e$
Beam energy [GeV]	110	18	110	10	110	5	41	5
$\sqrt{s}$ [GeV]	89.0		66.3		46.9		28.6	
No. of bunches	290		1160		1160		1160	

Up to a beam crossing rate at the IR every 10ns  
a challenge for the collider and the experiment !

### Strong Hadron Cooling

- Work continues on Strong Hadron Cooling, both the Coherent electron Cooling (CeC) approach and a backup solution based on a ring cooler
- Both approaches were reviewed in summer, no show stoppers found in either one

Small  $\beta_y^*$

→ quads close to IP leaving ~10 m for the detector

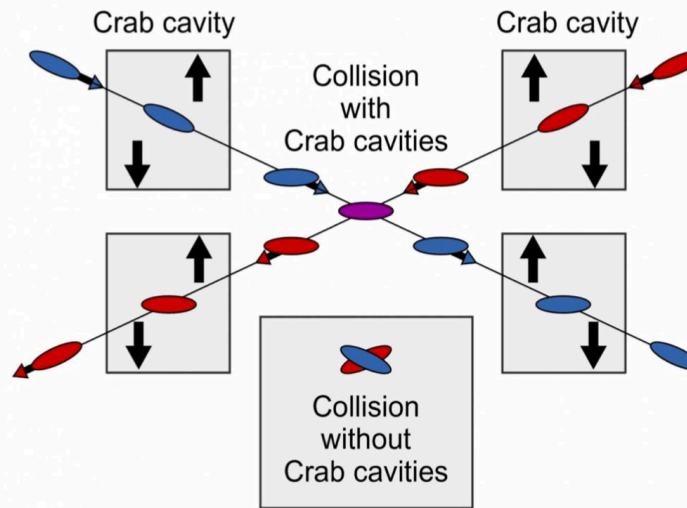
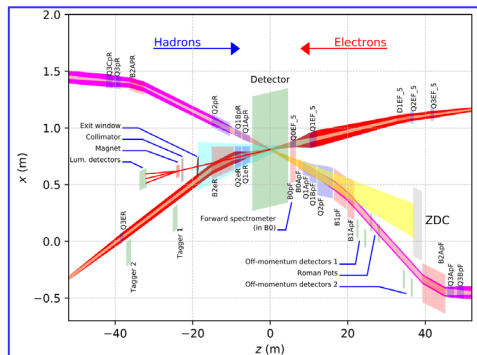

**CRAB CROSSING ANGLE (25 mrad)** to restore head-on collisions

## MORE unique aspects

## BEAM POLARIZATION

### ION SPECIES

The existing RHIC ion sources & ion acceleration chain provides already **today** all ions needed at EIC

Enormous versatility!  
is a unique capability!

Ion Pairs in the RHIC Complex	
Zr-Zr, Ru-Ru	(2018)
Au-Au	(2016)
d-Au	(2016)
p-Al	(2015)
h-Au	(2015)
p-Au	(2015)
Cu-Au	(2012)
U-U	(2012)
Cu-Cu	(2012)
D-Au	(2008)
Cu-Cu	(2005)

### ABOUT e POLARIZATION

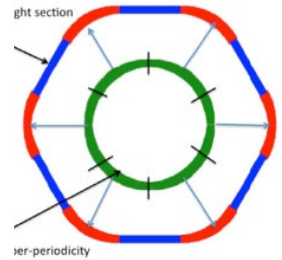

→ resonance free acceleration up >18 GeV

on average, every bunch refilled in 2.2 min

### ABOUT p/ light ion POLARIZATION

presently

#### Measured RHIC Results:

- Proton Source Polarization 83 %
- Polarization at extraction from AGS 70%
- Polarization at RHIC collision energy 60%

empowerment

#### Planned near term improvements:

- AGS:** Stronger snake, skew quadrupoles, increased injection energy  
→ expect 80% at extraction of AGS
- RHIC:** Add 2 snakes to 4 existing no polarization loss  
→ expect 80% in Polarization in RHIC and eRHIC

High polarization <sup>3</sup>He and D beams also possible

# The EIC schedule

## Design phase

## Construction phase

## Science Phase

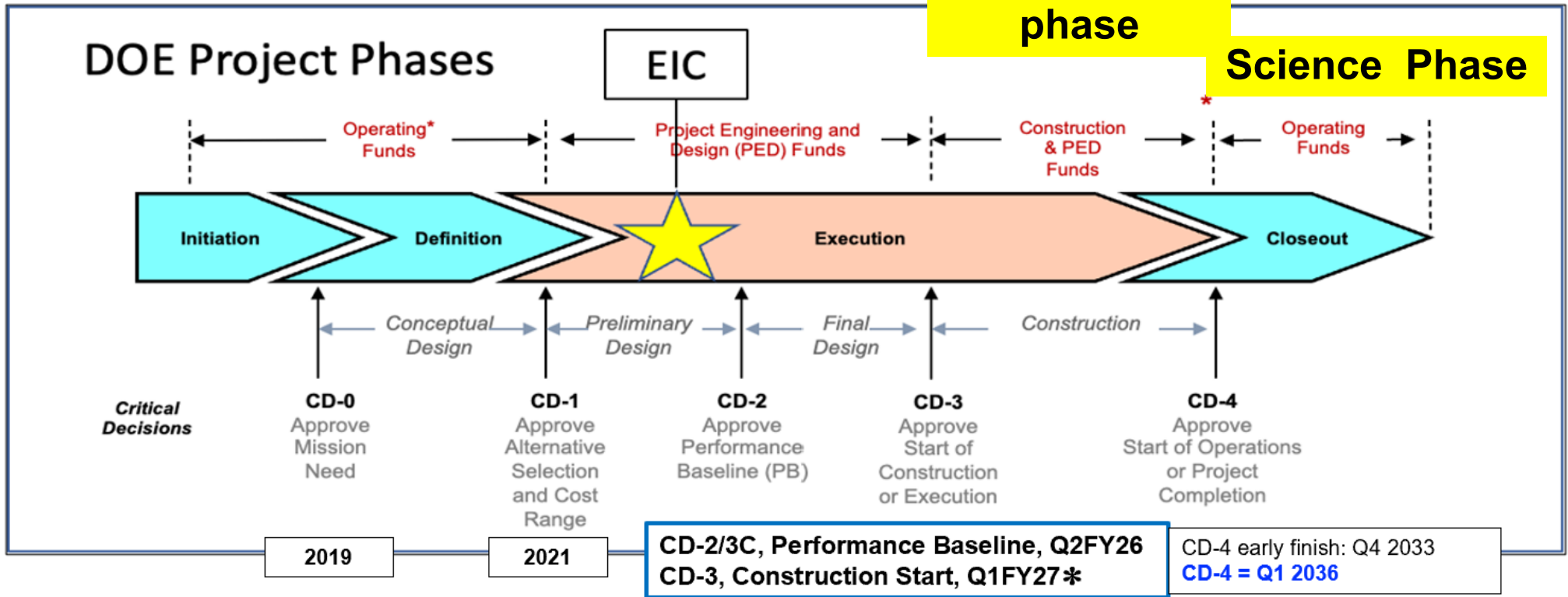

- CD-3A, Long Lead Procurement, approved March 2024. Excellent use of IRA funding.
- CD-3B, Long Lead Procurement, approval planned for March 2025.
- CD-2, Project Performance Baseline, requires a more certain annual funding profile.

\* FY25 and FY26 funding will impact CD-2 and CD-3 milestone dates.

- **The path to the present status**
- **The EIC project and its physics scope**
- **The ePIC detector**

## REQUIREMENTS



## ePIC detector

Measurement categories to address EIC physics:

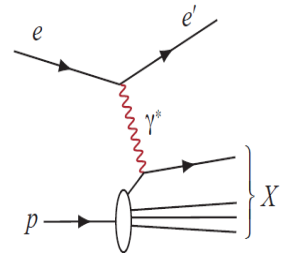

- Inclusive DIS
  - ▶ fine multi-dimensional binning in  $x, Q^2$

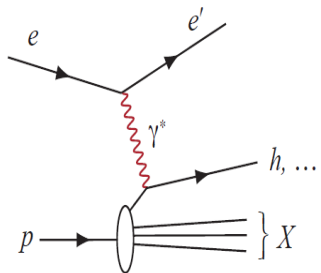

- Semi-inclusive DIS
  - ▶ 5-dimensional binning in  $x, Q^2, z, p_T, \theta$

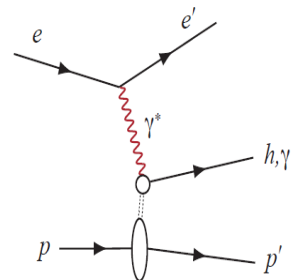

- Exclusive processes
  - ▶ 4-dimensional binning in  $x, Q^2, t, \theta$  to reach  $|t| > 1 \text{ GeV}^2$

- **Large coverage** ( $-3.5 < \eta < 3.5$ ) for wide phase-space reach
- **Excellent EM-calorimetry with PID support for  $e/\pi$  separation**
- **Fine resolution tracking by low mass detectors**

- **Fine  $p_T$  resolution**
- **Extended PID systems for hadron identification**
- **H-calorimetry to attempt TMD assessment with jets (new world-wide), as tail catcher, for  $\mu$  identification**

- **Extend acceptance at extremely small scattering angles**
- **Fine vertex resolution by tracking**



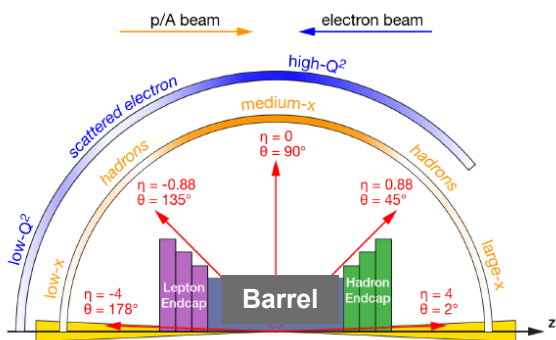

Very naturally organized in:

- Backward endcap
- Barrel
- Forward endcap subsystems

- hadronic calorimeters
- Solenoidal Magnet
- e/m calorimeters (ECal)
- Time of Flight, DIRC, RICH detectors
- MPGD trackers
- MAPS tracker

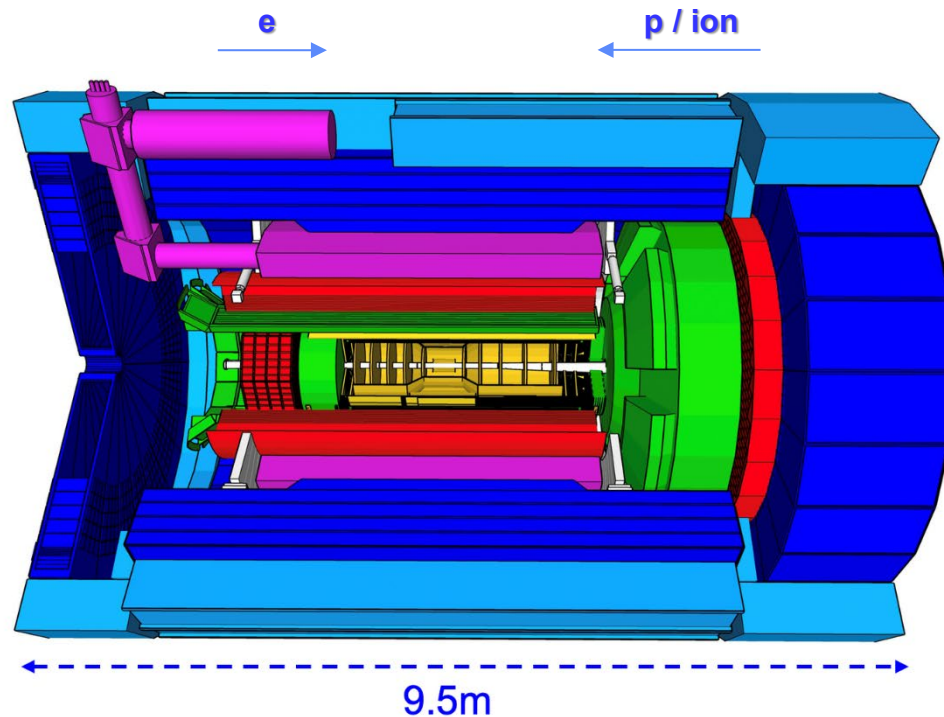

# The ePIC solenoid

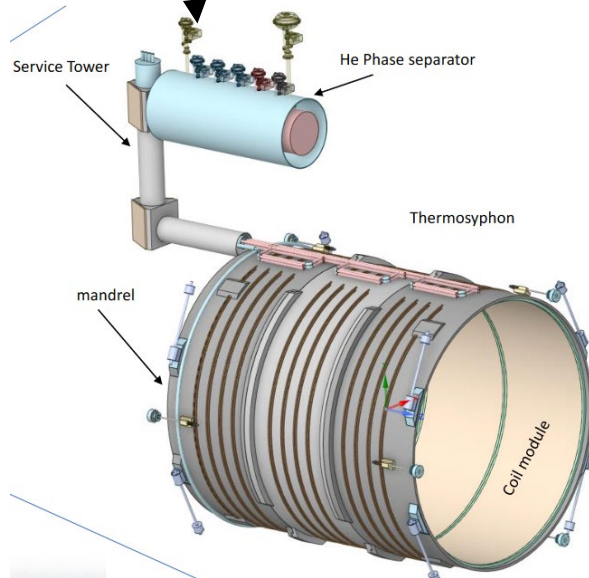
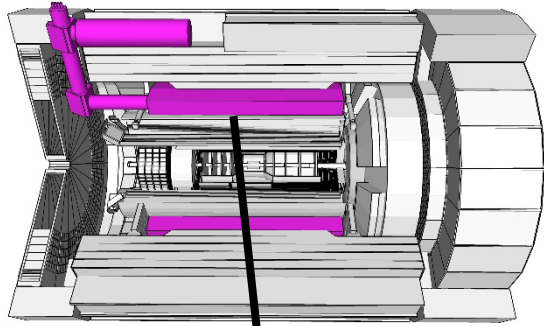

Parameter	Value
Coil length	3512 mm
Warm bore diameter	2840 mm
Cryostat length	< 3850 mm
Cryostat outer diameter	< 3540 mm

Parameter	Value	Comment
Central Field $B_0$	2.0 T	Reference field value: 1.7 T
Lowest operating field	0.5 T	
Field Uniformity in FFA	12.5 %	Magnetic Field Properties
	$\pm 100$ cm around center 80 cm radius	
Projectivity in RICH Area	< 0.1 (mrad@30GeV/c) < 10 T/A/mm <sup>2</sup> From Z = 180 cm to 280 cm	

Parameter	Value	Comment
B5300 (B @ Z= -5300 mm)	< 10 G	Stray field requirement is based on IR magnet location
B7400 (B @ Z= 7400 mm)	< 10 G	
B3400 (B @ R= 3400 mm)	< 10 G	

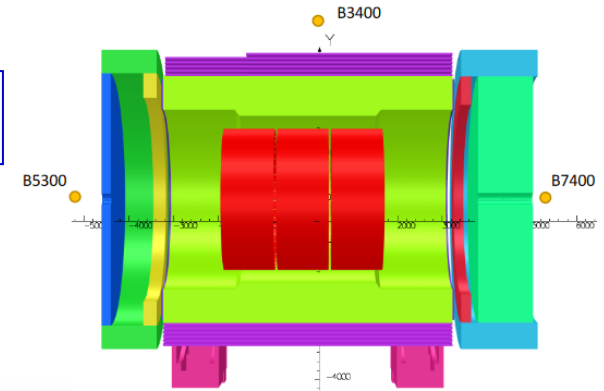

## Conductor Design

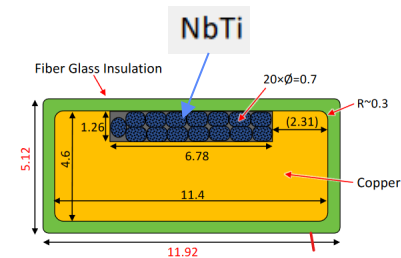

# TRACKING IN ePIC CD

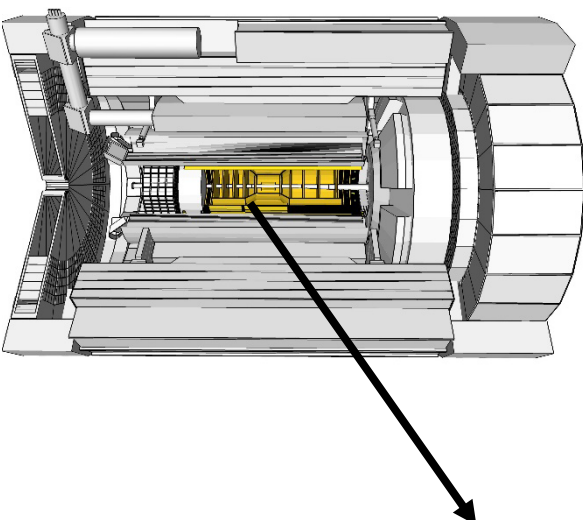

Complementary tracking technologies characterized by light materials

**SVT:** Si trackers based on ALICE ITS3 65 nm MAPS sensors

- Fine space resolution < 5  $\mu\text{m}$
- Five cylindrical layers in the barrel and five disks in each endcap

**MPGD trackers**

- Good time resolution  $\mathcal{O}$  (10 ns)
- Cylindrical **MICROMEGAS**
- Planar  $\mu\text{R-WELL}$  with **GEM pre-amplification**

Additional information

- **AC-LGADs** for ToF (PID) - very fine time resolution: 20/30 ps
- First layer of the barrel **imaging EM calorimeter** – fine space resolution (150  $\mu\text{m}$ ), good time resolution ( $\sim 2$  ns)

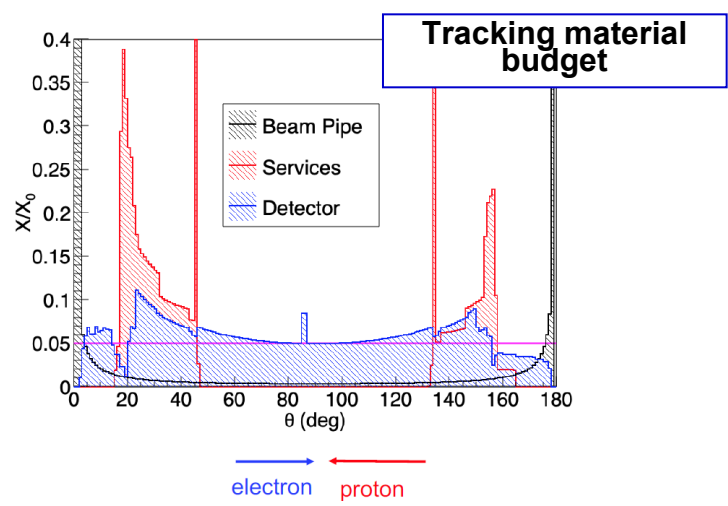
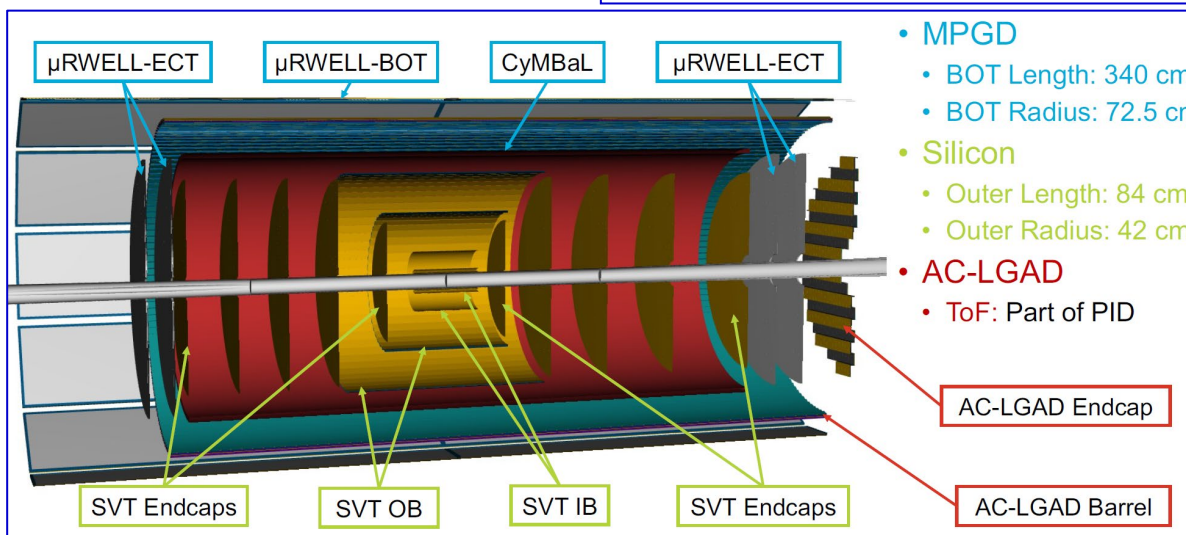

## SiPM sensors for all Calorimeters in ePIC

- SiPMs recently introduced in calorimetry
- direct experience is coming from the applications in GlueX, STAR and sPHENIX
- these colleagues now at work for ePIC calorimetry

## Relevant SiPM features for ePIC calorimetry

- **Cost-effective** technology
- Operation in **magnetic field**
- Wide **dynamic range** with tuned parameters for the different calorimeters
- Low **noise** with appropriate thresholding
- Effect of the radiation
  - Not new, already addressed for STAR and sPHENIX
  - Further irradiation campaigns on-going

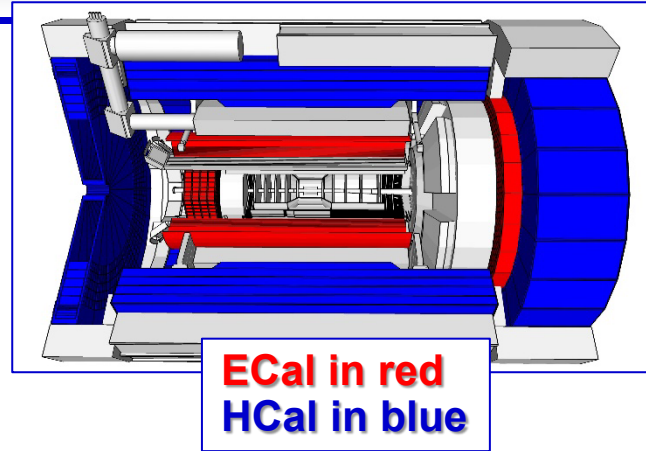

## SiPM requirements for HCals

Parameter	Value
Size	1.3mm x 1.3mm
Pixel size	15 $\mu\text{m}$
Photon Detection Efficiency (PDE)	>25%
Dark Count Rate (DCR)	<400 kHz
Gain	> $5 \cdot 10^5$
Fill factor	>40%
Peak sensitivity	$\sim 450 \text{ nm}$

## Rad Dose and Neutron Flux

10x275GeV e+p @ 500.0 kHz, 1 fb<sup>-1</sup> min-bias integrated lumi.

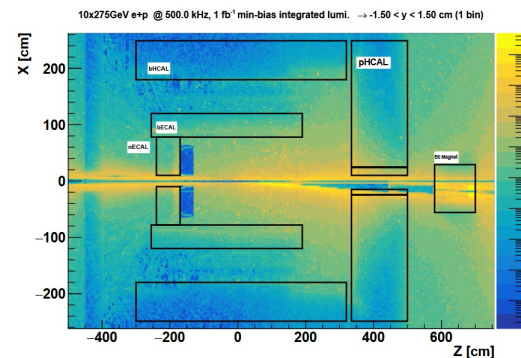

10x275GeV e+p @ 500.0 kHz, 1 fb<sup>-1</sup> min-bias integrated lumi.

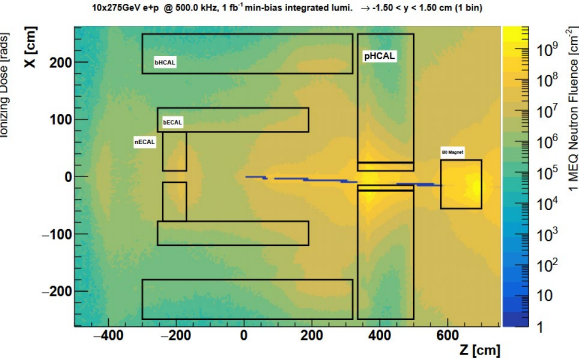

Doses and fluxes  $\sim 10^{-3}$  compared to HL-LHC

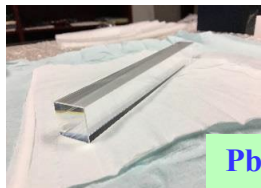
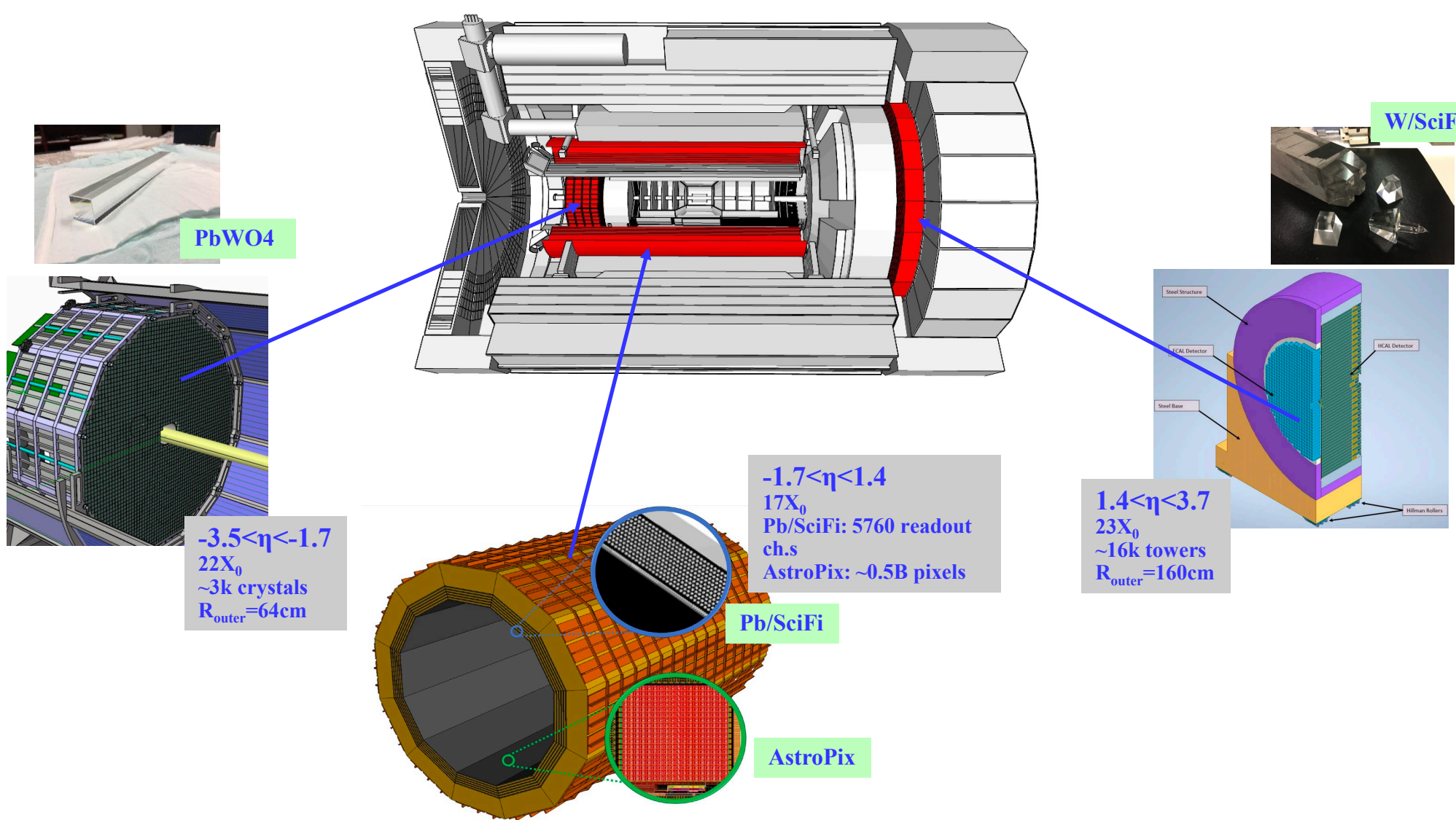

PbWO4

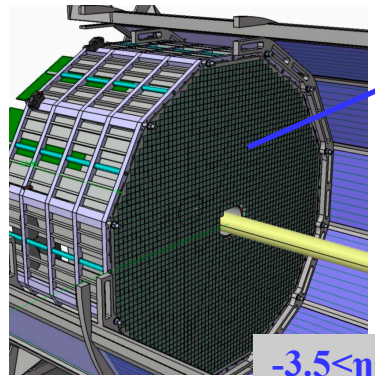

$-3.5 < \eta < -1.7$   
 $22X_0$   
 ~3k crystals  
 $R_{outer} = 64\text{cm}$

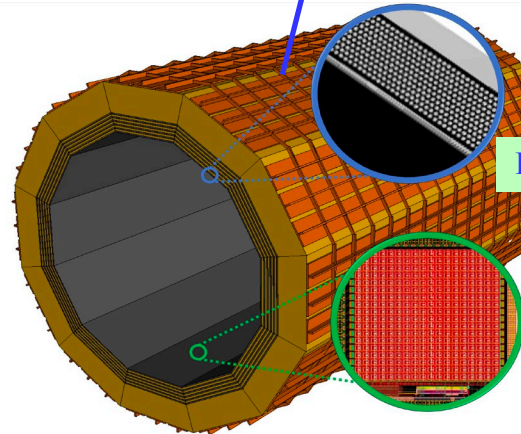

Pb/SciFi

$-1.7 < \eta < 1.4$   
 $17X_0$   
 Pb/SciFi: 5760 readout ch.s  
 AstroPix: ~0.5B pixels

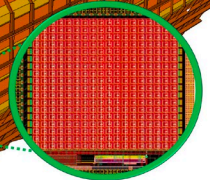

AstroPix

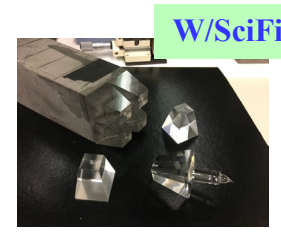

W/SciFi

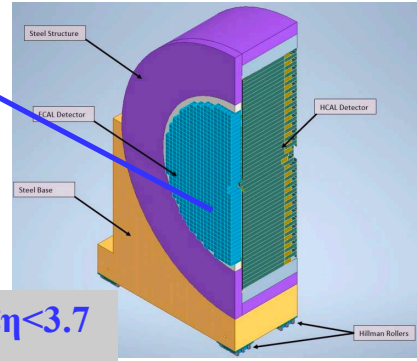

$1.4 < \eta < 3.7$   
 $23X_0$   
 ~16k towers  
 $R_{outer} = 160\text{cm}$

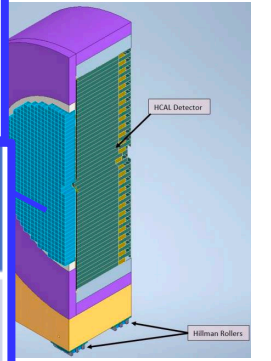
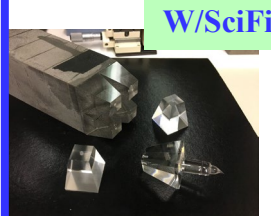
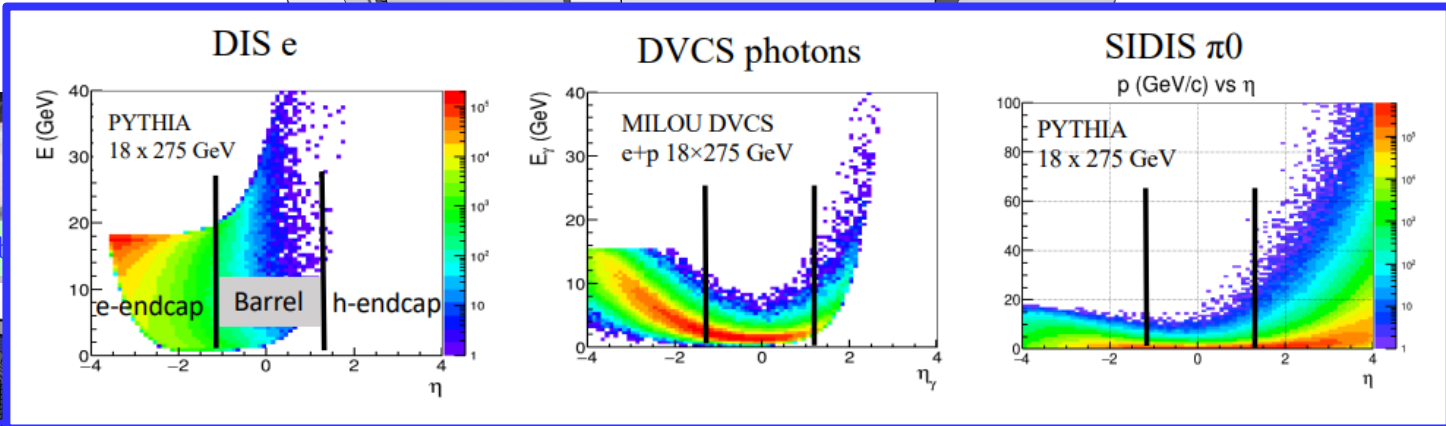

	$\sigma_E/E$	E range, GeV	$\pi^\pm$ suppression (In combination with other subsystems)	$\pi^0/\gamma$ discr.
e-endcap	$\frac{(2-3)\%}{\sqrt{E}} \oplus (1-2)\%$	0.05-18 GeV	Up to $10^4$	Up to 7 GeV/c
Barrel	$\frac{(7-10)\%}{\sqrt{E}} \oplus (1-3)\%$	0.05-50 GeV	Up to $10^4$	Up to 10 GeV/c
h-endcap	$\frac{(10-12)\%}{\sqrt{E}} \oplus (1-3)\%$	0.1-100 GeV	Up to $10^4$	Up to 50 GeV/c

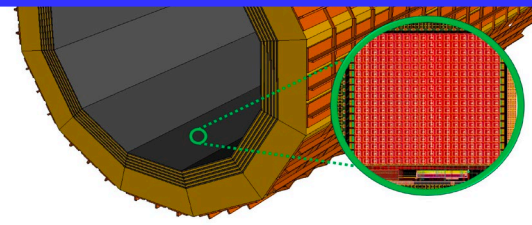

AstroPix

## Backward and barrel:

Steel/scintillator sampling calorimetry - CONSOLIDATED TECHNOLOGY

- Identification of neutral hadron jets, especially at low  $x$
- Tail catcher for e/m calorimeter
- $\mu$  identification

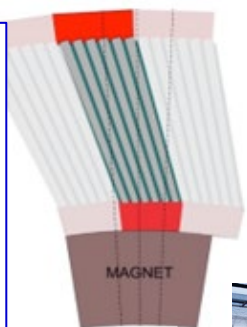

Barrel Hcal  
(re-use from sPHENIX)

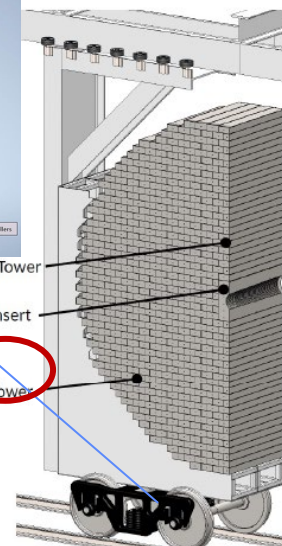
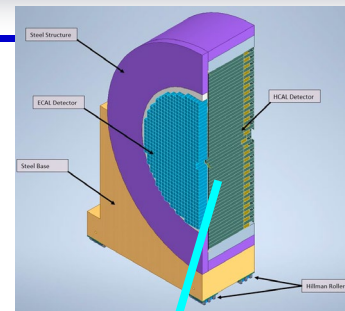

## Forward endcap

- Original design inspired by CALICE development:
- **“SiPM on TILE”**
- High granularity insert at high  $\eta$
- Jet energy measurement
- DIS kinematics reconstruction “Hadronic method”
- muon ID

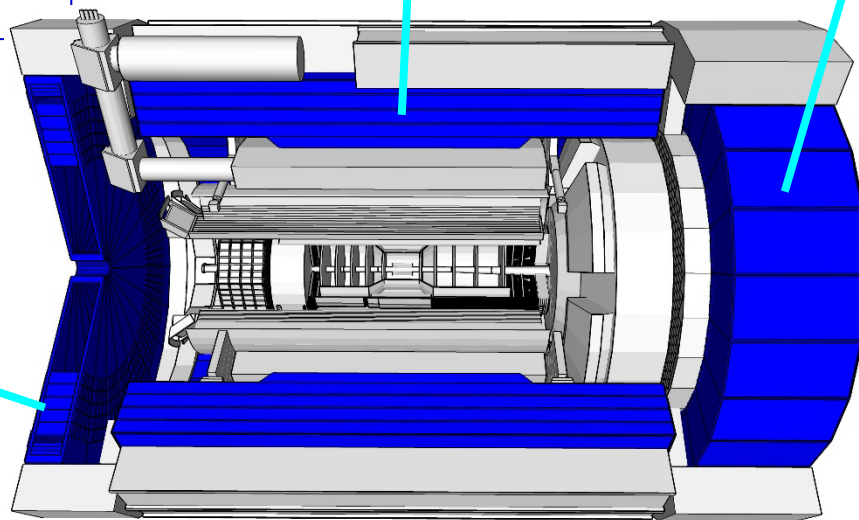
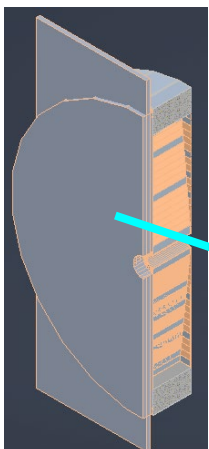

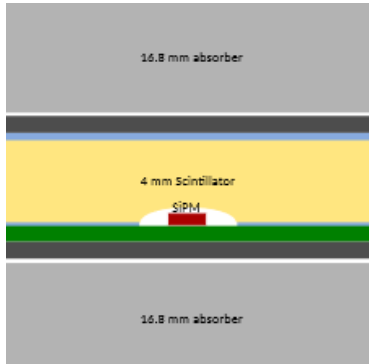

**EHal in forward endcap: “SiPM on tile”**

- Sampling calorimetry with Fe absorber
- Derived by a development for CALICE
- Tower structure with read-out at the rear face

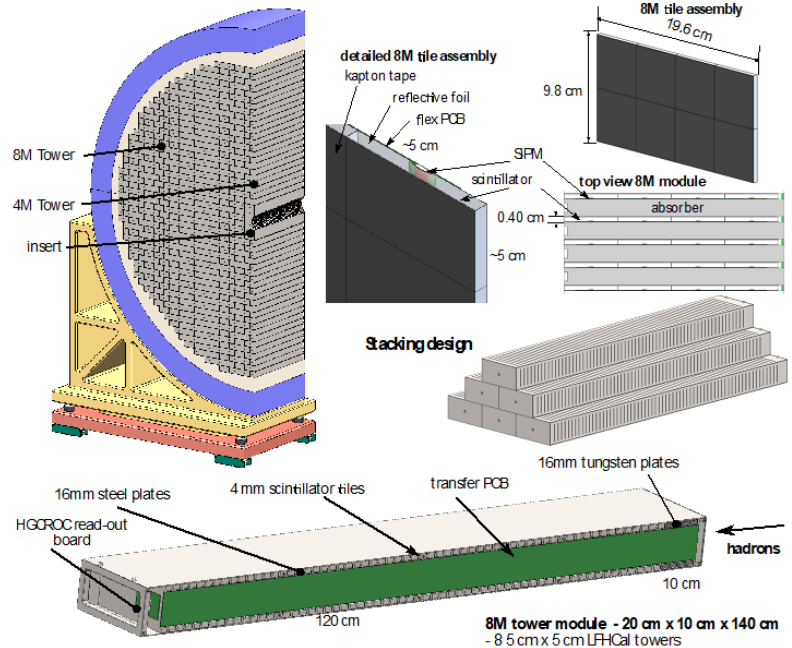
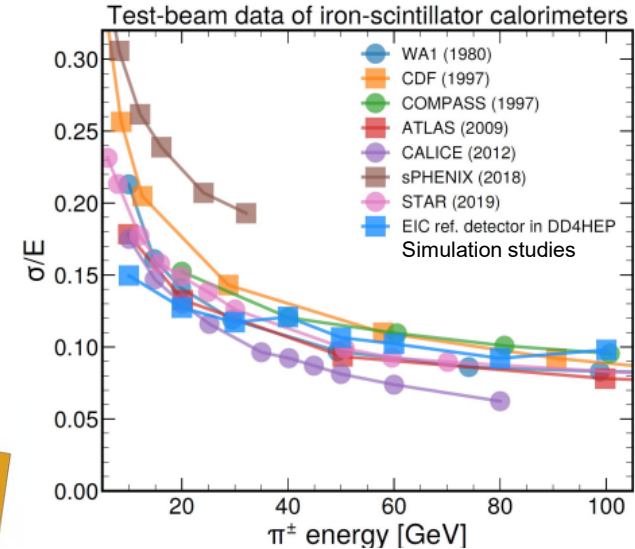

## The Insert

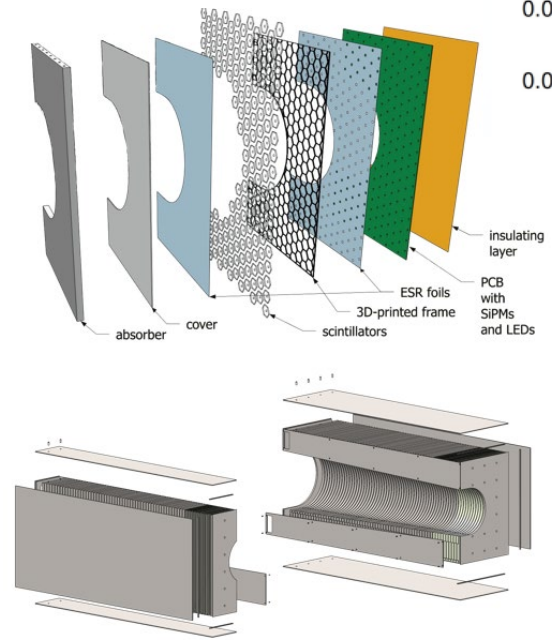

**with staggered tiles for improved space resolution**

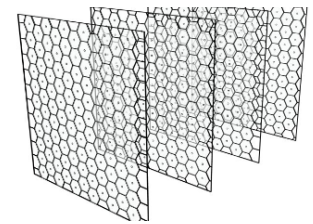

**Support electron identification**, which cannot be provided by ECals only in DIS experiments with electron beams (see HERMES, JLab)

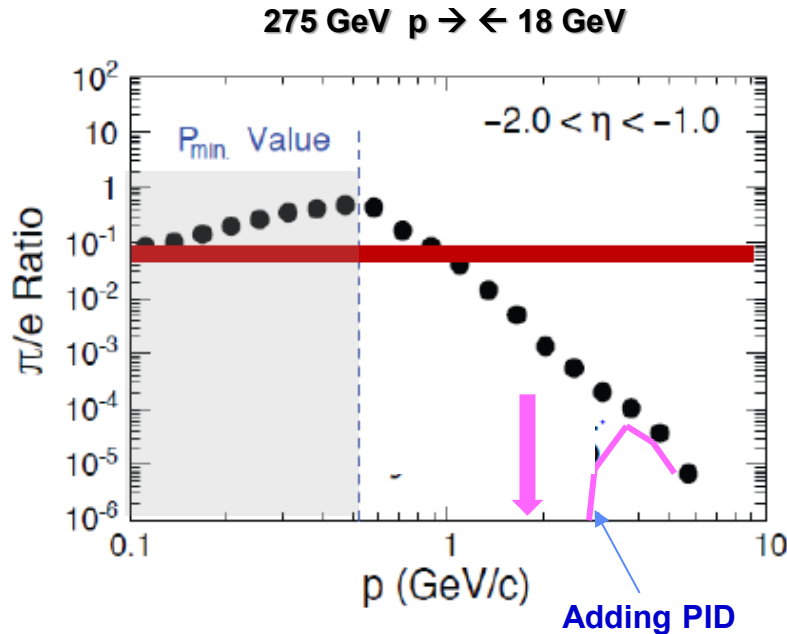

The different physics channels require  $\pi$  contamination in the electron sample down to  $10^{-4}$

**Hadron identification**, a key ingredient for TMDs address by SIDIS and with the novel approach of jet reconstruction

Momentum coverage of hadrons

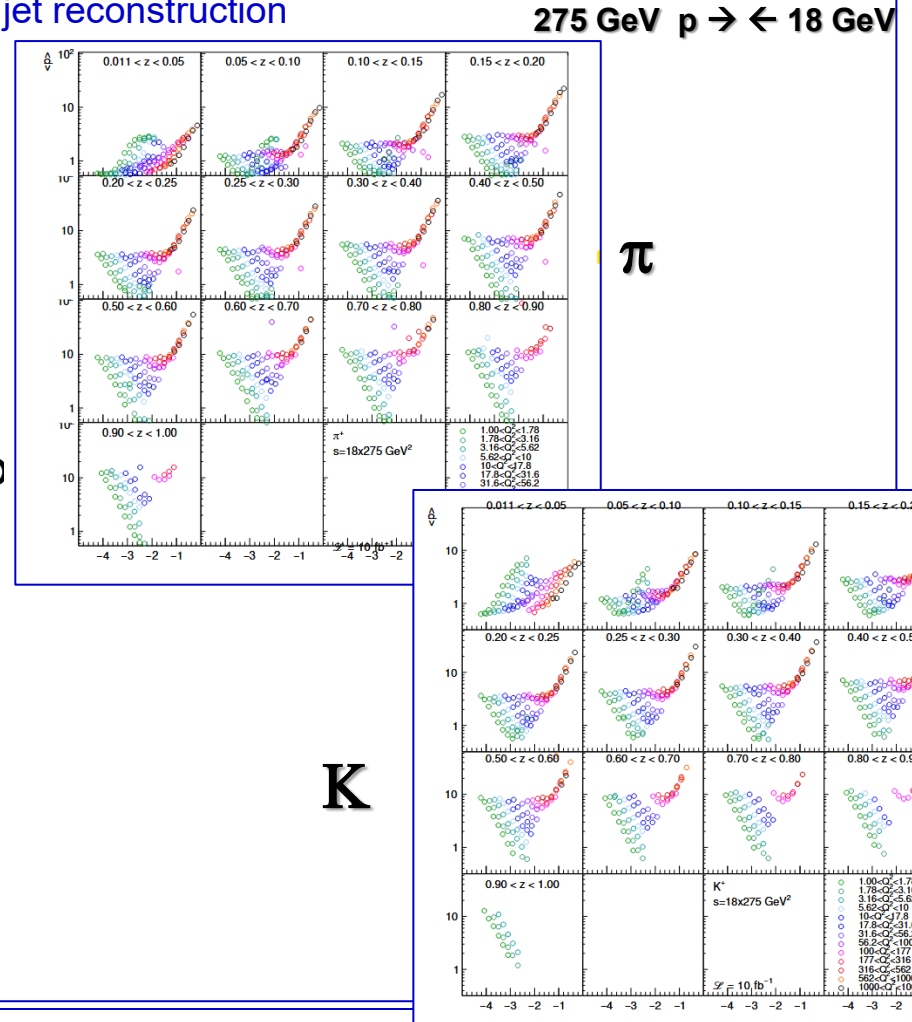

**DIS** Pythia, e+p 18 x 275 GeV

**3  $\sigma$  separation areas**

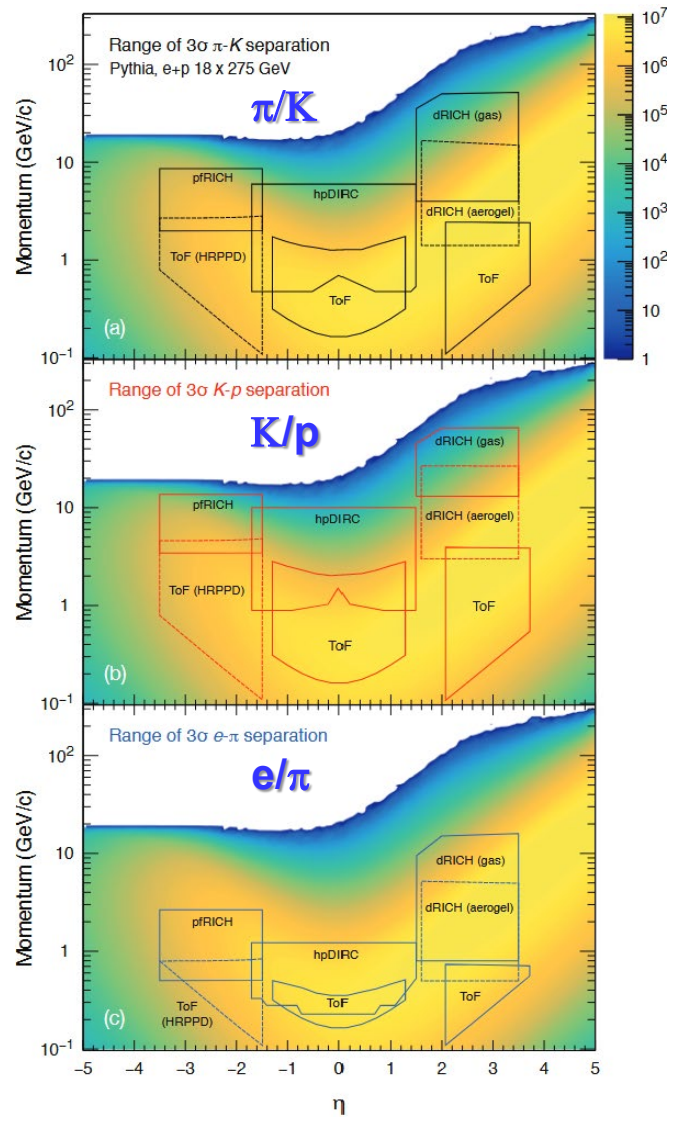
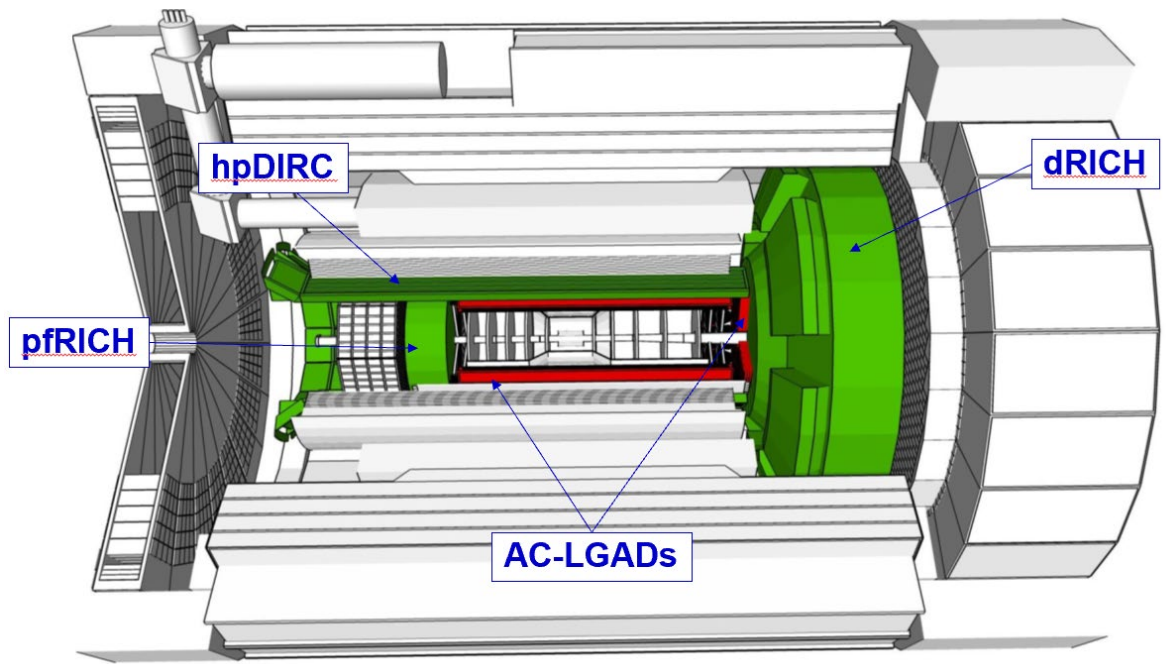

# PID IN ePIC CD

Cherenkov imaging PID in backward endcap:

**proximity focusing RICH (pfRICH)**

The long proximity gap ( $\sim 35$  cm) enhances the resolution

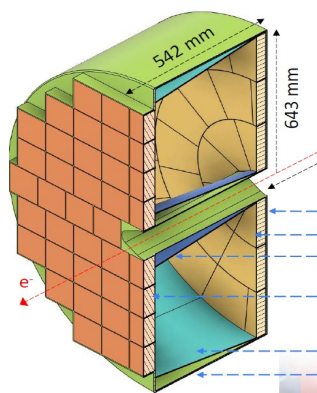

**High performance DIRC (hpDIRC)**

High performance thanks to **focalization** and **fine photosensor pizelization**

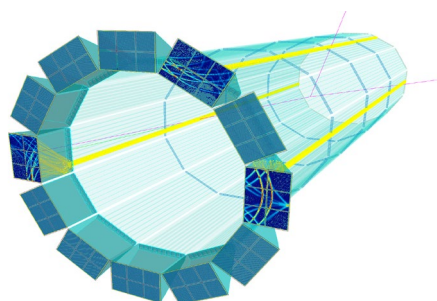

**Dual radiator RICH (dRICH); Areogel and gas**

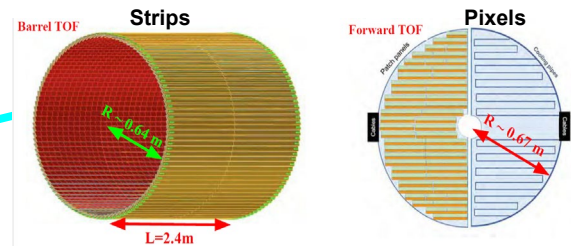
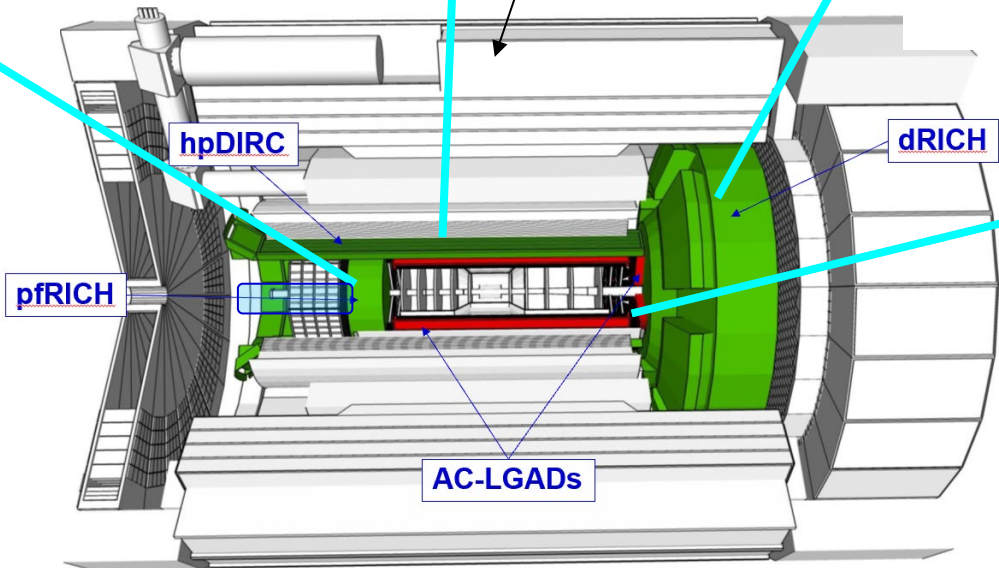
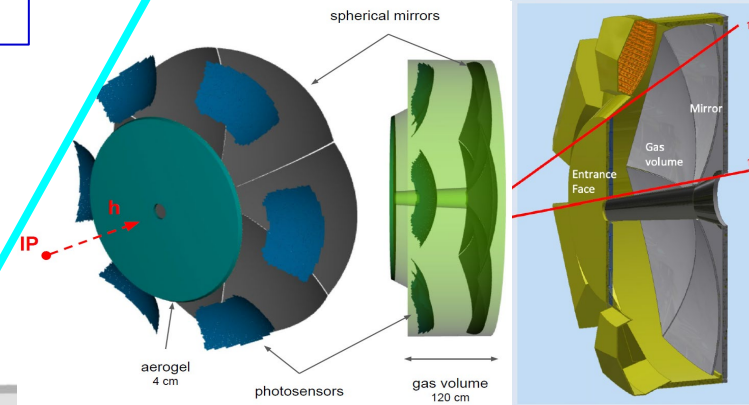

**ToF by AC-LGADs**

Goals for the application in ePIC:

- 30  $\mu\text{m}$  space resolution
- 25-35 ps time resolution

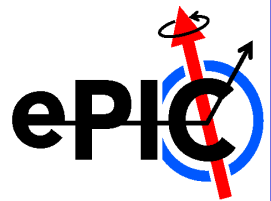

# PHOTOSENSORS for CHERENKOV PID IN ePIC

For pfRICH (option for hpDIRC) :  
**HRPPDs by INCOM**  
 → large-size (12 x 12 cm<sup>2</sup>) MCP-PMTs, pixelized

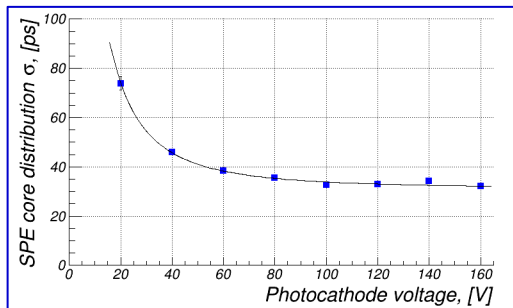
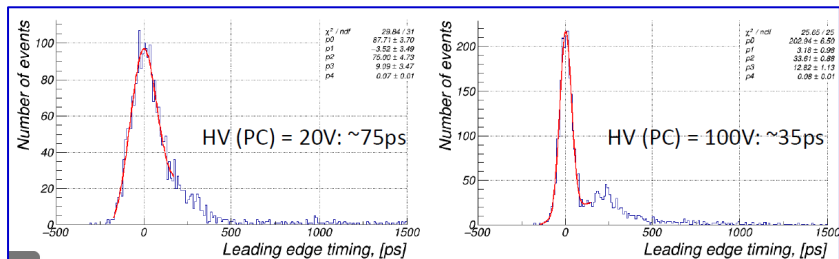
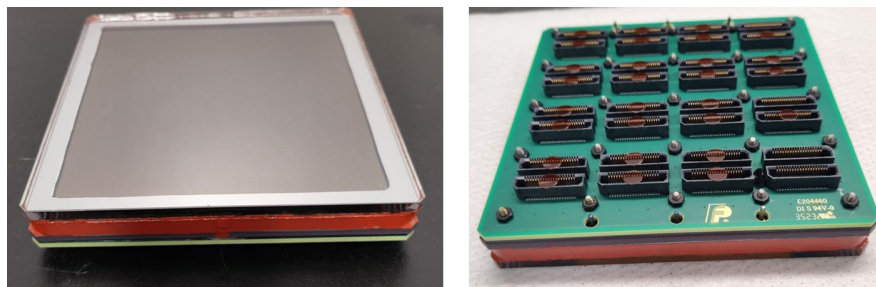

For dRICH : **SiPMs at -30°C**

→ Robust R&D for the validation

Studies of radiation damage on SiPM

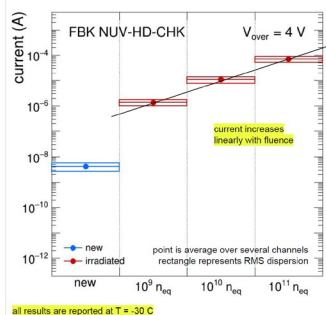

High-temperature annealing recovery  
 "Online" self-induced annealing

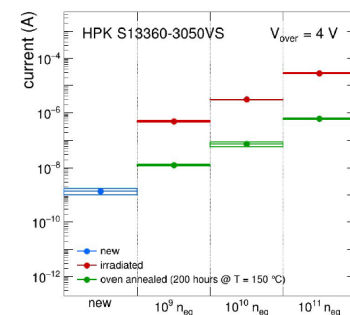

Repeated irradiation/ annealing cycles

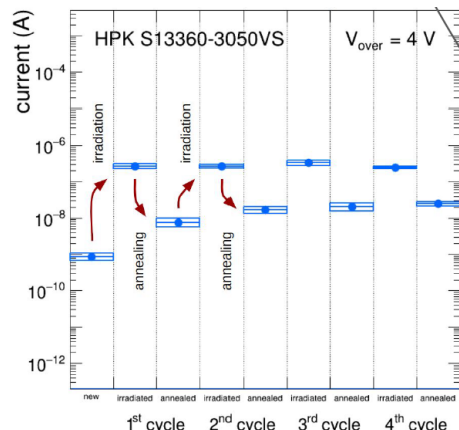

**Ageing model**

Hamamatsu S131360-3050 @ V<sub>over</sub> = 4 V, T = -30 °C

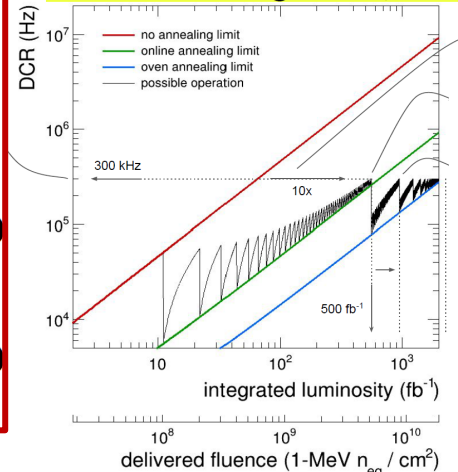

B0 trackers with AC-LGADS  
B0 calorimetry by crystals

RPs and OMDs by  
pixelized AC-LGADS

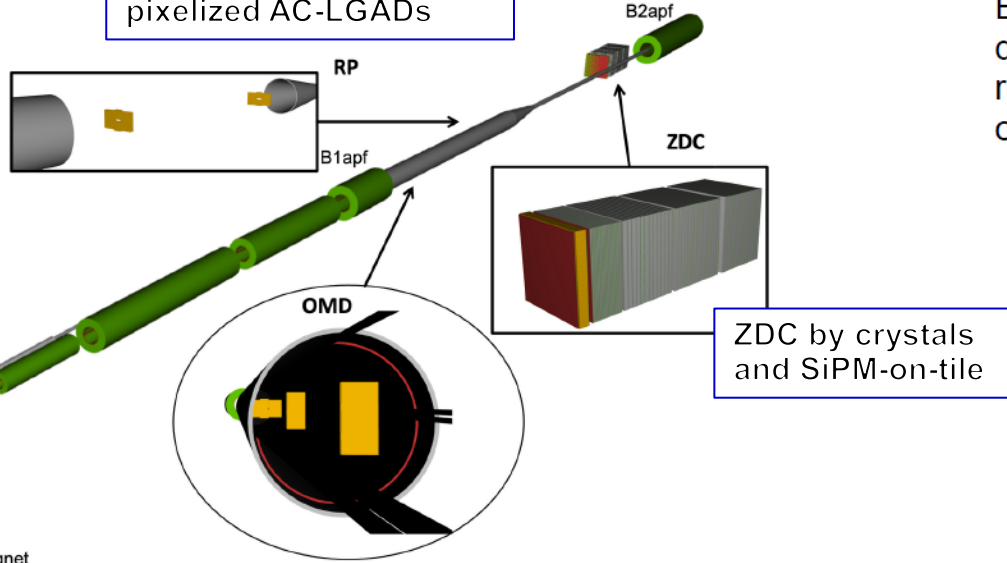
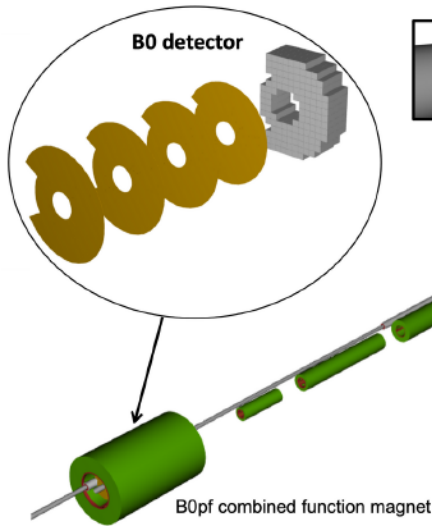

Exclusive / diffractive reactions driving the design of FF area -> reconstruction of particles outside of the central detector acceptance

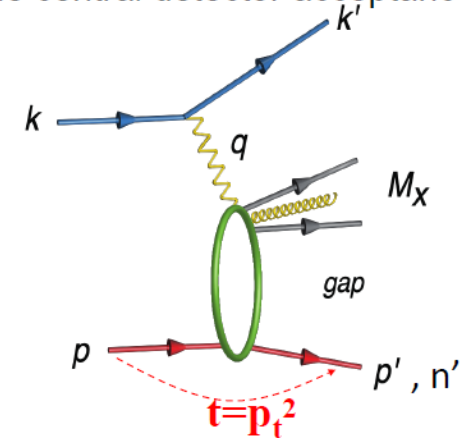

IP

- ✓ protons at wide range of  $p_T^2$
- ✓ protons with different rigidity
- ✓ neutrons and photons

	Particles	Angle [mrad]		Distance from IP
B0-tracker	Charged particles Photons (tagged)	5.5 - 20		ca 6-7 m
Off-momentum	Charged particles	0-5.0	$0.4 < x_L < 0.65$	ca 23-25 m
Roman Pots	Protons Light nuclei	$0^* - 5.0$	$0.6 < x_L < 0.95$	ca 27-30 m
ZDC	Neutrons Photons	0-4.0 (5.5)		ca 35 m

- This area is designed to provide coverage for the low- $Q^2$  events (photoproduction,  $Q^2 < \sim 1 \text{ GeV}^2$ ). Need to measure a scattered electron position/angle and energy
- And luminosity detector (ep  $\rightarrow$  e'p $\gamma$  bremsstrahlung photons)

### Low Q2 taggers

- High rate capability, Fine tracking, pixelization
- Tracking – Timepix4 Hybrid (ASIC+Si tracker) –
- Calorimetry – W/SciFi

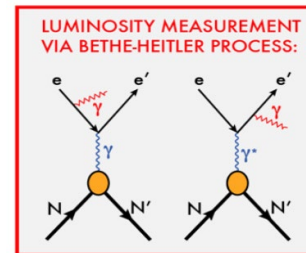
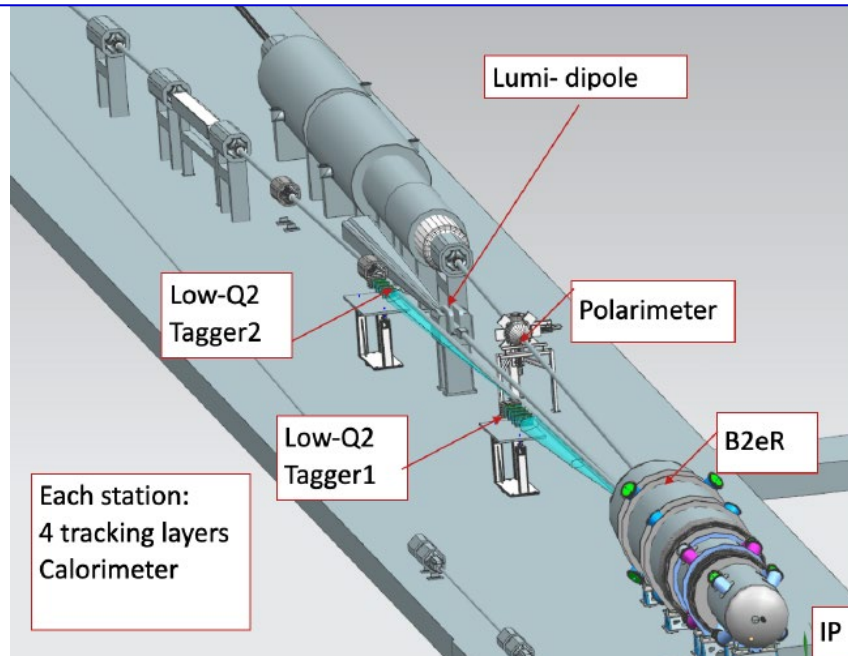

Luminosity – high rate calorimeter - W-SciFi

### LUMINOSITY – pair spectrometers

- TRACKING – AC-LGAD strips
- CALORIMETRY – W-SciFi

## Luminosity monitor and measurement

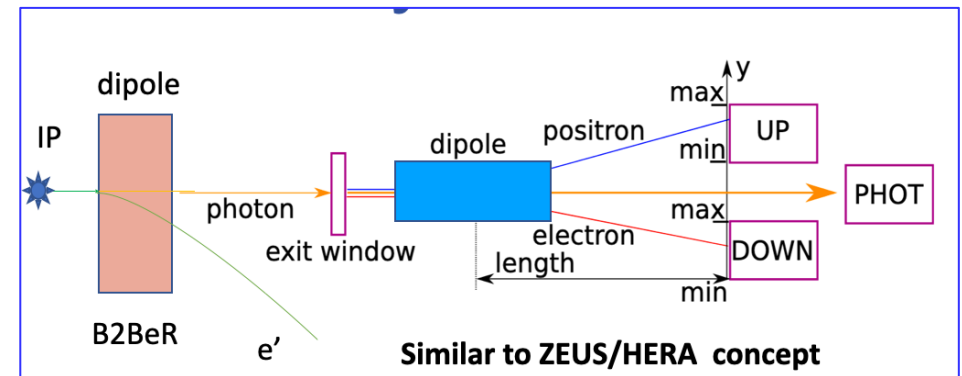

EIC Large Area Sensor (LAS), modification of ITS3 sensor with 5 or 6 RSU forming staves as the basic building elements for the Outer Barrel and the Tracking Disks

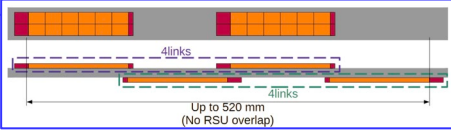

HRPPDs for Cherenkov imaging and Time-of-Flight for pfRICH

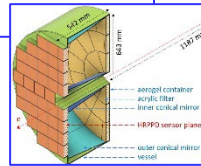

first-time full-size CALICE-like calorimeter in collider experiment in the forward HCal

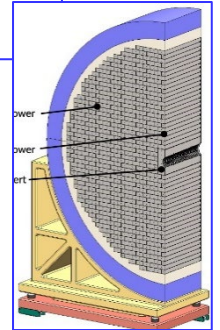

planar double amplification (GEM &  $\mu$ RWELL) modules & 2D-strip readout for the MPGD outer trackers and disks

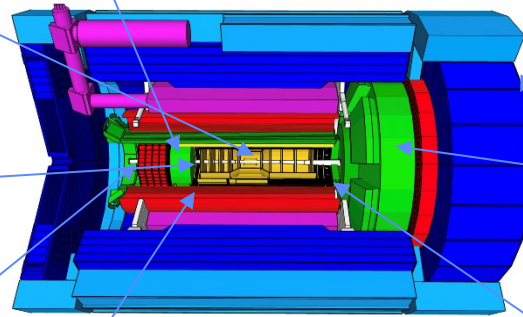
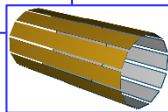

First use of SiPMs as Photosensors in a RICH for the dRICH

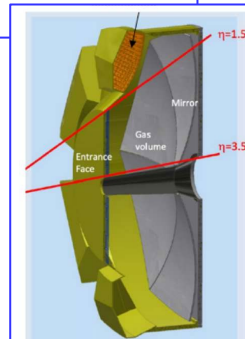

SiPM as Photosensors in crystal calorimetry for backward endcap ECal

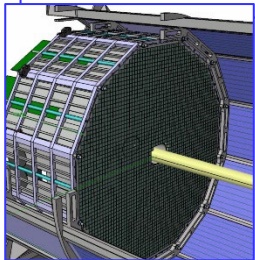

Use of ASTROPIX in Calorimetry for the imaging barrel ECal

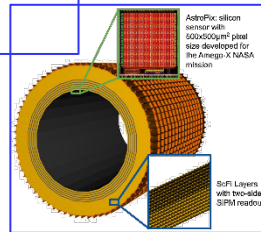

First time use of AC-LGAD in a collider detector for barrel and forward endcap ToF

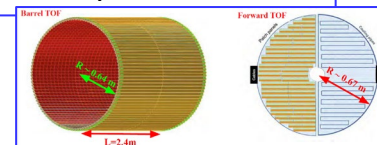

The EIC is a unique project, the world only one approved for the ultimate understanding of **QCD**

Most likely, the only novel high energy collider in the next 15-20 years

- The EIC project is approved and progressing toward full realization
- The ePIC Collaboration for the project detector is working and highly committed to the detector and the physics scope
- The ePIC detector design is fully dictated by the physics scope
  - A number of established and novel technologies required to match this scope
- *Exciting perspectives in front of us designing, building, operating ePIC and progressing in physics with our detector*
  - *The time to join us is now!*

THANK YOU

# THE ePIC FAR FORWARD DETECTORS

B0 trackers with AC-LGADS  
 B0 calorimetry by crystals

- TRACKING - Synergies with forward ToF
- CALORIMETRY - Synergy with backward ECal and ZDC

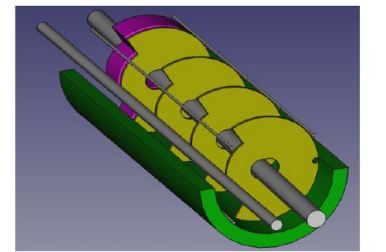

B0 Trackers + Calorimeter

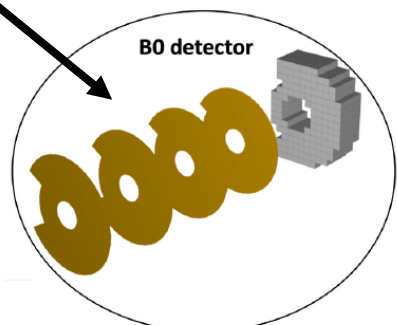

B0 detector

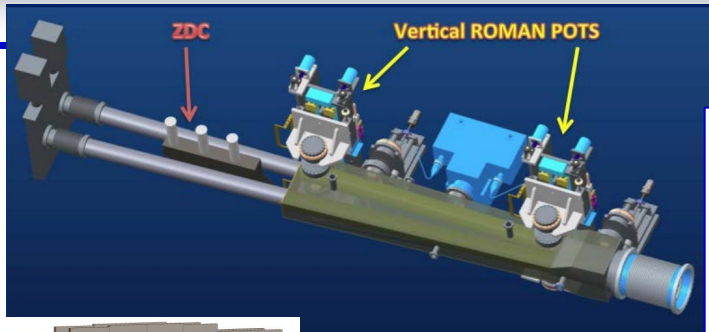

ZDC

Vertical ROMAN POTS

RP and OMDs by pixelized AC-LGADS

- Synergies with forward ToF

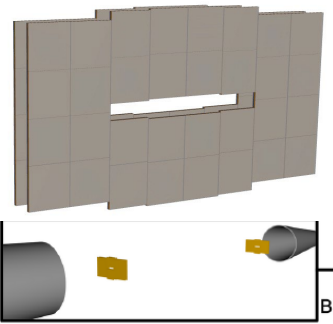

B1apf

B2apf

ZDC

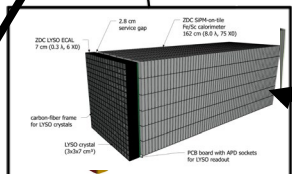

ZDC by crystals and SiPM-on-tile

- ECal - Synergy with backward ECal and B0 calorimetry
- HCal - Synergies with forward ECal insert



p/A beam

B0pf combined function magnet

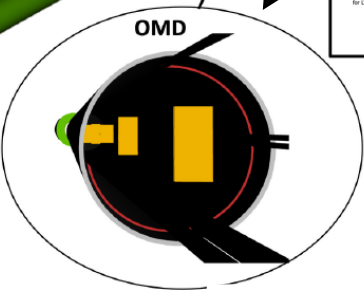

OMD

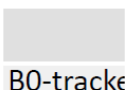

B0-tracker

## Low Q2 taggers

- High rate capability
- Fine tracking pixelization

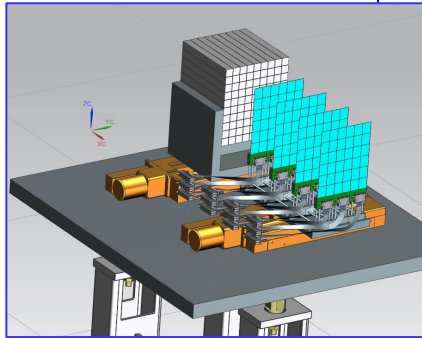

- Tracking – Timepix4 Hybrid (ASIC+Si tracker) – FRONTIER APPLICATION
- Calorimetry – SciFi's
- Timepix4 – wide experience accumulated with the different timepix versions

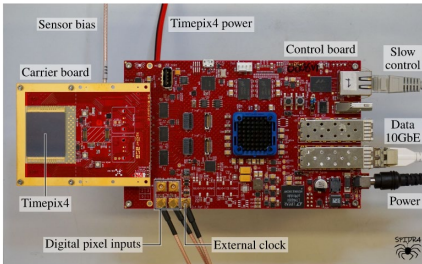

- CALORIMETRY - Synergy with forward ECal

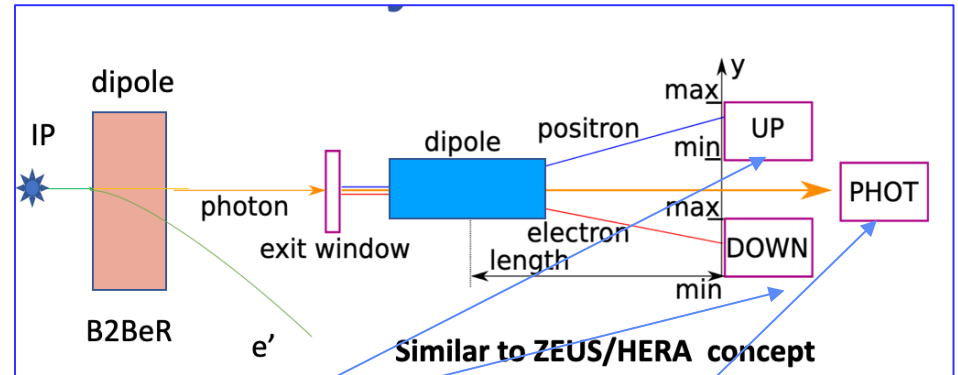

## LUMINOSITY – pair spectrometers

- TRACKING – AC-LGAD strips  
*Synergies with barrel ToF*
- CALORIMETRY – W-SciFi - *Synergy with forward ECal*

## Luminosity – high rate calorimeter – CONSOLIDATED TECHNOLOGIES

- W-SciFi – *synergies with forward ECal*
- Cu-QFi

