

# Production of Vessel and Mirrors for the pfRICH Detector at the Electron-Ion-Collider

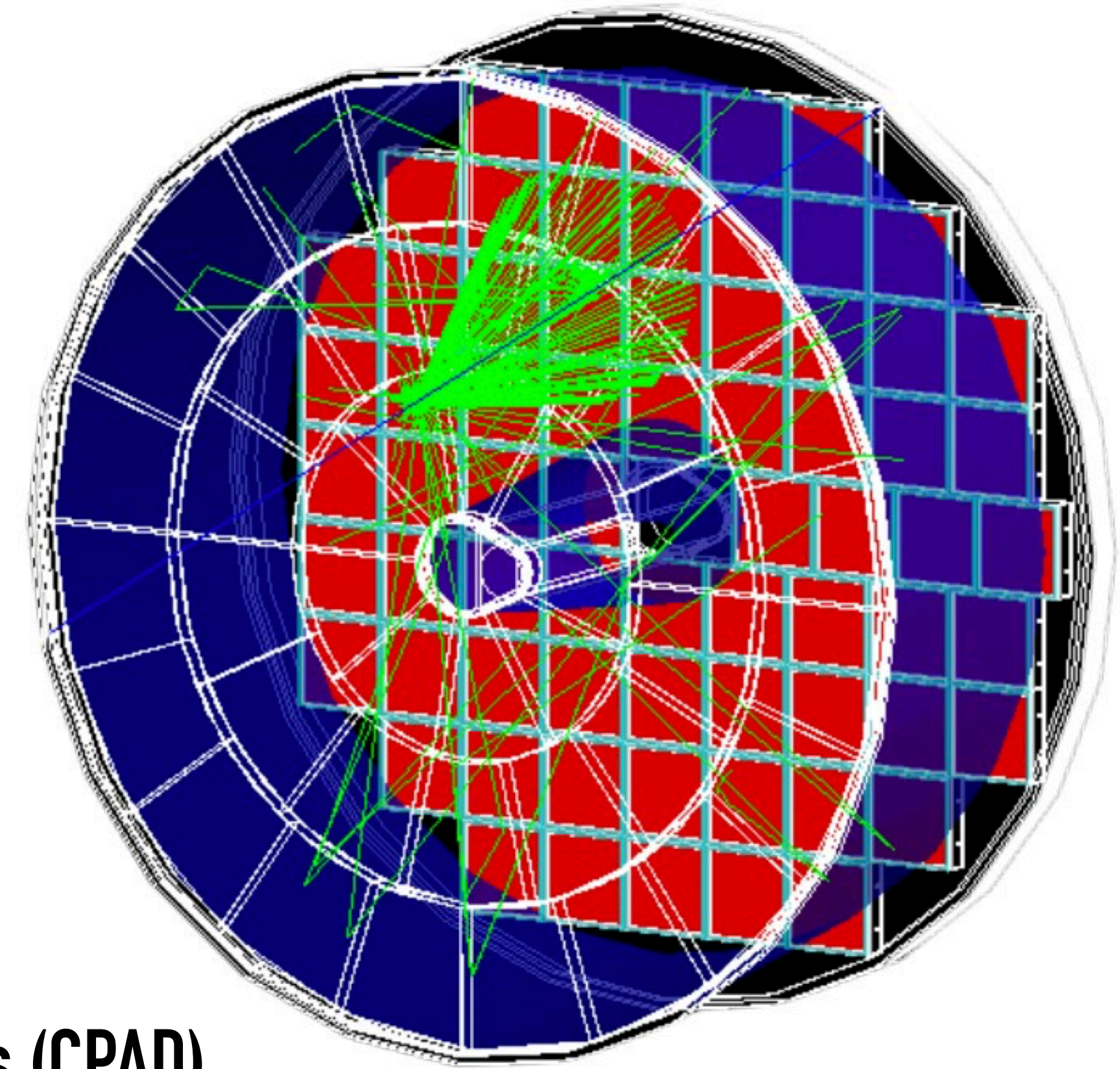

C-J. Naïm

Coordinating Panel on Advanced Detectors (CPAD)

October, 9, 2025



# The ePIC detector at the EIC

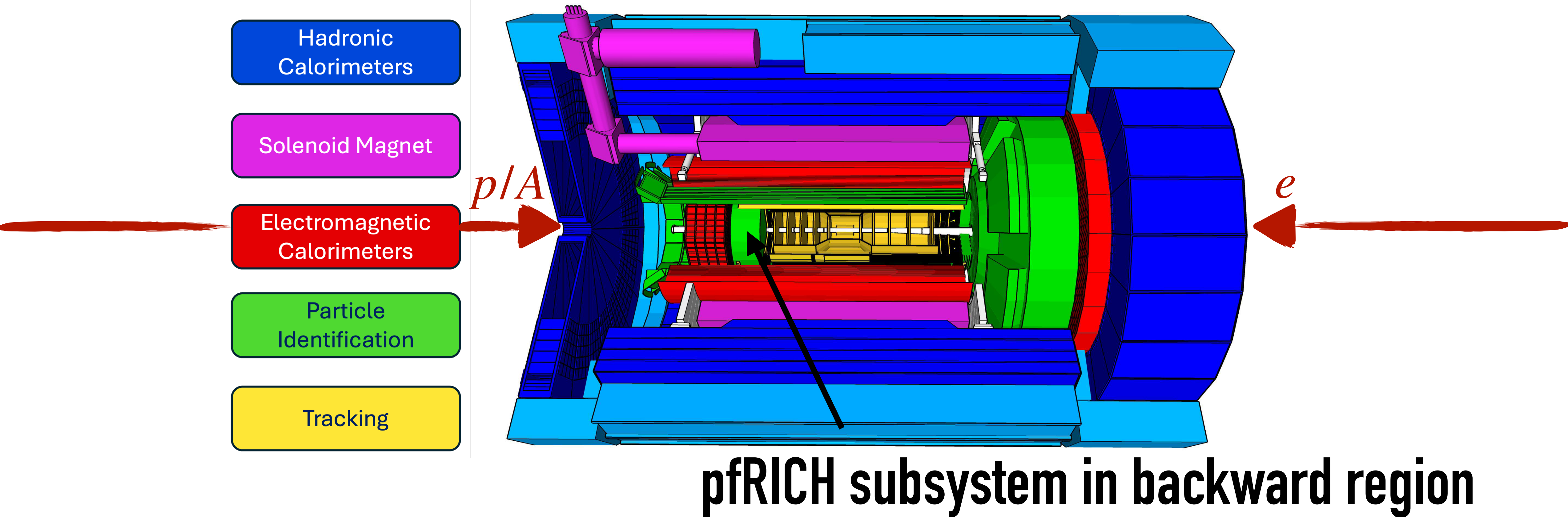

- A compact central detector with several subsystems
- Hermetic coverage:  $-3.5 < \eta < 3.5$  (tracking, calorimetry, **particle identification**)

# Physics Motivations at the EIC

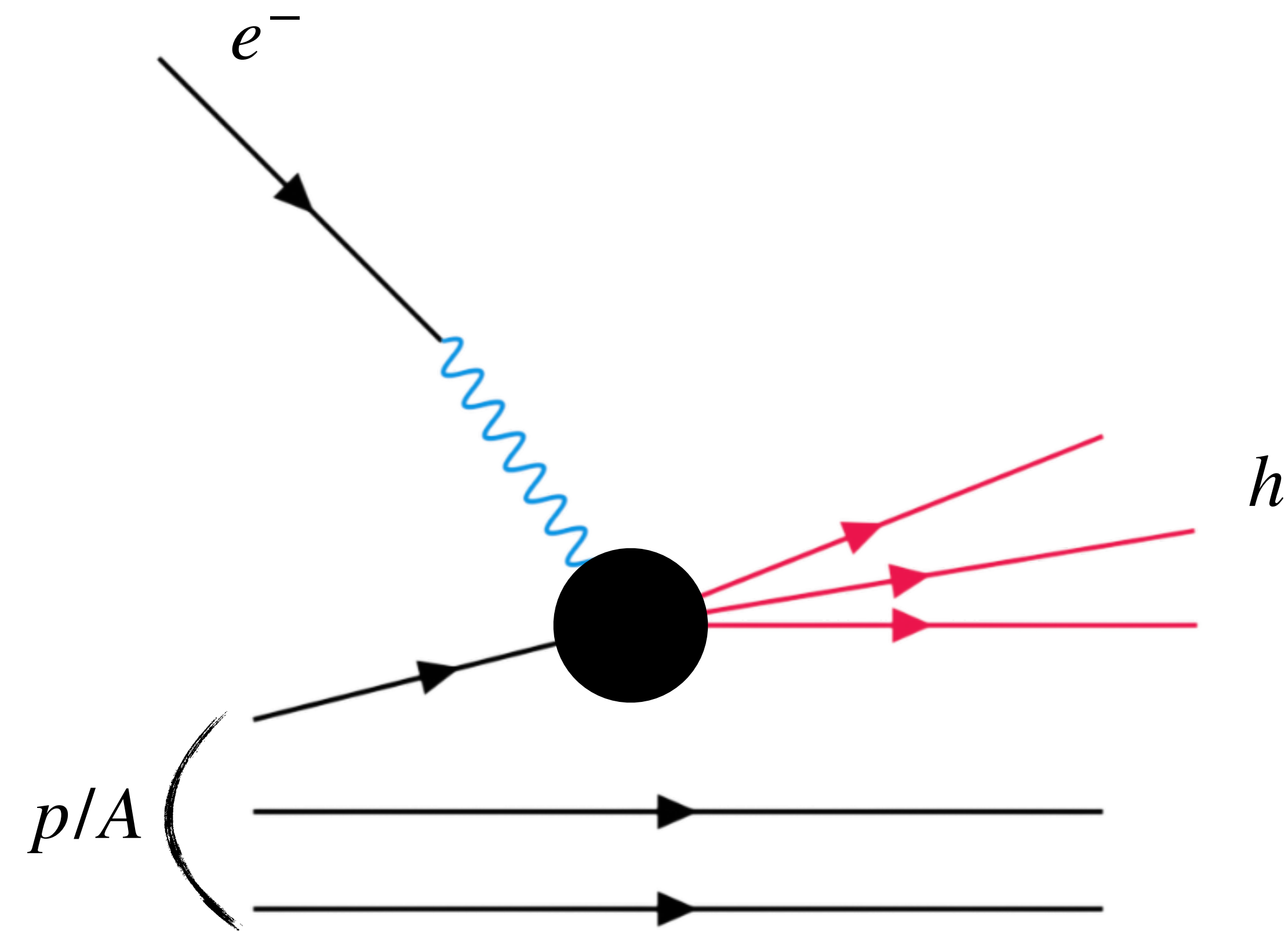

- **Semi-Inclusive Deep Inelastic Scattering**
- **Production of hadrons in final-state**
- Provide information on:
  - the *fragmentation process (hadronization)*
  - the *hadronic structure*

**Particle Identification detectors are crucial**

# The pfRICH Concept

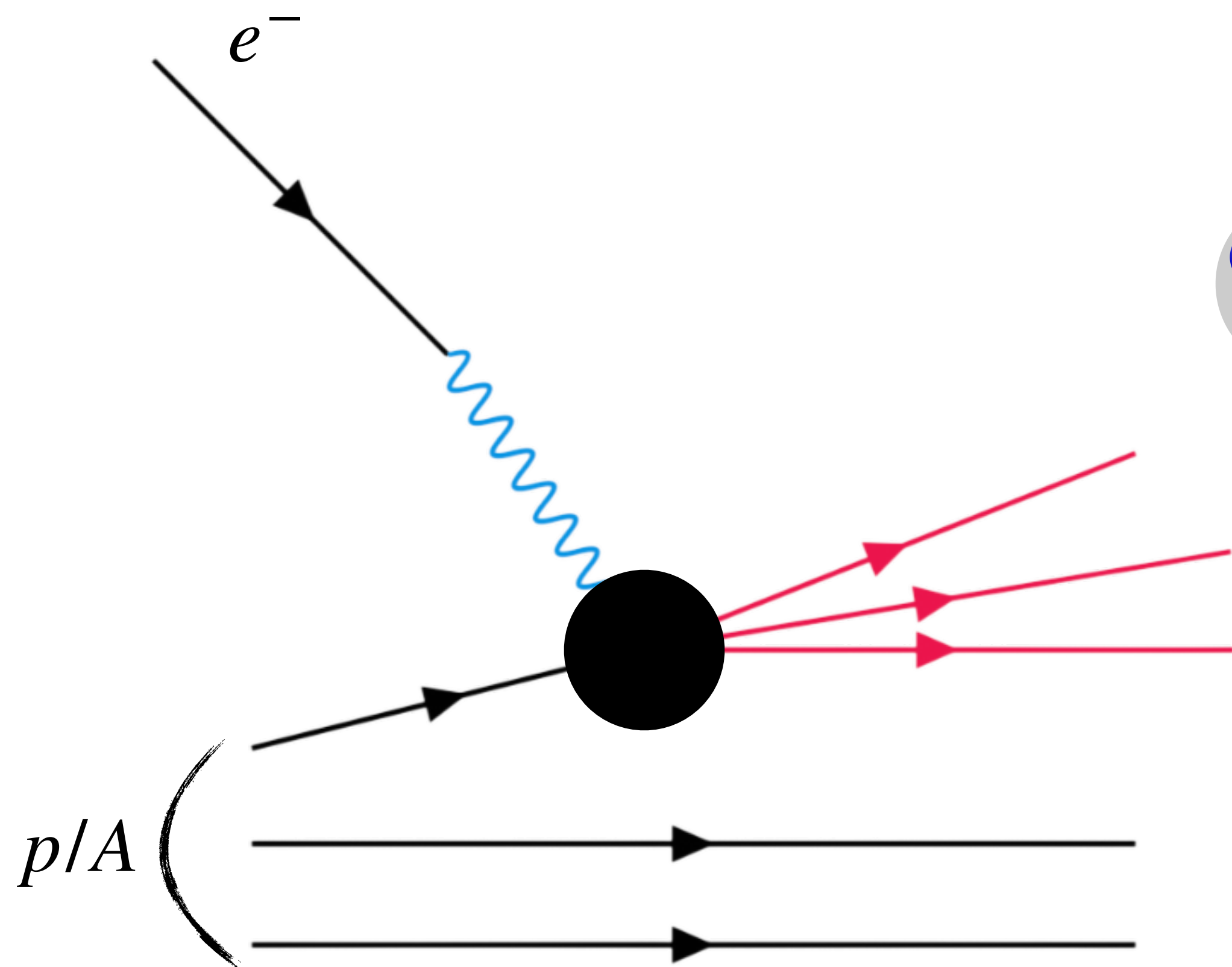

The pfRICH will provide  $> 3\sigma$   $\pi/K$  separations for momentum up to 7 GeV/c for  $-3.5 < \eta < -1.5$

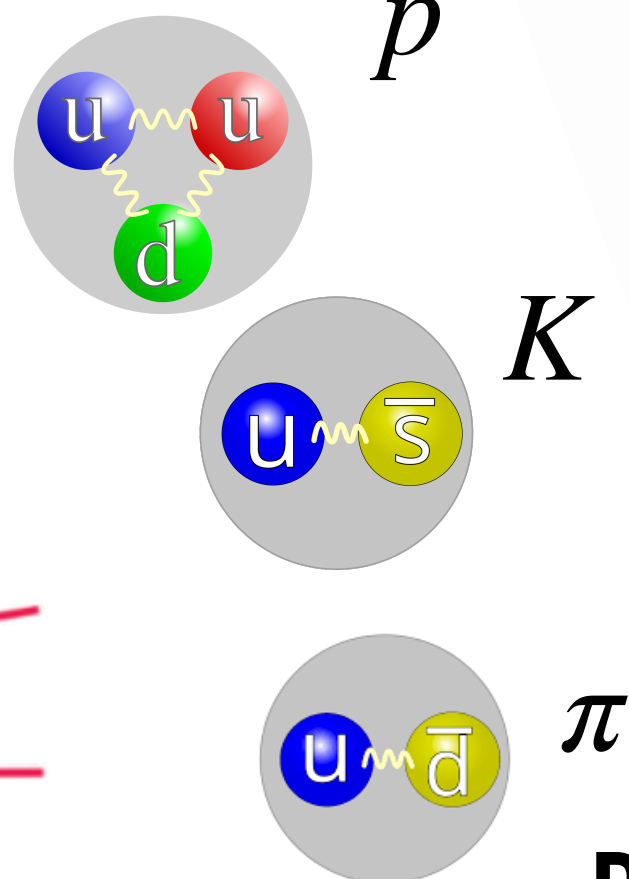

## Particle Identification

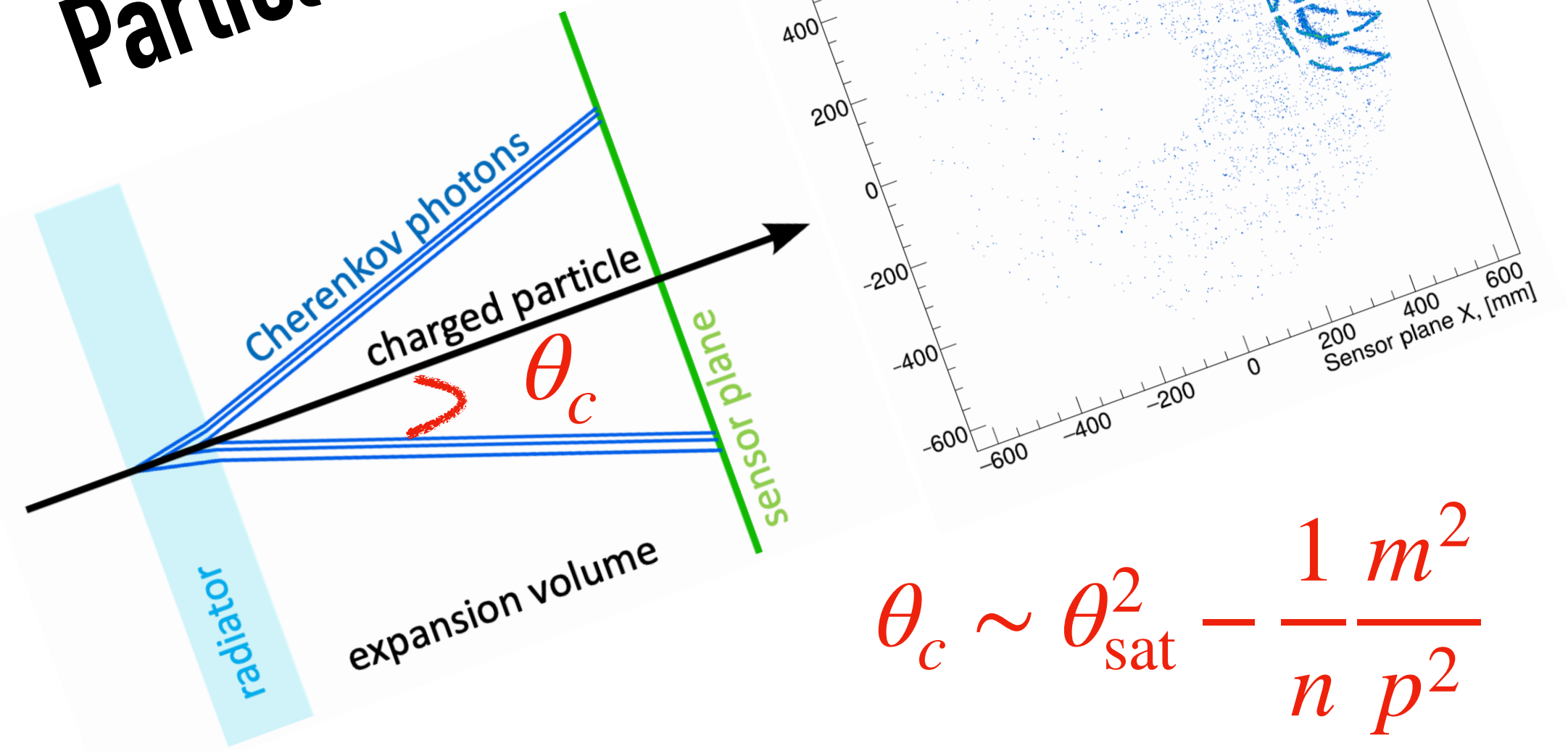

$$\theta_c \sim \theta_{\text{sat}}^2 - \frac{1}{n} \frac{m^2}{p^2}$$

## Detection Principle

- Charged particle  $\rightarrow$  emits Cherenkov photons at angle  $\theta_c$
- Photons project onto photodetectors  $\rightarrow$  form a **ring**  
 $\rightarrow$  Ring radius  $\propto \tan \theta_c$
- Measuring ring size  $\rightarrow$  deduce  $\theta_c \rightarrow$  **particle mass**

# The pfRICH Design Summary

## Vessel

- Lightweight structure
- Reinforced carbon fiber and 3D printed materials
- Filled with nitrogen

## HRPPD photosensors

- 120 mm size
- Tiled with a 3.0 mm gap
- 68 sensors total

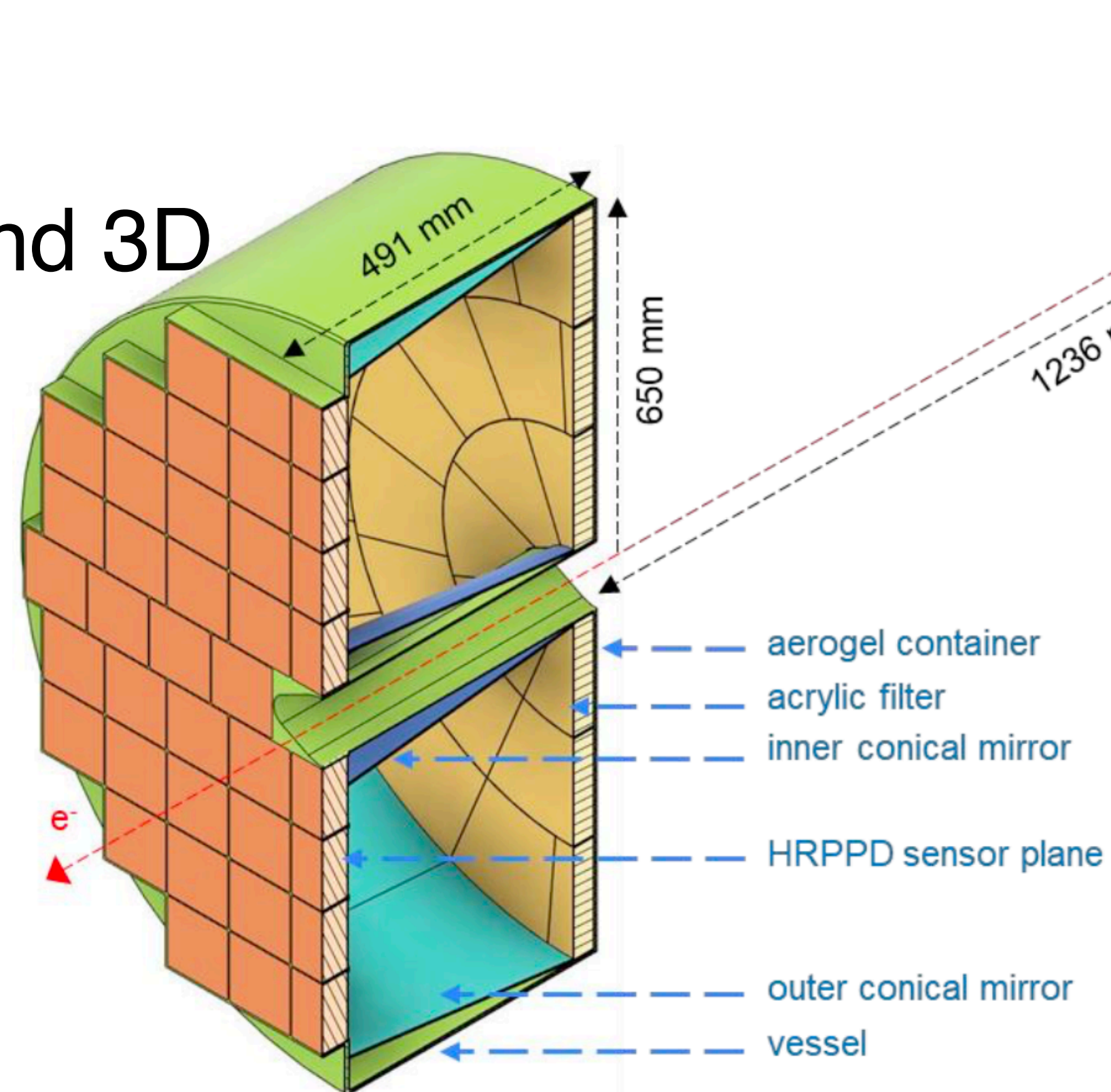

## Mirrors

- Cylindrical and conical geometries
- Large acceptance
- High reflectivity

## Aerogel

- Three radial bands
- Opaque dividers
- 2.5 cm thick, 42 tiles total

# An International Task Force



Stony Brook  
University

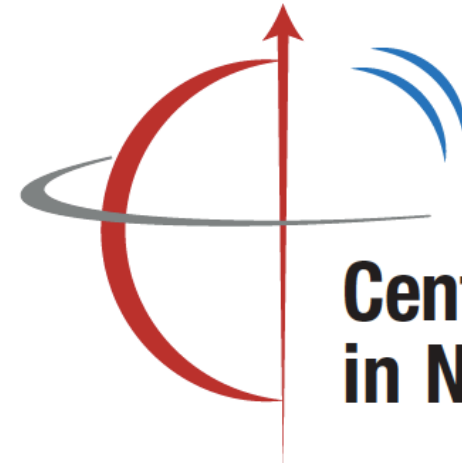

Center for Frontiers  
in Nuclear Science



千葉大学  
CHIBA UNIVERSITY

*University of Ljubljana*



pfRICH

Duke  
UNIVERSITY



Yale



Brookhaven  
National Laboratory

# Vessel Components and Fabrication

## Vessel consists of

- **Cylindrical body** (Stony Brook)
  - Carbon-fiber sandwich structure  
→ *lightweight, gas- and light-tight*
- **Reinforcing end-rings** (Purdue)
  - Machined carbon-fiber end-rings  
→ *stability & sensor/aerogel mounting*
- **Sensor plane** (Purdue)
- **Aerogel wall** (Purdue)

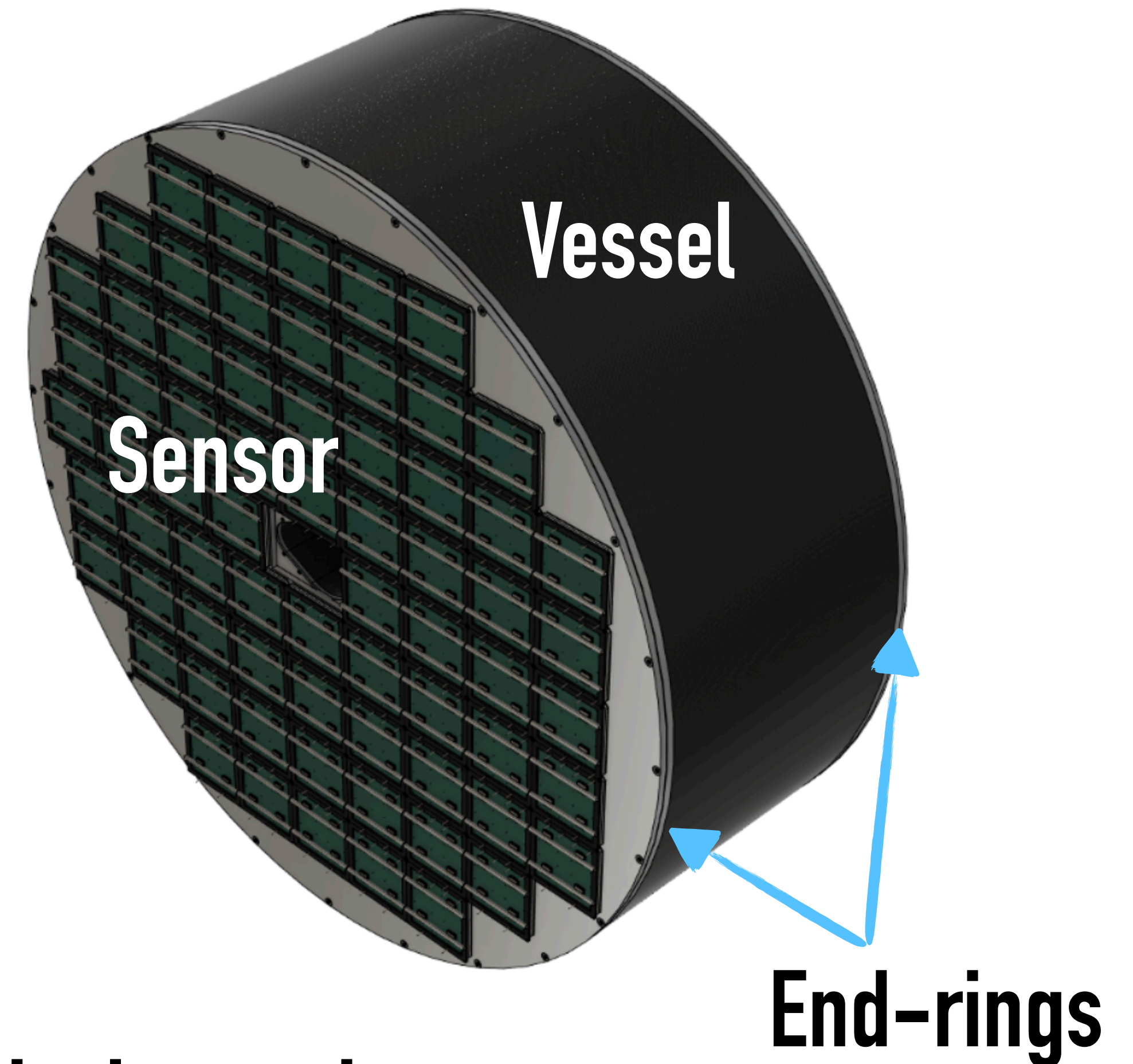

**Objective: build a cylindrical vessel**

# Mandrel Assembly for the Vessel

80/20 structure

Foam milling

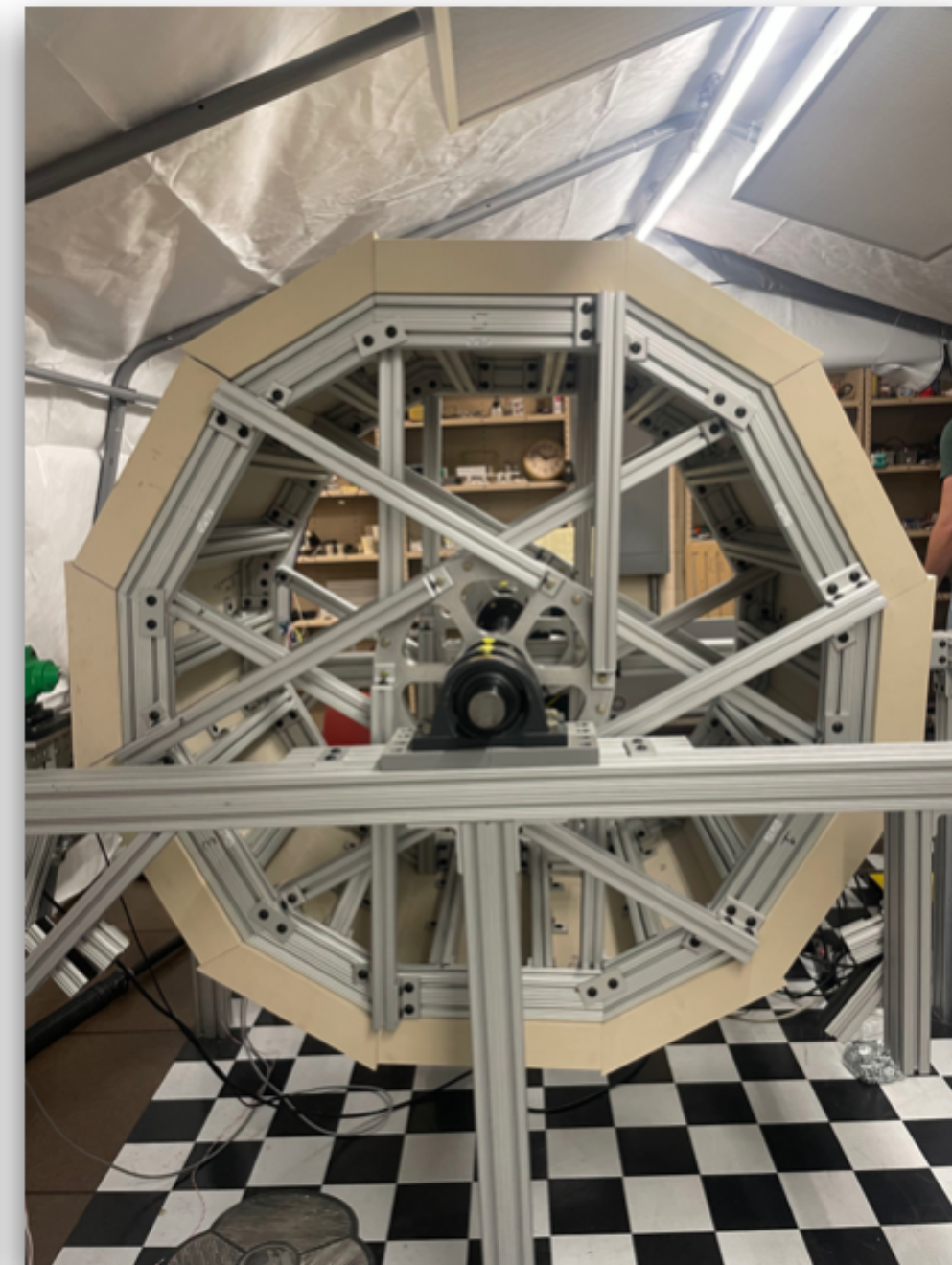
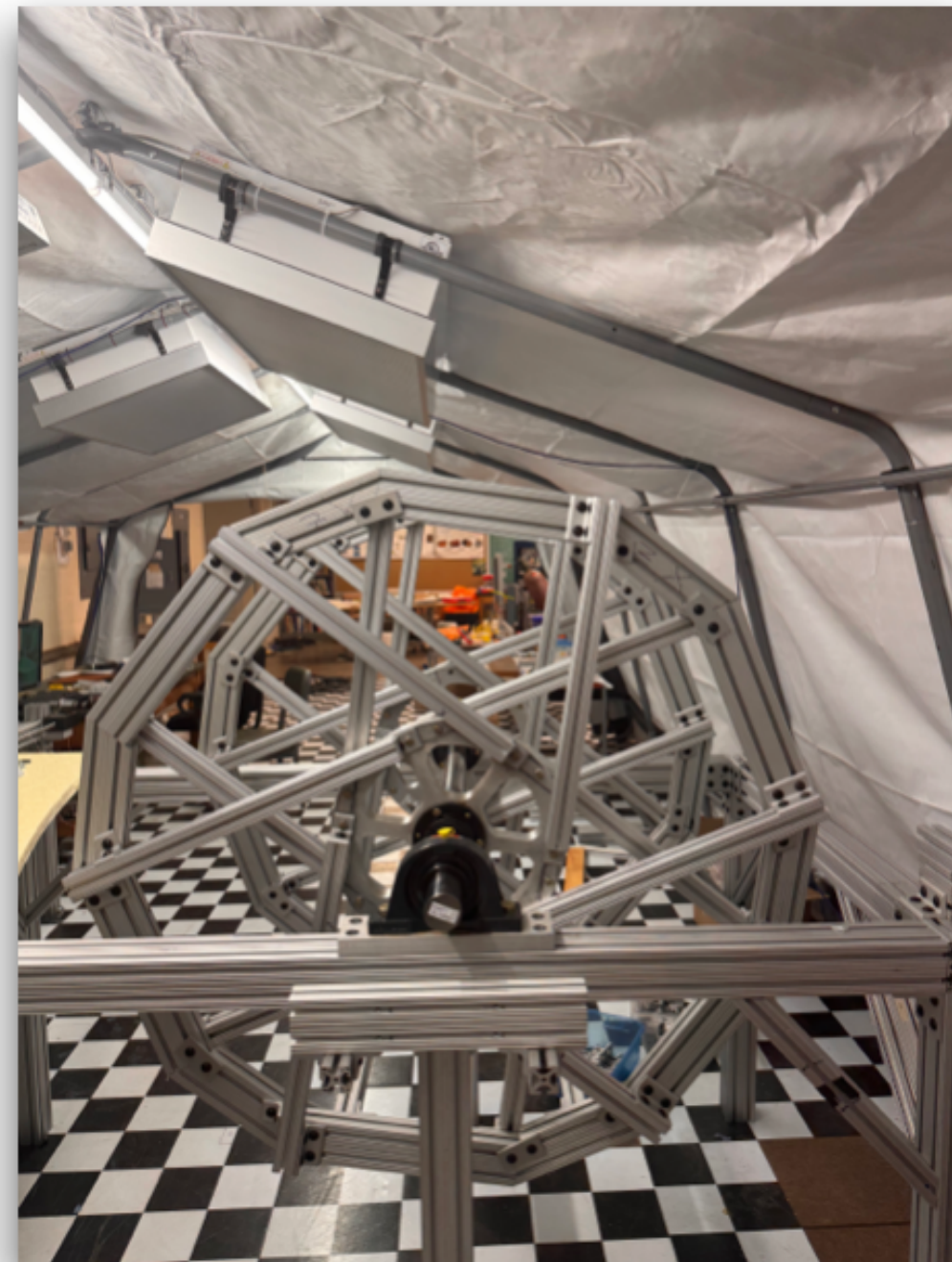

Foam installation

# Mandrel Machining for the Vessel

## Foam Machining System

- Cutting uses a lathe-like setup with a rotating bit, driven by 3 motors
  - **Milling - Linear - Rotary** motors
- 1. End mill mounted on a motorized micrometer stage → *precise depth control*
- 2. Lead screw motor moves the stage horizontally
- 3. Mandrel motor rotates the foam

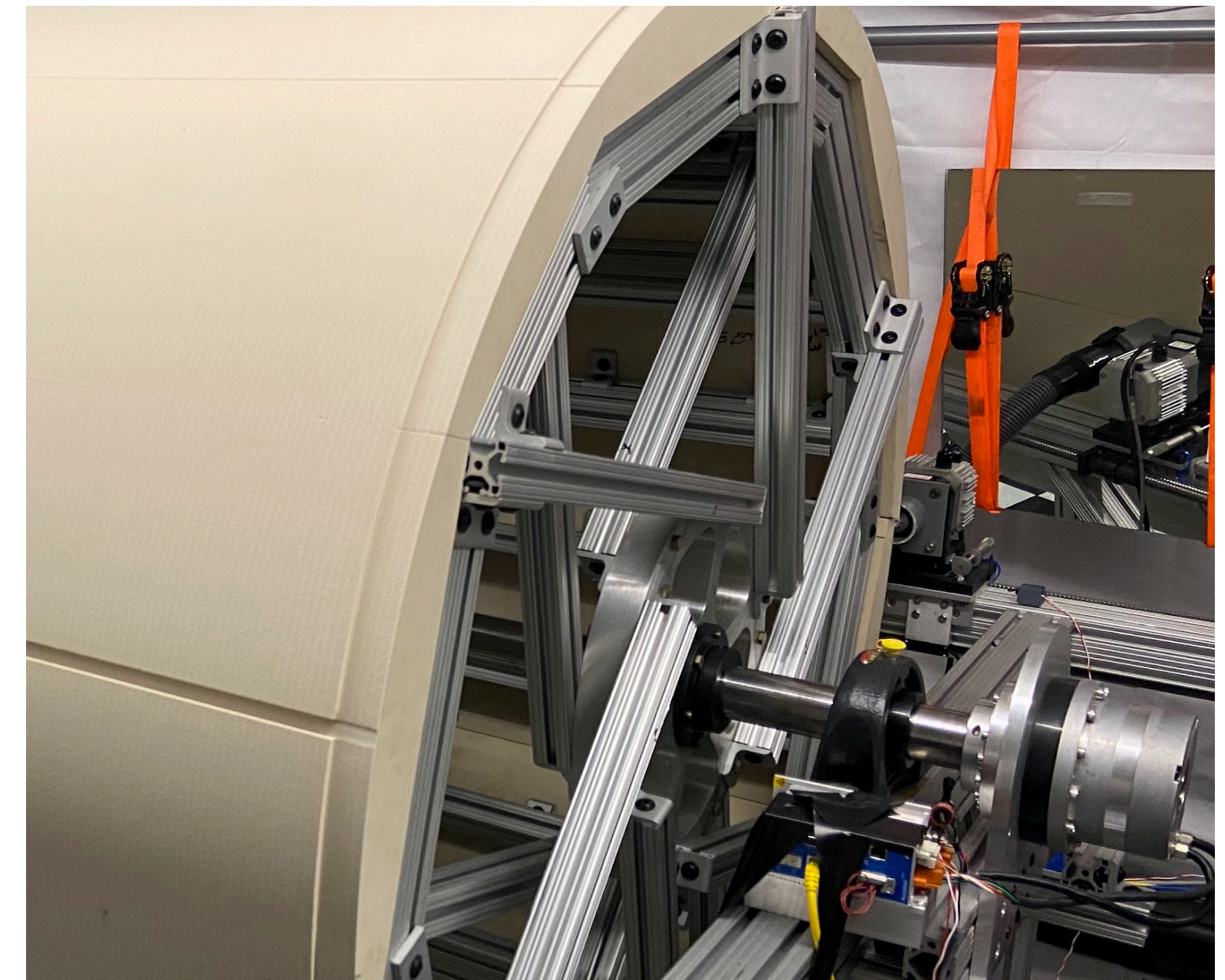
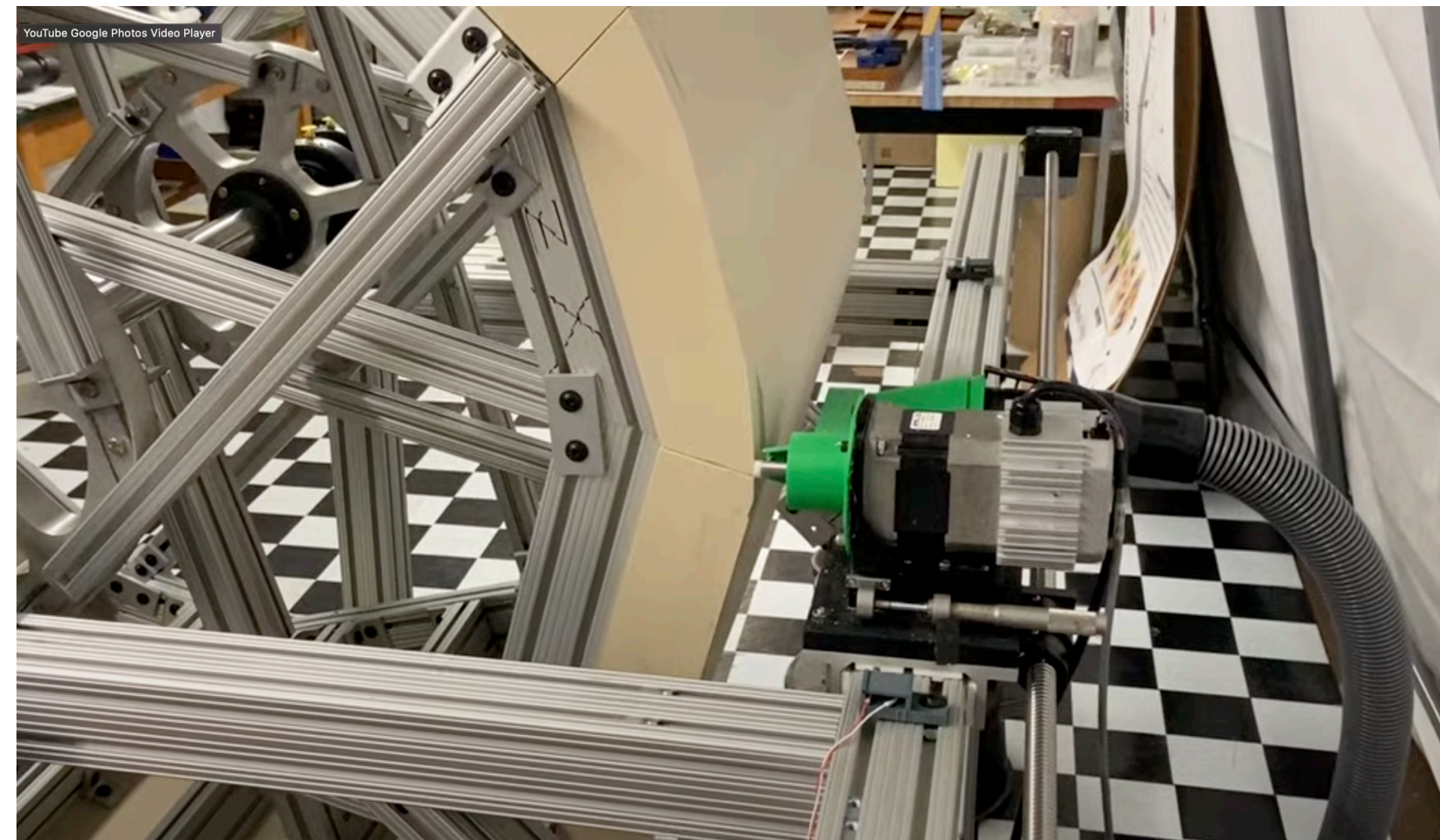

# Mandrel Metrology

## Digital microscope

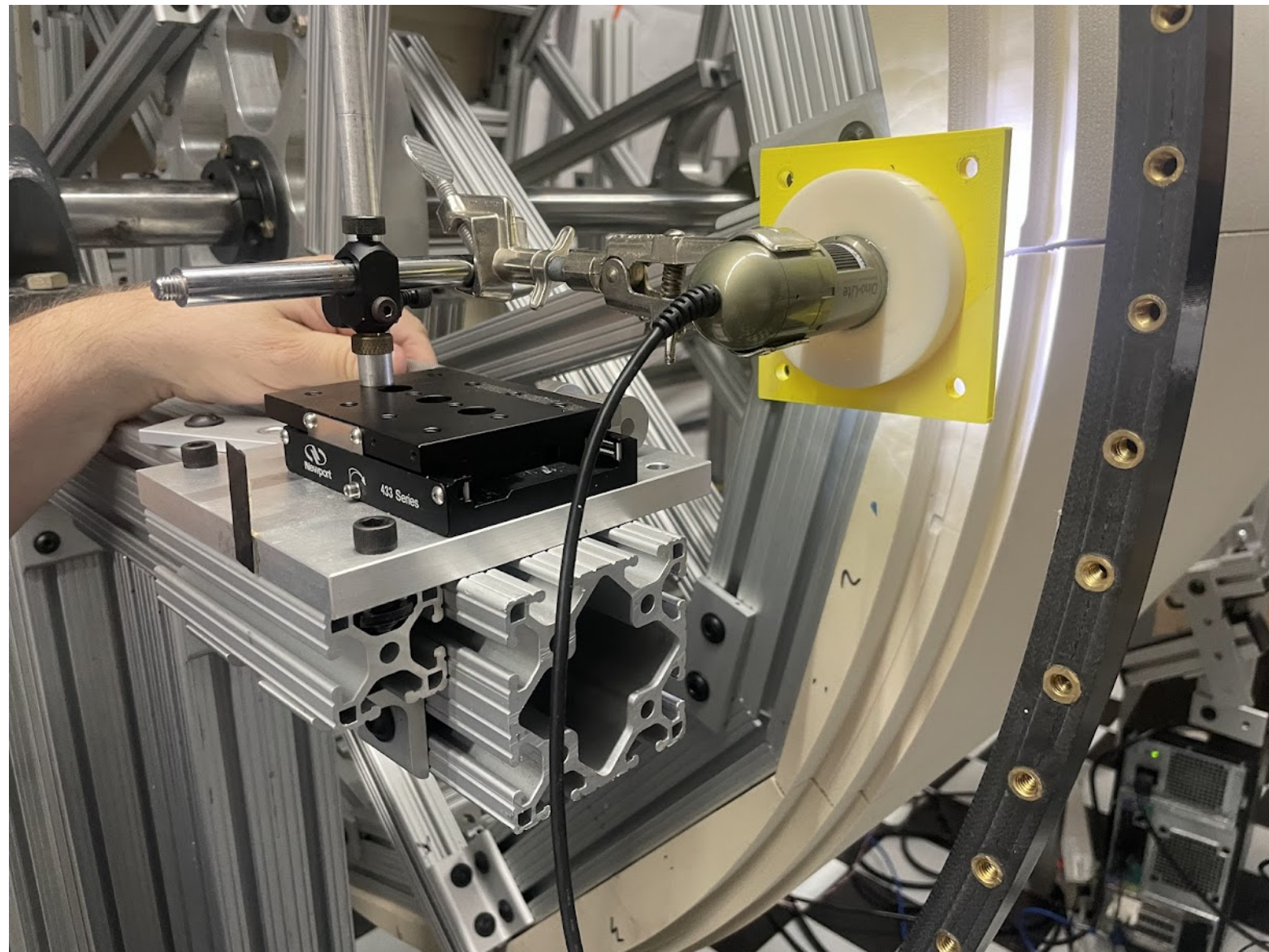

- Checks uniformity  
→ of  $z$  in  $r$  and  $\phi$

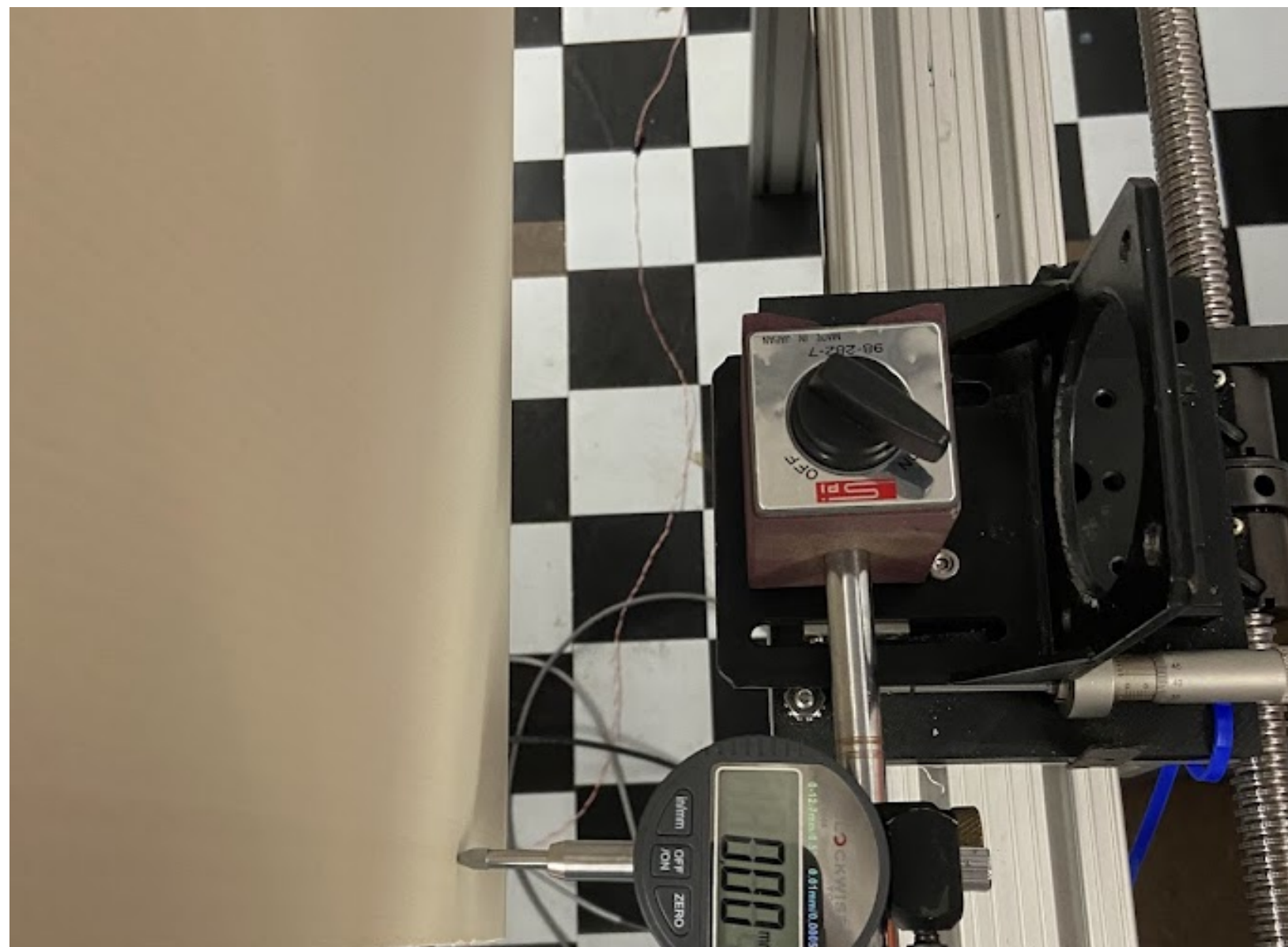

- Checks uniformity  
→ of  $r$  in  $\phi$  at the edges

## Depth scan

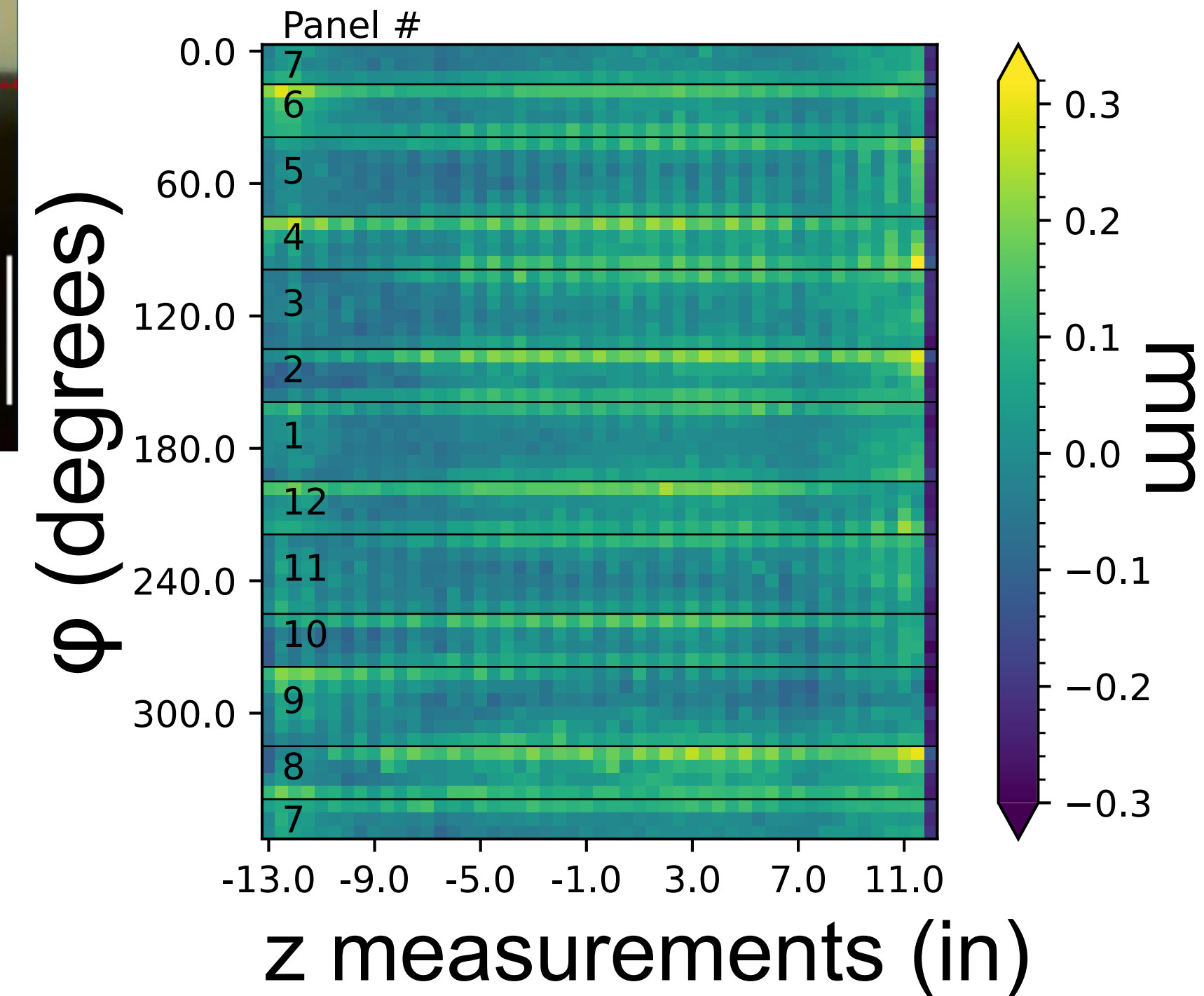

→ Precision:  $\pm 0.1$  mm

# pfRICH Vessel Assembly

- Foam mandrel not part of pfRICH → used only as mold for cylinder shaping
- Outer vessel: sandwich of **carbon-fiber composite plastic** with **aramid honeycomb core**
- End-rings aligned in  $z$  and  $\phi$  with digital microscope on cutter stage



# pfRICH Vessel Assembly

- The outer carbon-fiber sheet is **bonded** to the honeycomb and end-rings
- End rings **aligned** in  $z$  and  $\phi$  with digital microscope on cutter stage

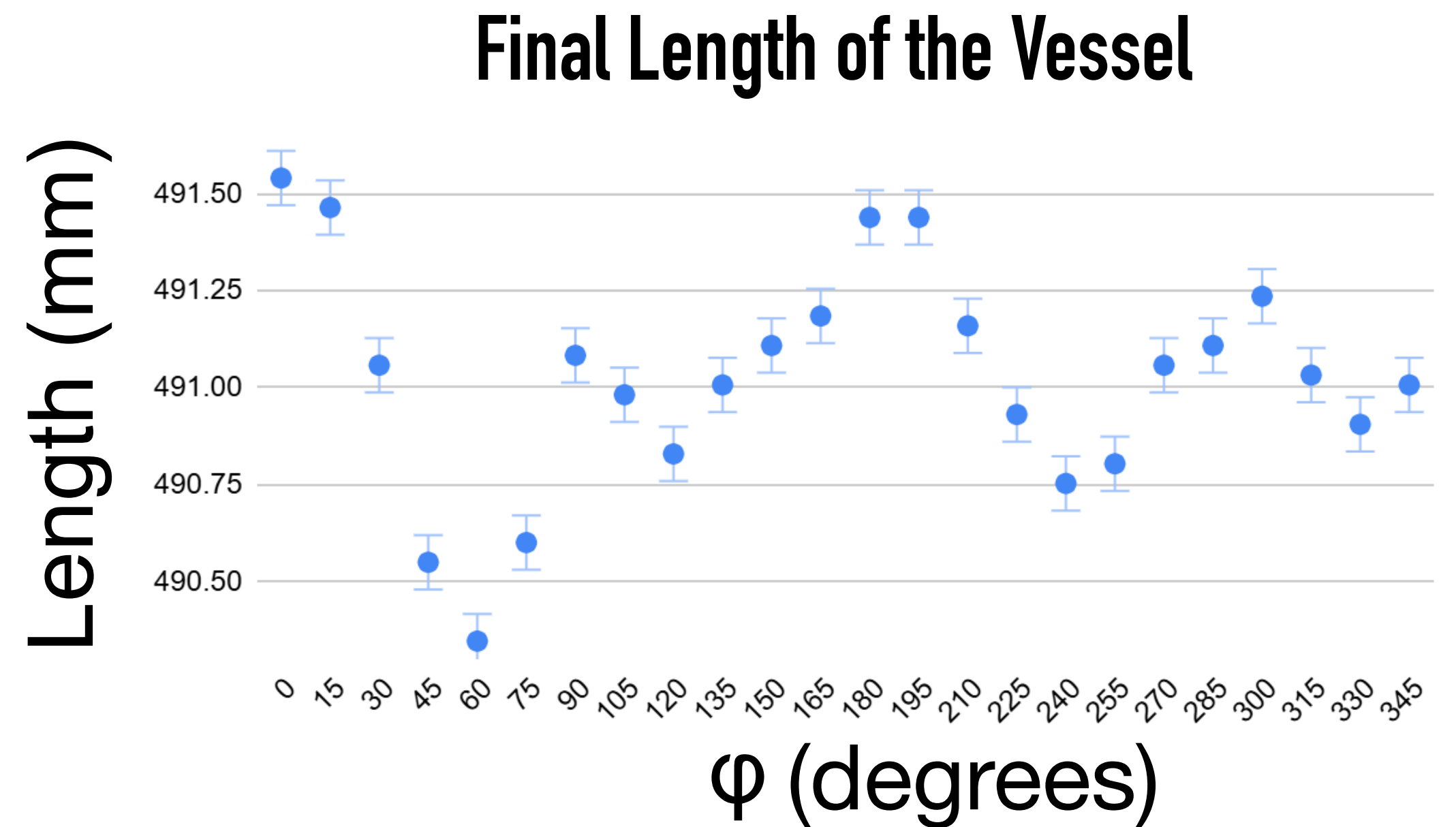
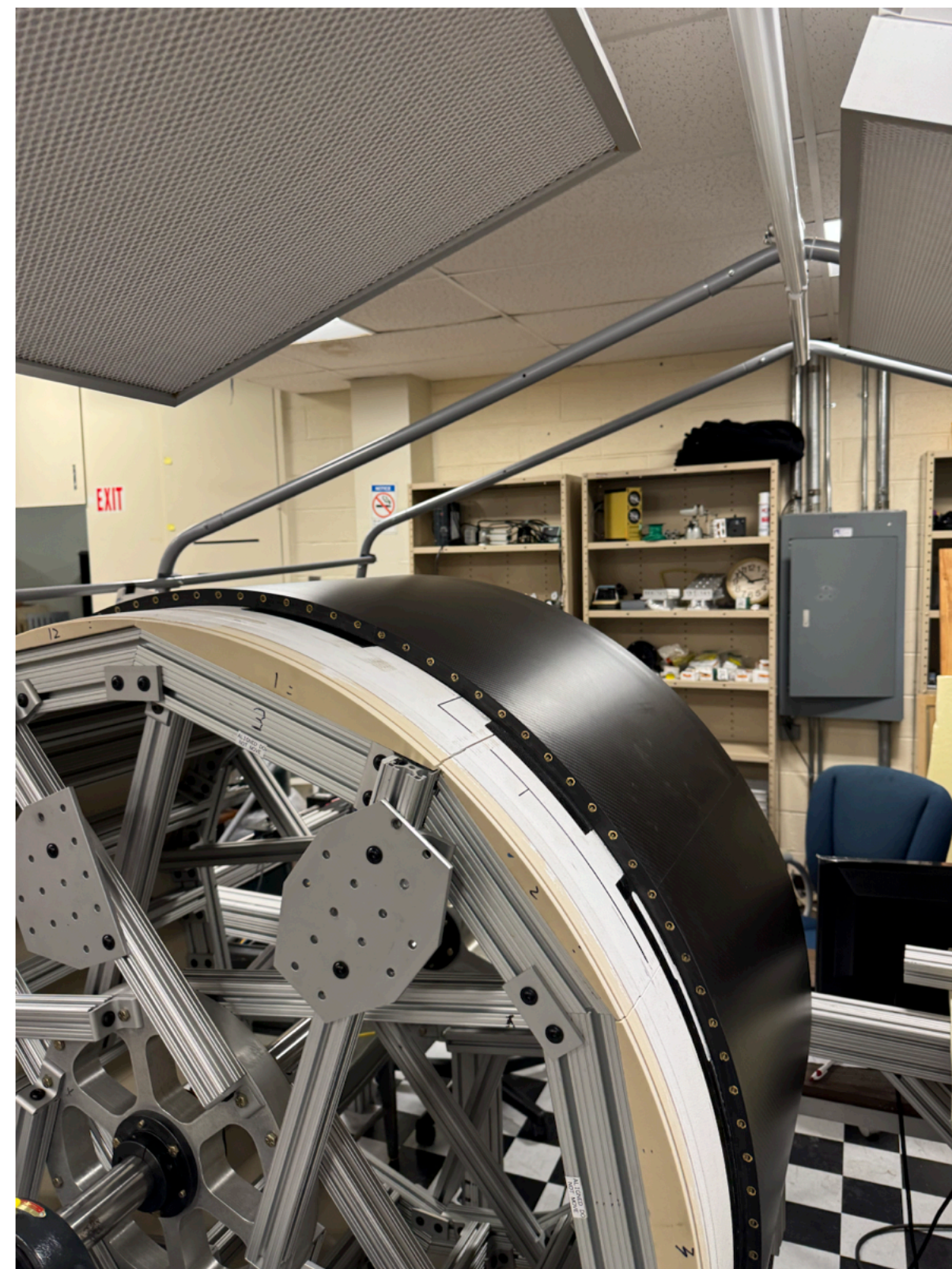

→ Precision:  $\pm 0.1$  mm

# pfRICH Vessel Assembly

Once the vessel is complete, the 80/20 frame can be collapsed to remove the foam

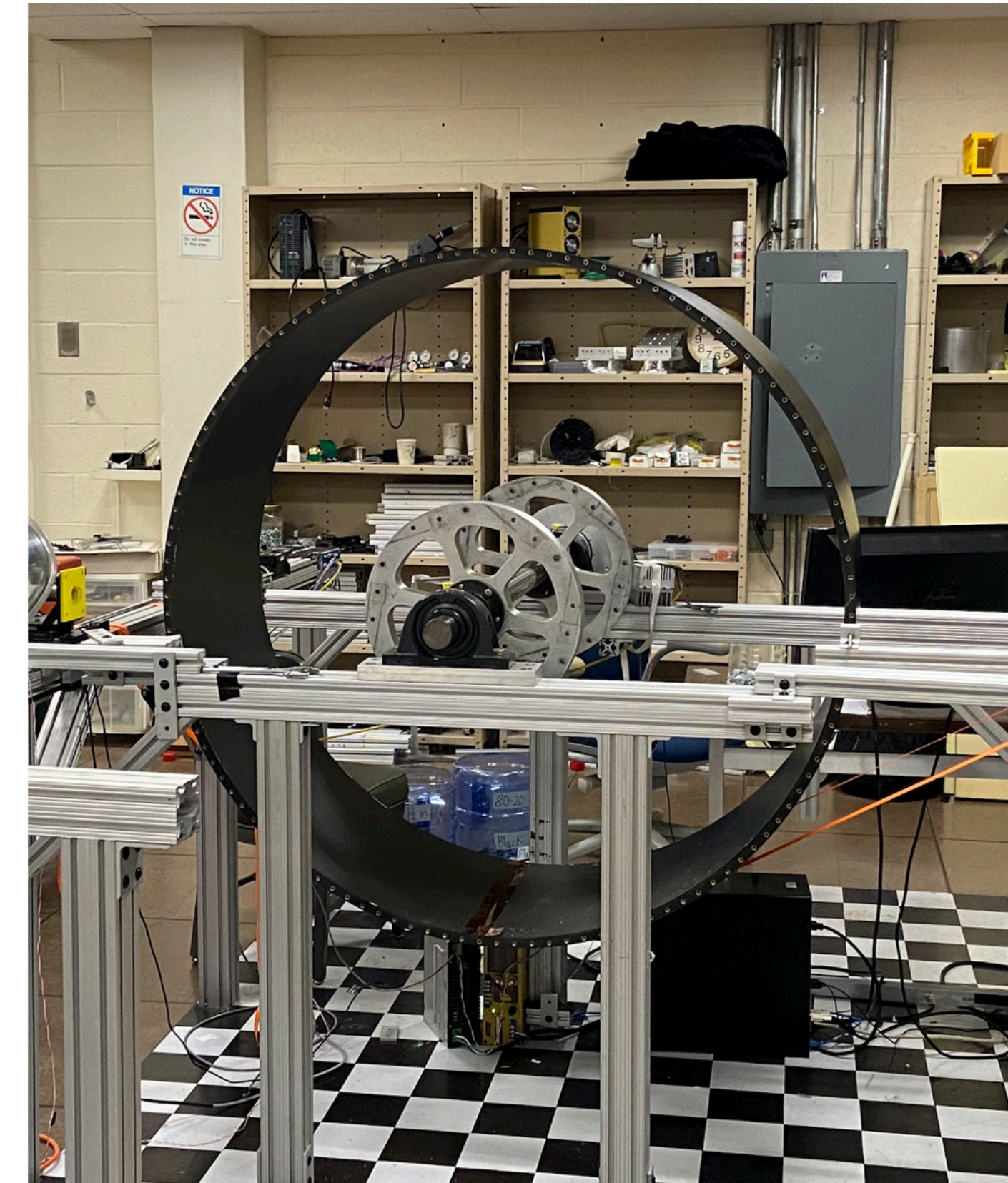
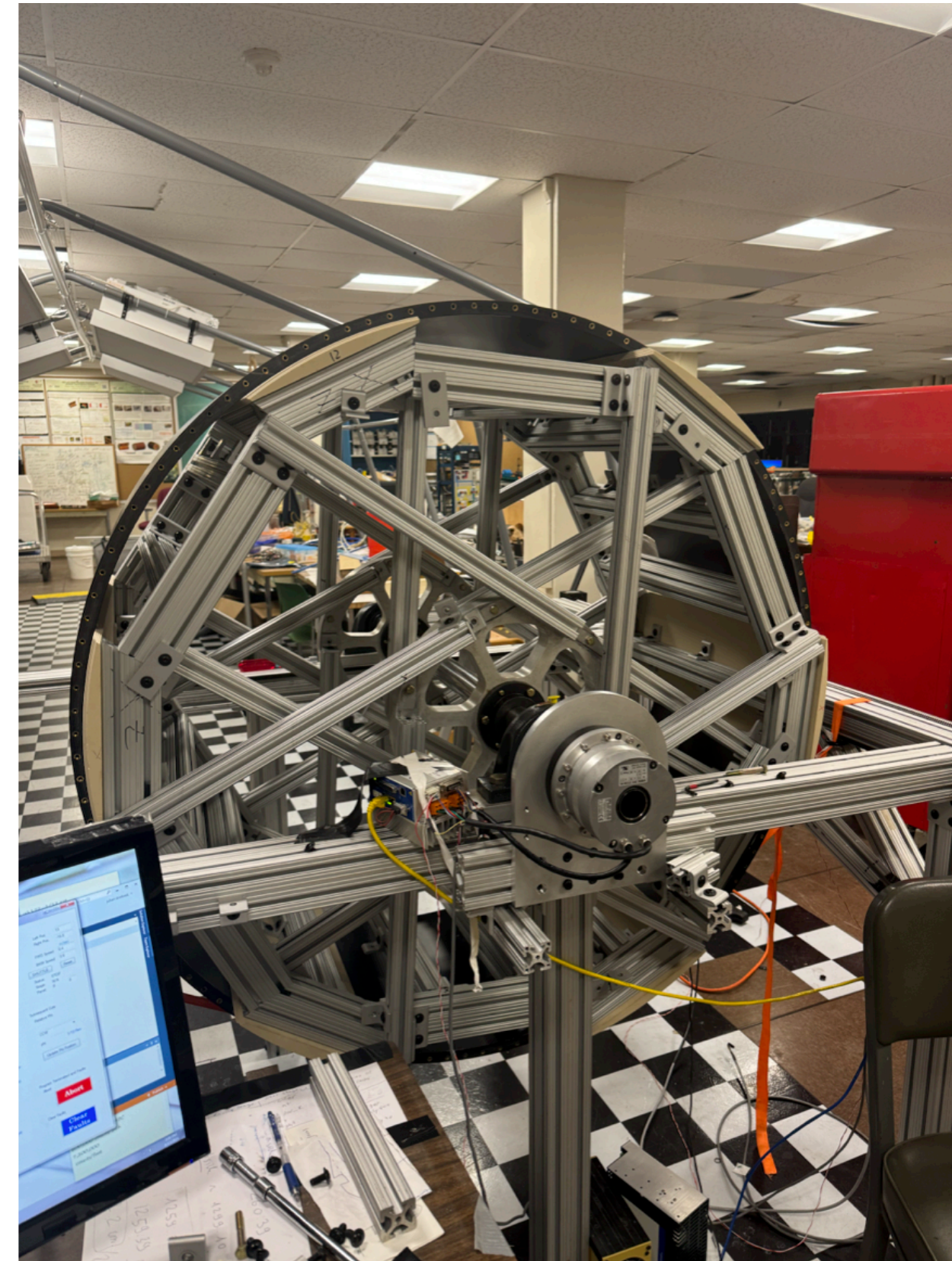

**Objective achieved! The pfRICH vessel is ready**

# pfRICH Mirror Production



- **Conical (inner/outer) and pyramidal mirrors**  
→ *enhance photon acceptance*
- **In-house fabrication**
  - Straight & curved substrates (Purdue)
  - Lexan–carbon fiber co-bonding  
→ *bonding optimization ongoing*
  - Mirror coating via evaporator setup (Stony Brook)

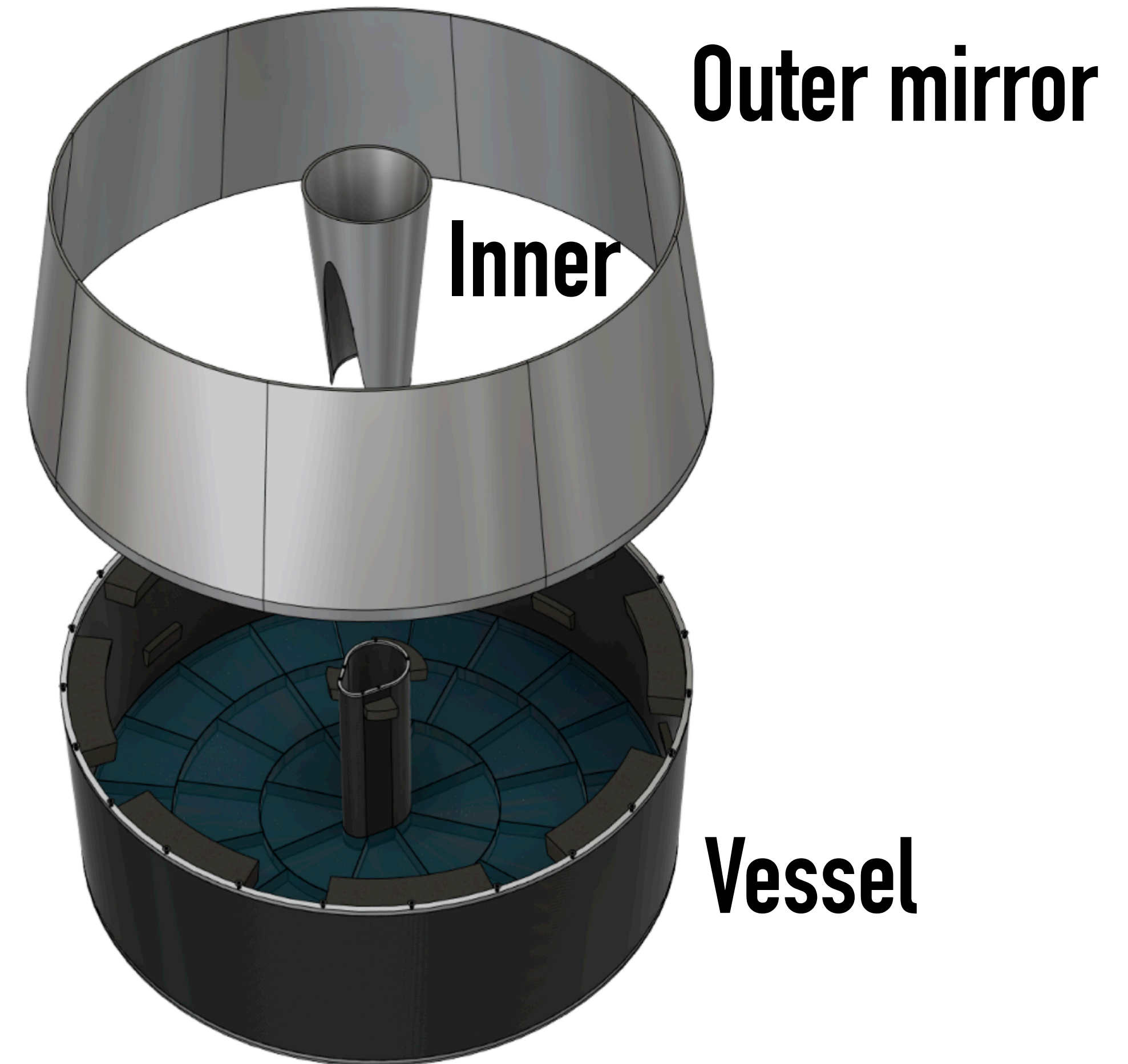

**Objective: build mirrors with high reflectivity**

# Evaporation Chamber

1. **Electron-beam heating** → source *material evaporates* (chromium, aluminum)
2. **Vacuum transport** → vapor reaches rotating *substrate* (carbon fiber-lexan)
3. **Condensation** → thin *reflective film* forms

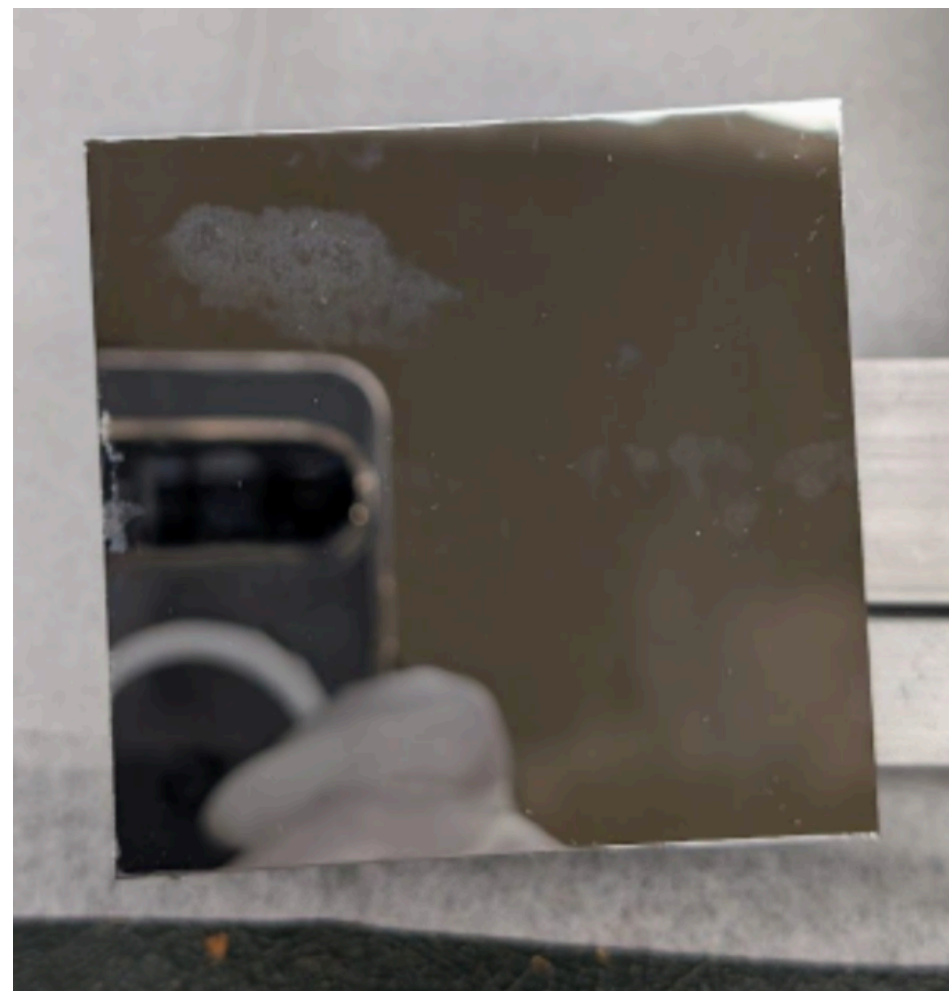

**Cr-Al coating**

**Substrate**

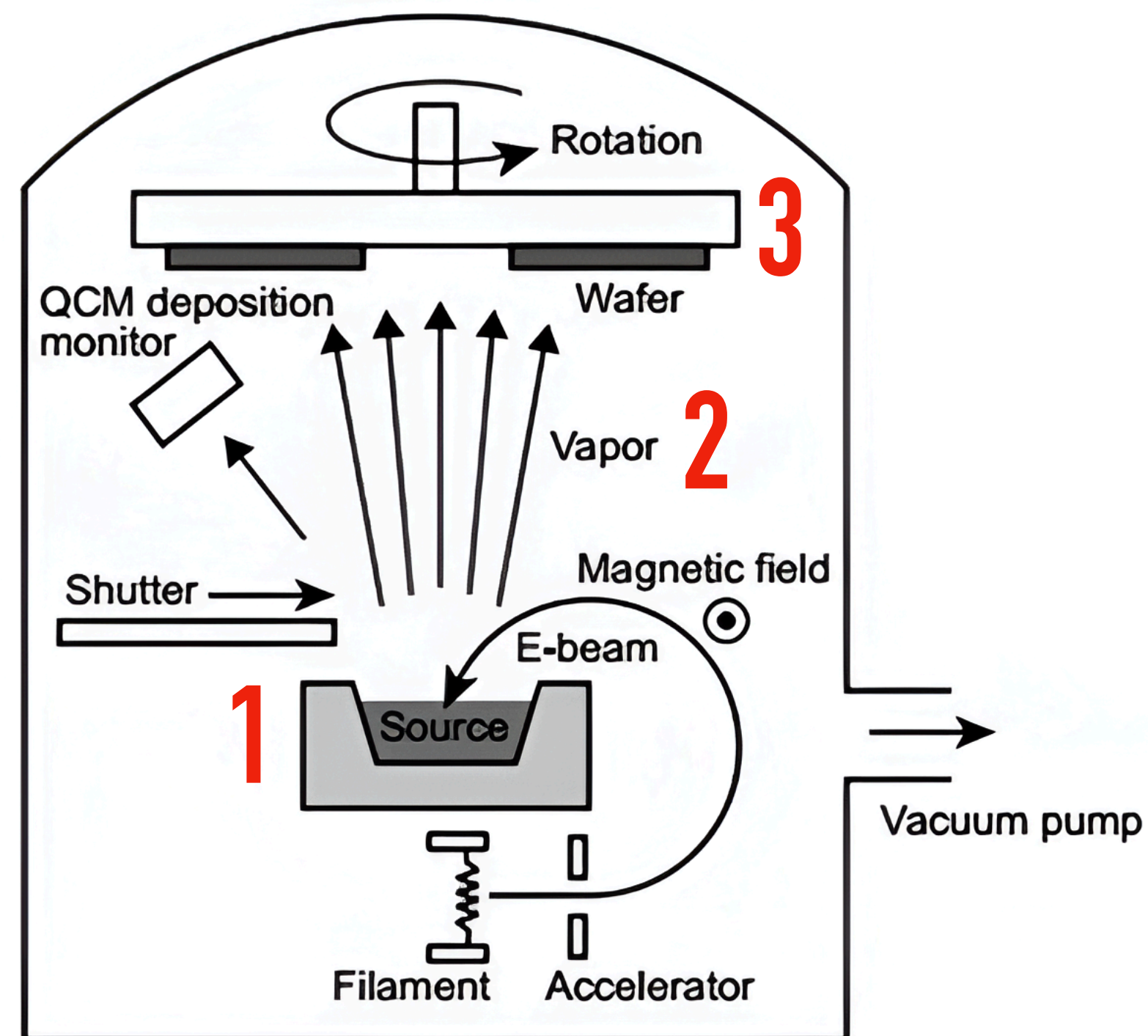

**Rotating  
Fixture for  
Substrate**

**Ion Source**

**Quartz Crystal  
Microbalance**

**Remote  
Shutter**

**Electron Gu**

# pfRICH Mirror Reflectivity

Reflectivity vs. Wavelength

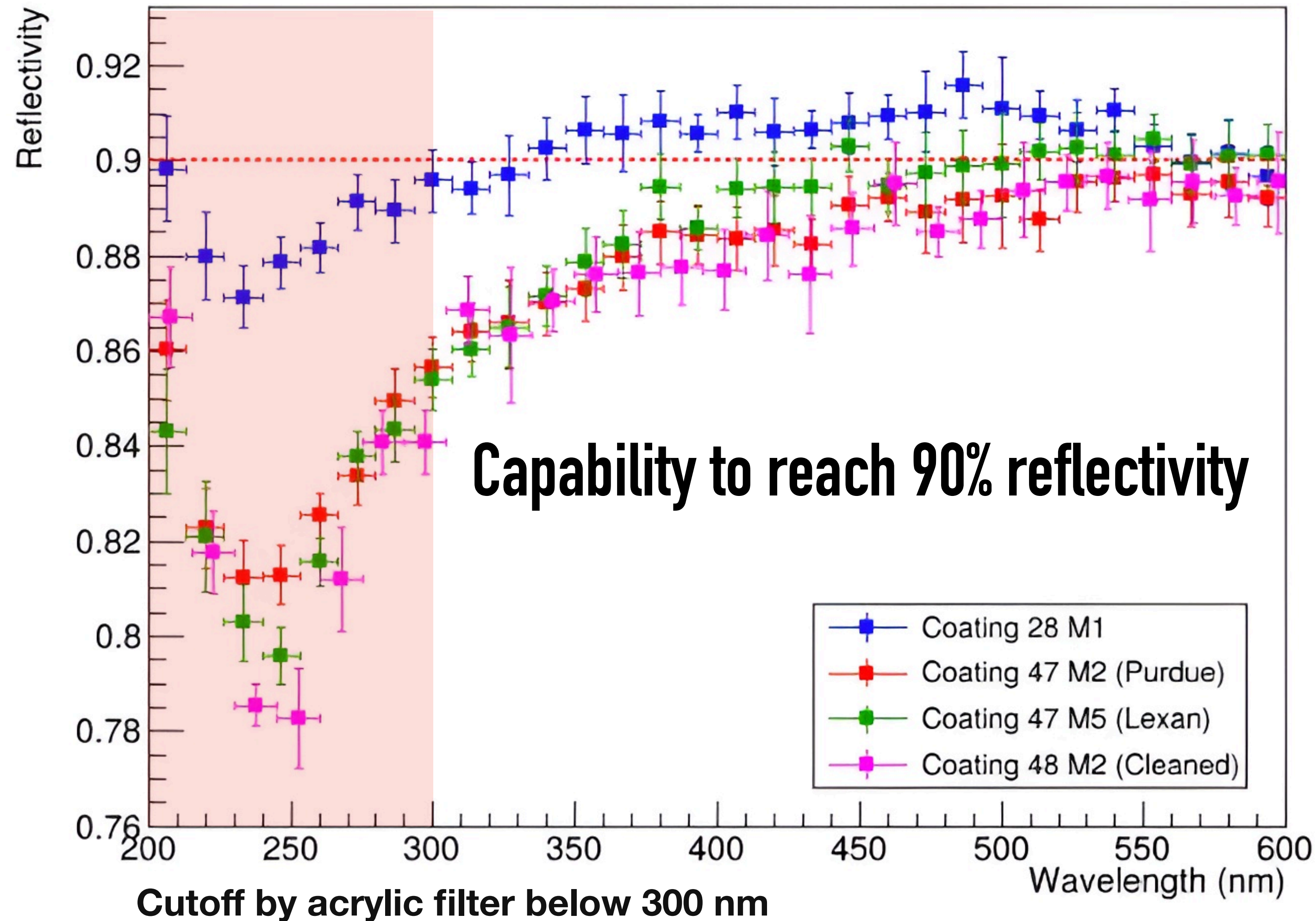

Objective: Mirrors with high reflectivity  
( $\sim 90\%$  over 300–600 nm)

## Coating mixture (sample)

- 28: Cr = 4.033 kA ; Al = 17.058 kA
- 47: Cr = 5.006 kA ; Al = 20.009 kA
- 48: Cr = 1.997 kA ; Al = 8.048 kA

**Curved mirror development**  
→ **still ongoing**

# Conclusion

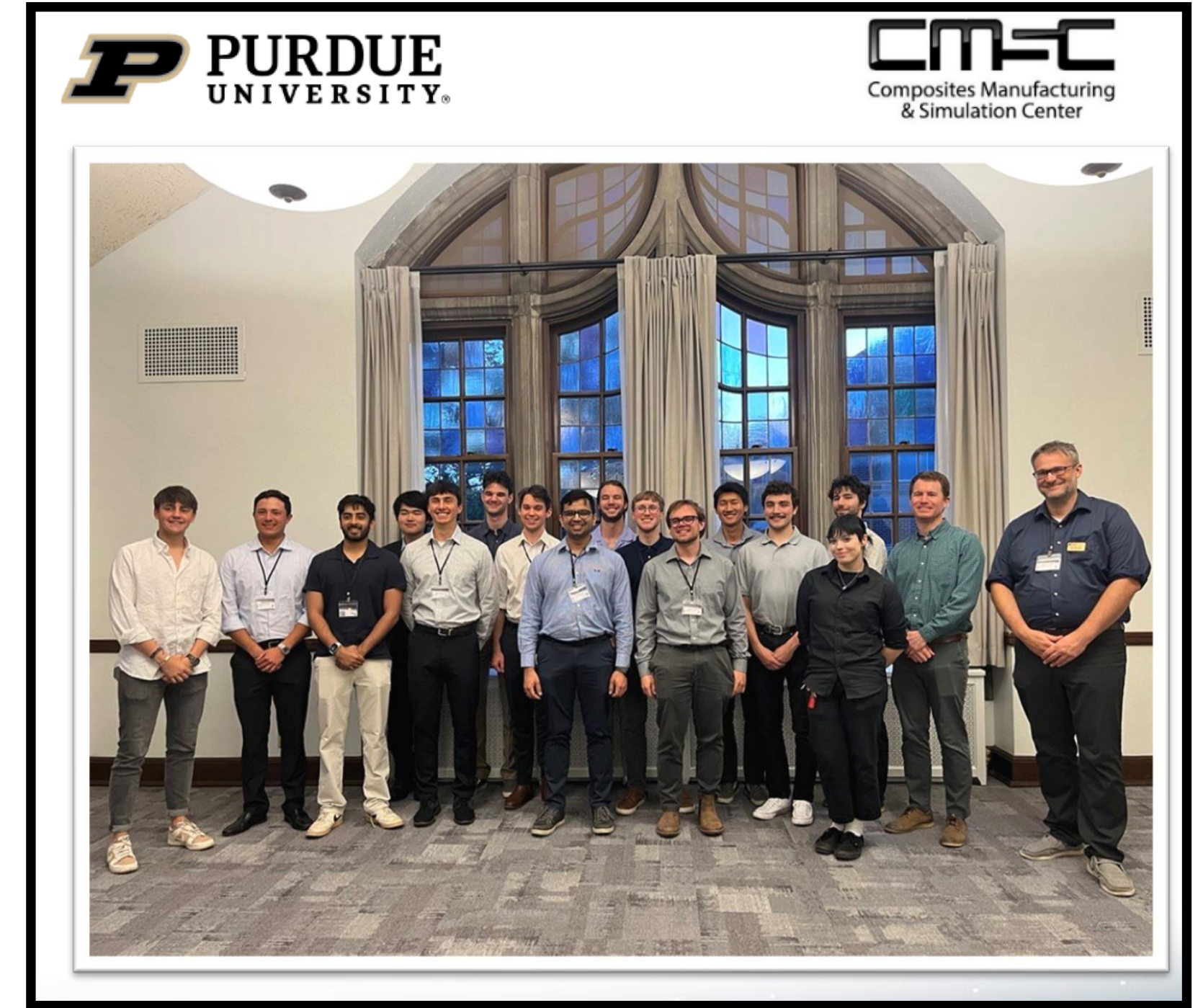
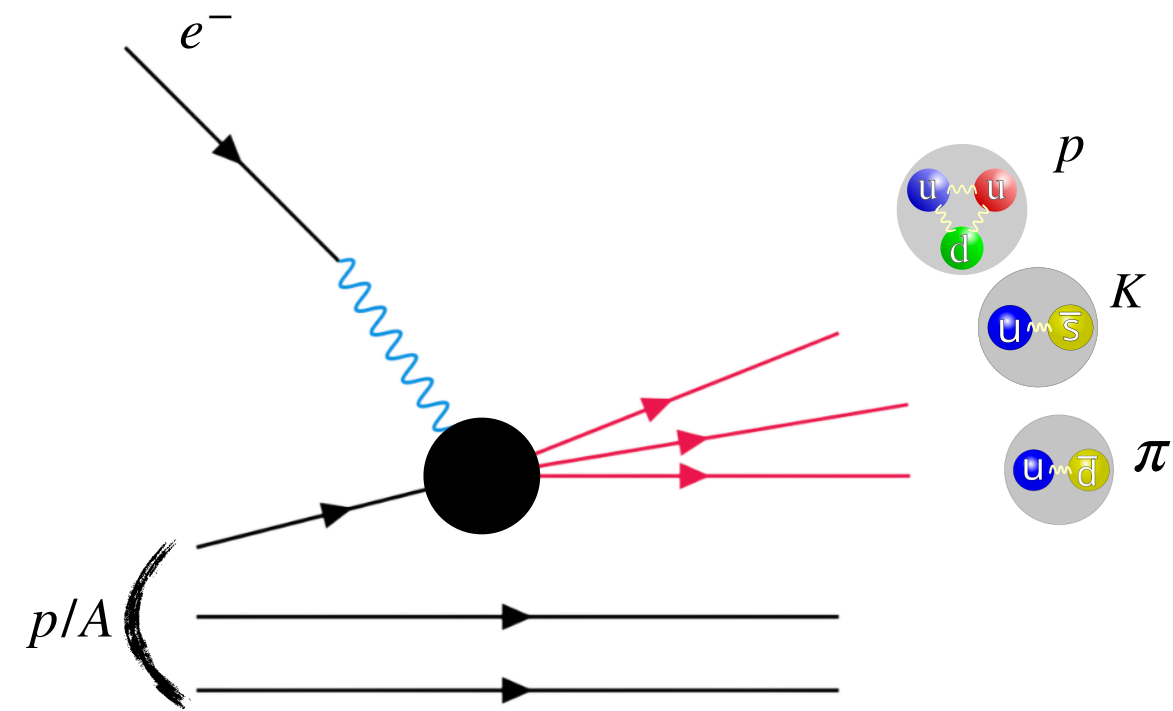

- **Hadron ID** is crucial for many EIC physics goals
  - provided in electron-going direction by **pfRICH**
- **Carbon-fiber vessel** minimizes material budget
  - **first engineering prototype completed**
- **Mirror development** with high reflectivity underway at SBU

