

Strange and Heavy Flavor Physics at EIC and ePIC status

Rongrong Ma (BNL)

03/27/2026

The 22nd International Conference on
Strangeness in Quark Matter
22-27 March, 2026, Los Angeles, CA

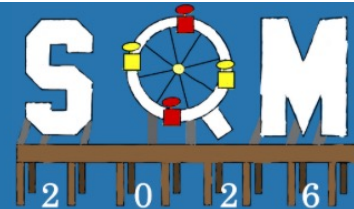

Electron-Ion Collider

- **Internal landscape of nucleons and nuclei, and underlying dynamics**
 - *How does the mass and spin of the nucleon arise?*
 - *What are the emergent properties of dense system of gluons?*
 - *How do confined hadrons emerge from quarks and gluons?*

- **How to achieve that?**
 - **High luminosity:** $L = 10^{33-34} \text{ cm}^{-2}\text{sec}^{-1}$
 - **High polarization:** $P \sim 70\%$
 - **Wide range of energy:** $\sqrt{s} = 29 - 141 \text{ GeV}$
 - With upgrade to 18 GeV electron beam
 - **Variety of ion species:** proton – Uranium

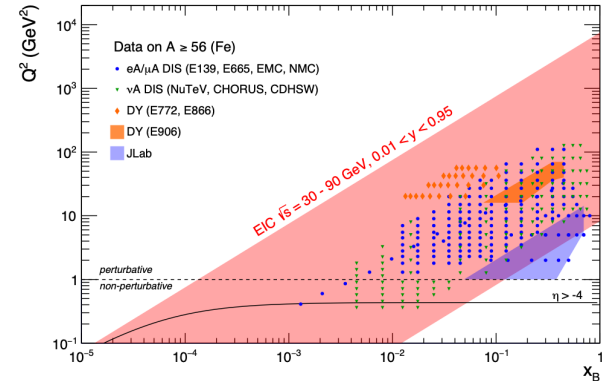

S. Diehl, et. al., arXiv:2504.01236

Electron-Ion Collider

- A single integrated line-item construction project
- Divided into **five sub-projects**
 - Accelerator Storage Rings (ASR)
 - Detector (DET) – ePIC
 - Interaction Region (IR)
 - Electron Injector (EIN)
 - Integrated Performance (IP)
- **Reuse:**
 - Ion injection and acceleration systems (Linac, Booster, AGS)
 - Polarized ion/proton sources

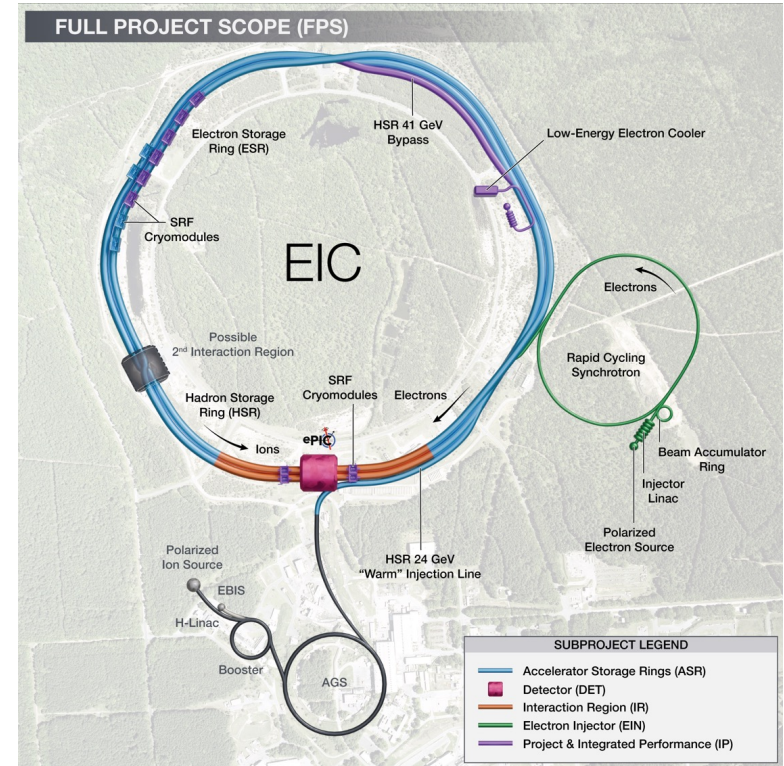

Timeline

- RHIC operation ended on 02/06/2026; removal starts on 04/01/2026
- Aim to start construction in FY27

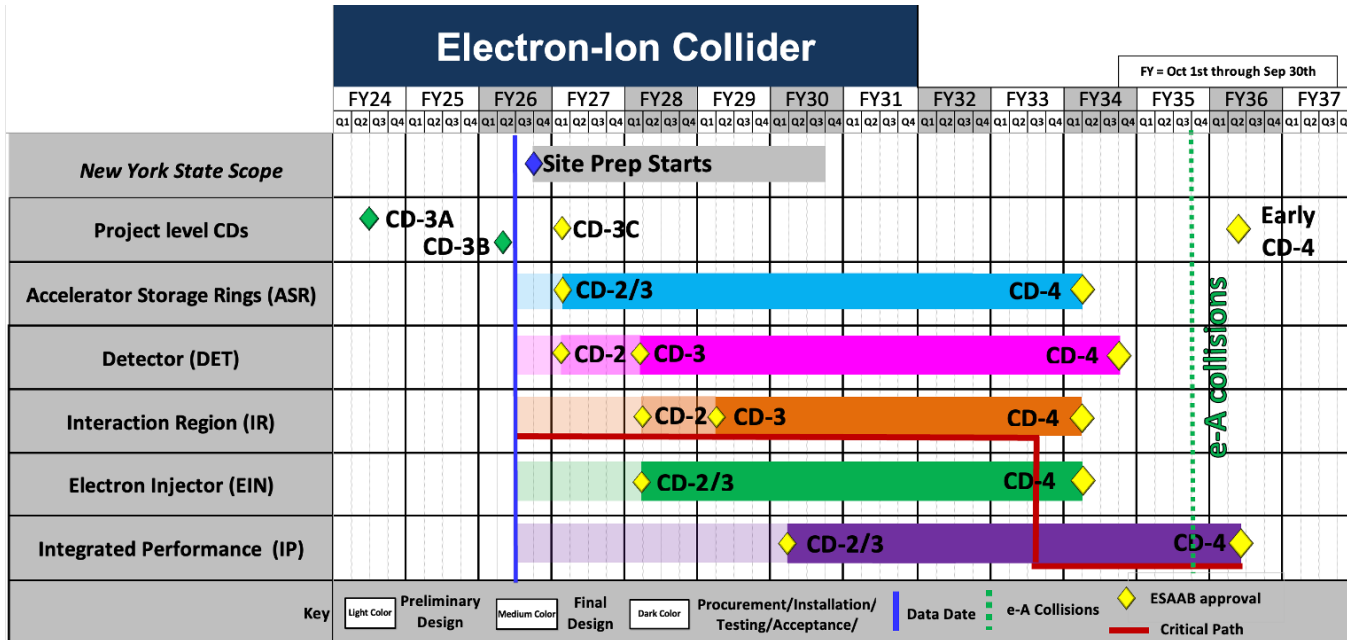

electron-Proton/Ion Collider (ePIC)

- Hadronic Calorimeters
- Solenoid Magnet
- Electromagnetic Calorimeters
- Particle Identification
- Tracking

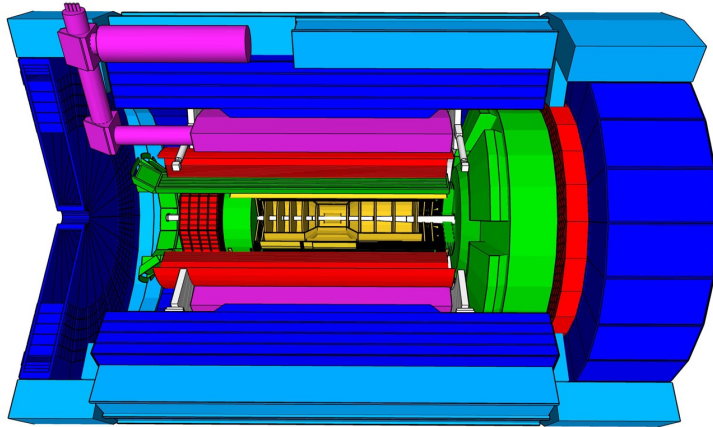

- 1.7 T superconducting solenoid
- Large acceptance ($|\eta| < 3.5$)
- Excellent tracking, calorimetry and particle identification
- Design pointing resolution

$ \eta $	$\sigma(\text{DCA}_{xy}) [\mu\text{m}]$
0 – 1.0	$20/p_T \oplus 5$
1.0 – 2.5	$30/p_T \oplus 20$
2.5 – 3.5	$30/p_T \oplus 40$

ePIC Collaboration

- Founded in July 2022
- **International:** 1100+ collaborators, 180+ institutions, 25 countries
- ePIC is a *CERN recognized experiment*

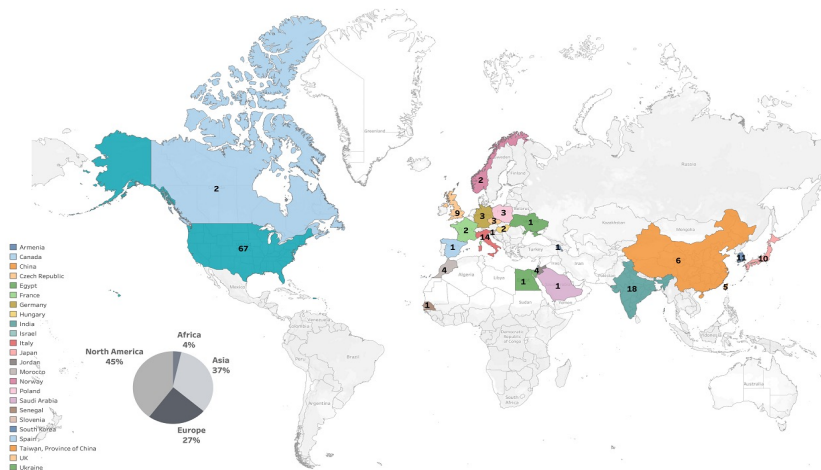

Origin of Mass: Gluon

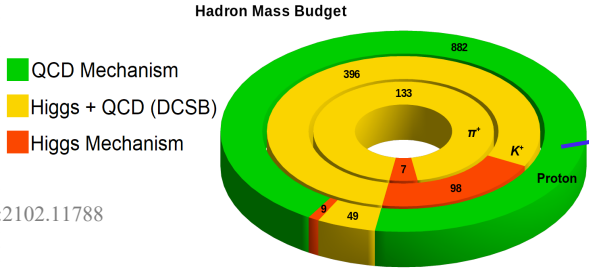

Trace anomaly

- Arise from **gluon dynamics**
- Not well understood

Credit: S. Kay
Adapted from arXiv:2102.11788

Near-threshold quarkonium production

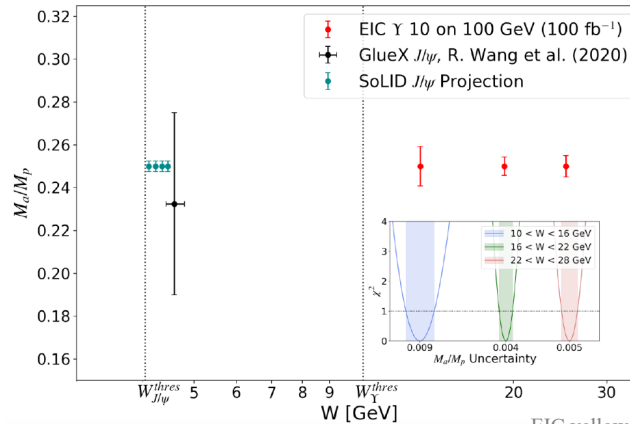
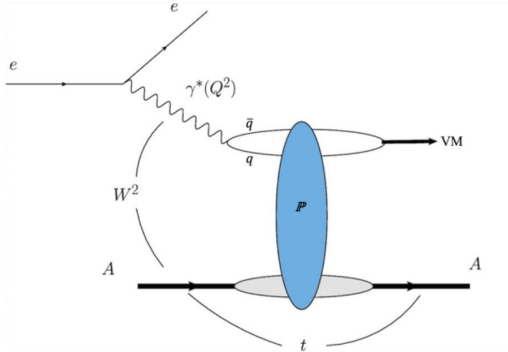

Near-threshold Υ
at EIC

EIC yellow report: arXiv:2103.05419

Origin of Mass: Quark

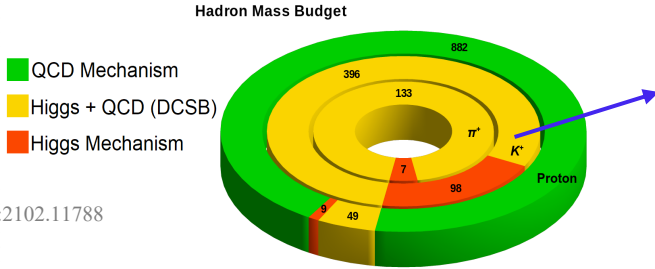

- Influence of quarks
- Kaon: contain s quark with large Higgs mass

Credit: S. Kay
Adapted from arXiv:2102.11788

Deep Exclusive Meson Production

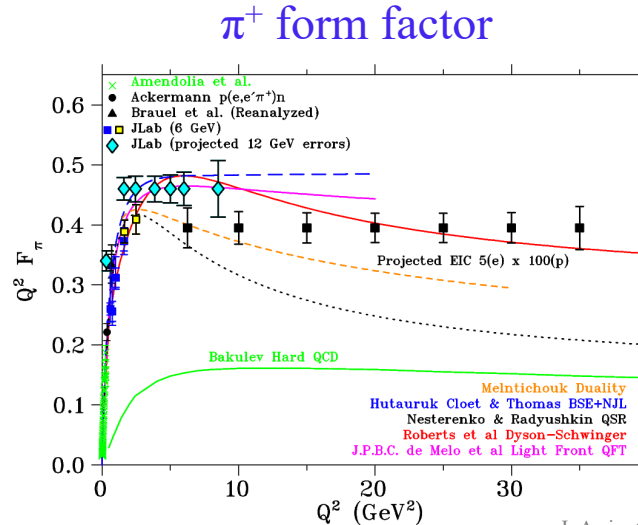
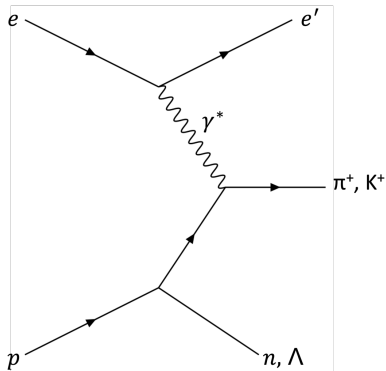

K^+ studies
underway

J. Arrington, et al., arXiv:2102.11788

Access Sea Quark with Kaon

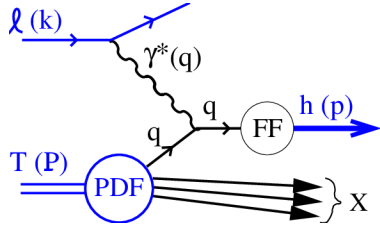

- SIDIS: extra sensitivity to parton flavor
- Kaon \rightarrow **strange quark**
- Improve knowledge in many aspects

H. Pimer, arXiv:hep-ph/0311279

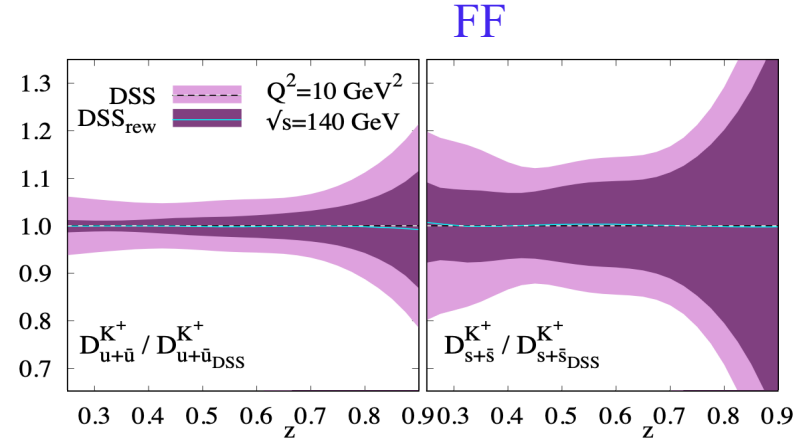
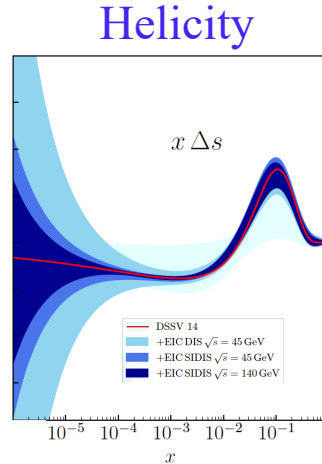
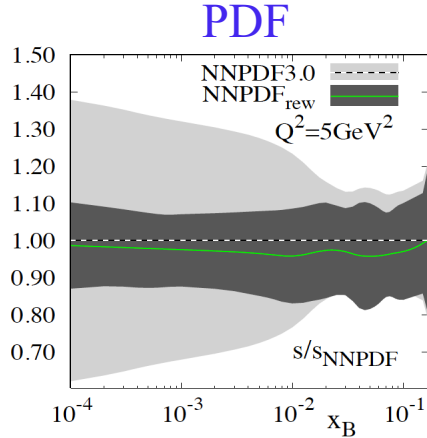

EIC yellow report: arXiv:2103.05419

Charm Quark Production

- Leading-order: photon-gluon fusion \rightarrow sensitive probe of gluons

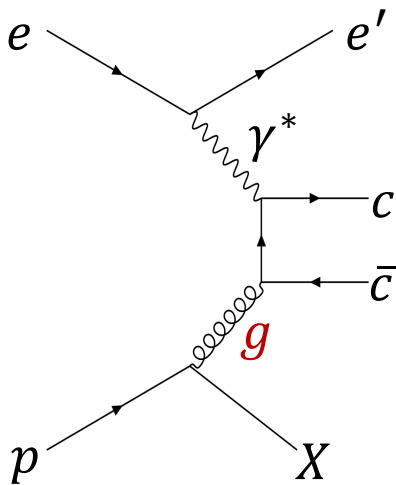

$$\sigma_r^{c\bar{c}}(x_B, Q^2) = \boxed{F_2^{c\bar{c}}(x_B, Q^2)} - \frac{y^2}{Y_+} F_L^{c\bar{c}}(x_B, Q^2)$$

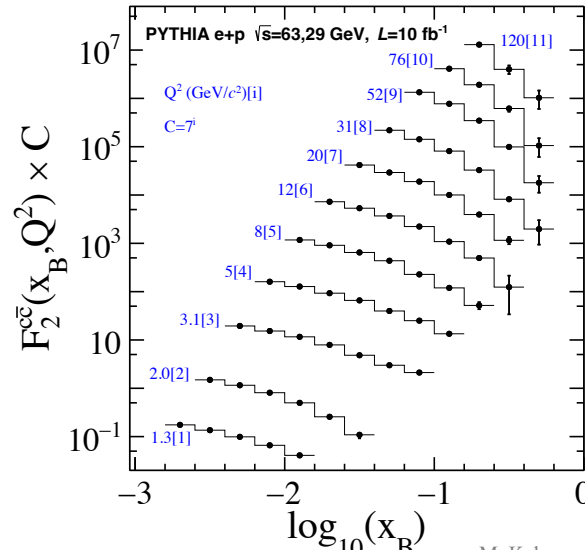

M. Kelsey, et. al., PRD 104 (2021) 054002

Access Gluon Sivers Function

- Correlation between gluon's transverse momentum with the proton spin

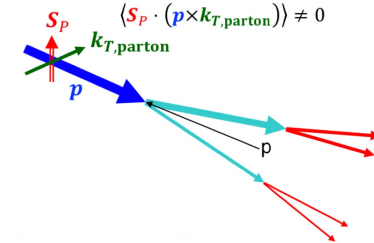

$D\bar{D}$ pair

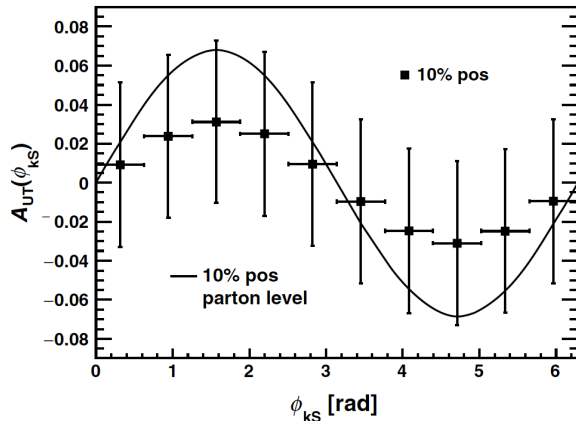

Single D

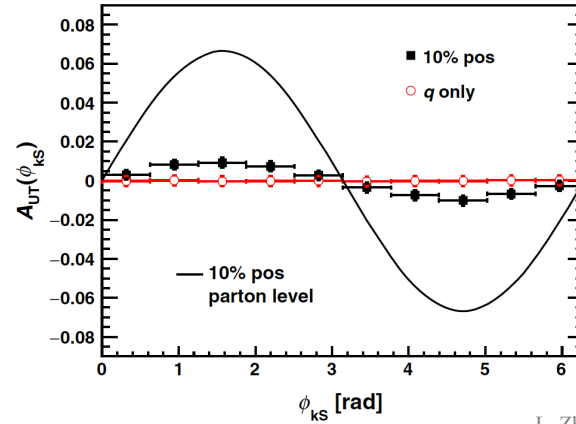

L. Zheng, et. al., PRD 98 (2018) 034011

- Complementary to other channels: di-jet, di-hadron ...

Constrain Gluon nPDF

- Compare F_2^{cc} in e+p and e+A

M. Kelsey, et. al., PRD 104 (2021) 054002

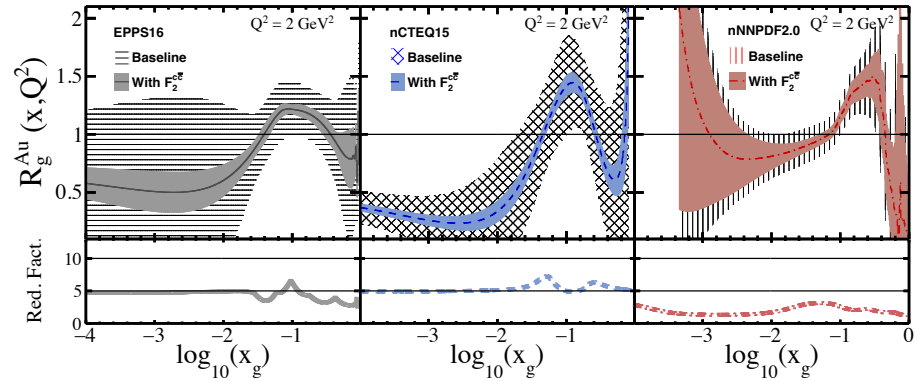
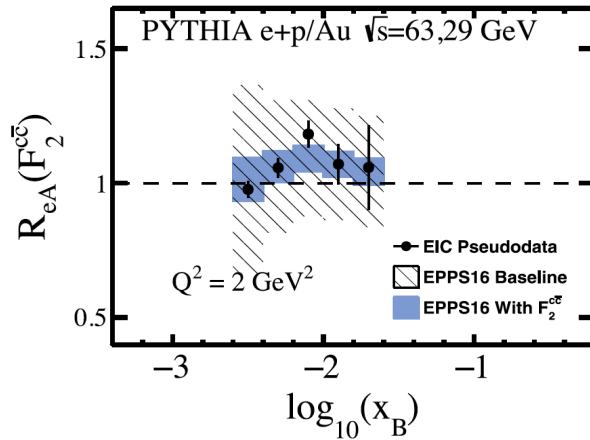

- Significant reduction of uncertainties in gluon nPDF
- Complimentary to inclusive measurements, especially *at high x*

Constrain Gluon Spatial Distribution

- Exclusive VM production

EIC white paper: arXiv:1212.1701

M. Kesler, et. al., arXiv:2502.15596

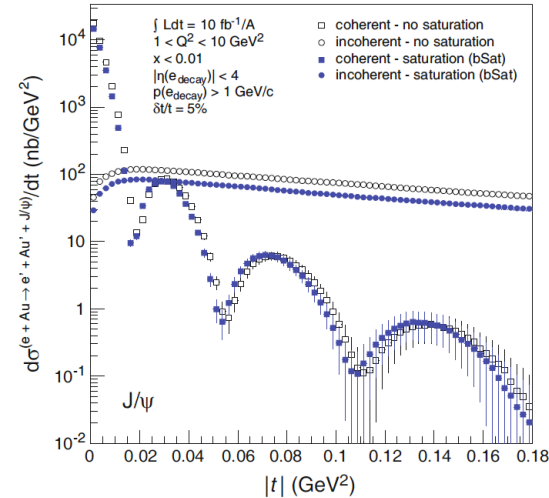
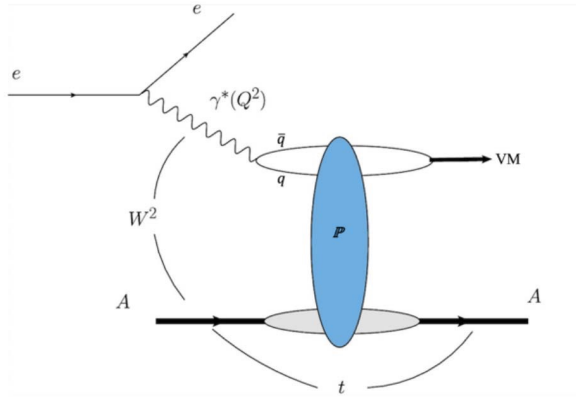

- Coherent: **diffractive pattern** \rightarrow ***b*-dependent gluon distribution**
- Incoherent: fluctuations

Charm Quark Fragmentation

- A clear difference in Λ_c/D^0 ratio has been observed in p+p and e^+e^- collisions
 - Breakdown of universality of fragmentation function?
- **How about e+p?**
 - HERA measurements are sparse with large errors
 - ePIC: **high-precision multi-differential measurements**

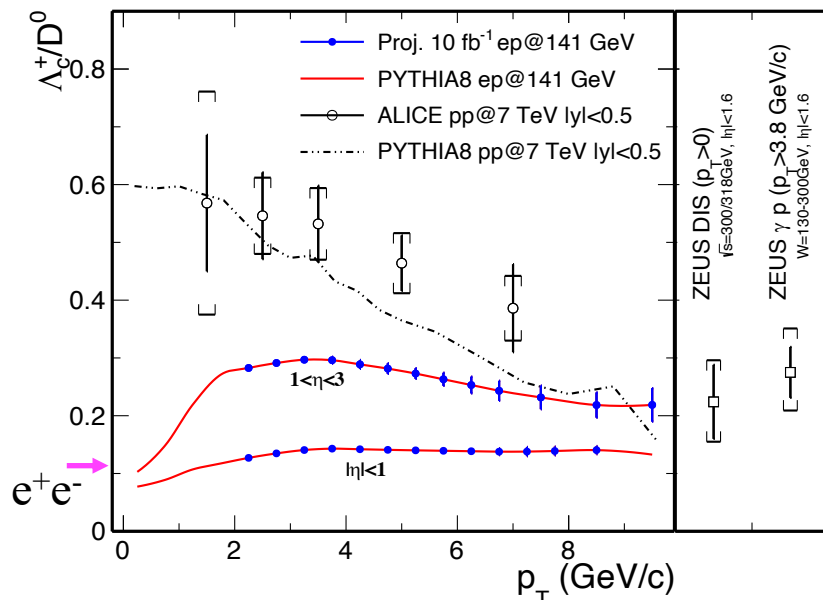

J. Arrington, et. al., arXiv:2102.08337

Propagation in Cold Nuclear Matter

- Probe hadronization and energy loss in nuclei

$$R_{eA}(p_T, z, \nu) = \frac{N^{D^0}(p_T, z, \nu)|_{eAu}}{N^{D^0}(p_T, z, \nu)|_{ep}} \times \frac{N^{inc}(\nu)|_{ep}}{N^{inc}(\nu)|_{eAu}} \rightarrow \text{Reduce initial-state effects}$$

ν : virtual photon energy

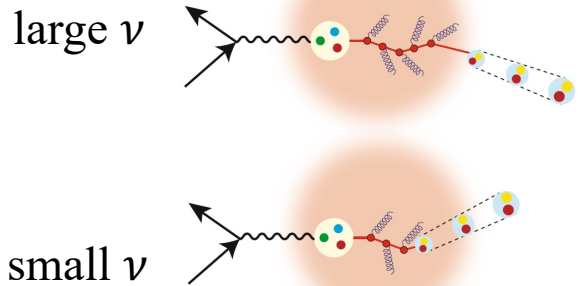

Energy loss model

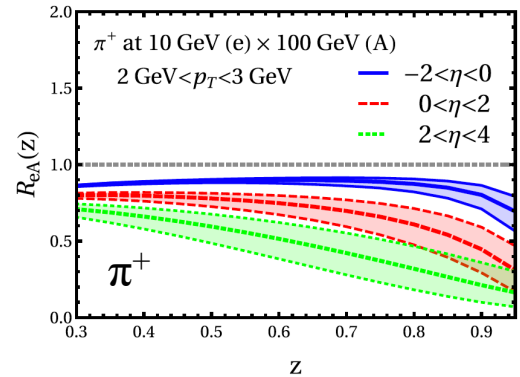
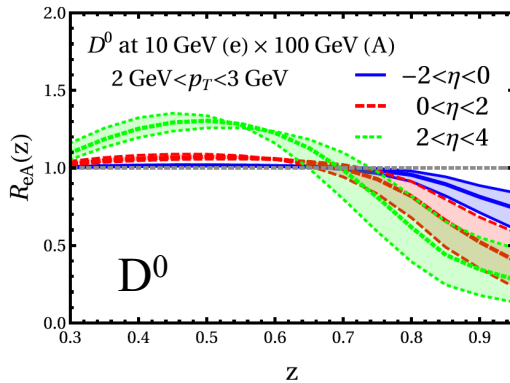

Summary

- EIC will be the **ONLY** collider in the US in the foreseeable future
 - Next milestone: CD2/3 → start of construction
 - Aim to start operation in FY35
- ePIC: state-of-the-art general-purpose detector to fully realize EIC science mission
 - **ONLY** detector currently planned
- **Strange/heavy-flavor plays an important role** in answering essential scientific questions EIC is built for